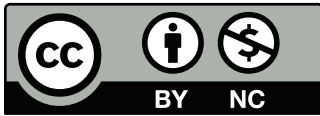

Angles

Apprenticeship and Workplace
Mathematics
(Grade 10/Literacy Foundations Level 7)

qt
inches mL°C
pounds cm³
centimetres
Ounces LITRES
FAHRENHEIT Hectares
KILOMETRES
MILES²
yd

© 2012 by Open School BC



<http://mirrors.creativecommons.org/presskit/buttons/88x31/eps/by-nc.eps>

This work is licensed under the Creative Commons Attribution-NonCommercial 4.0 International License. To view a copy of this license, visit <http://creativecommons.org/licenses/by-nc/4.0/>

Permissions beyond the scope of this license are identified in the materials by a copyright symbol and are outlined below. To request permission to use the exclusions to this Creative Commons license, contact the author/publisher of the third party materials:

Third party copyright exclusions include:

All photographs used under license from Shutterstock.com.

The Data Pages were reproduced with permission from the BC Ministry of Education.

Course History

New, March 2012

Project Partners

This course was developed in partnership with the Distributed Learning Resources Branch of Alberta Education and the following organizations:

- Black Gold Regional Schools
- Calgary Board of Education
- Edmonton Public Schools
- Peace Wapiti School Division No. 76
- Pembina Hills Regional Division No. 7
- Rocky View School Division No. 41

Project Management: Jennifer Riddel

Content Revisions: Jennifer Riddel, Ester Moreno

Edit: Leanne Baugh, Monique Brewer

Math Edit:

Learning Centre of the Greater Victoria School District Continuing Education Program:

Nigel Cocking, Keith Myles, Bill Scott

School District 47, Powell River: Tania Hobson

OSBC: Christina Teskey

Module Tests: Barb Lajeunesse, Michael Finnigan (SD 34)

Copyright: Ilona Ugro

Production Technicians: Sharon Barker, Beverly Carstensen, Dennis Evans, Brian Glover

Art Coordination: Christine Ramkeesoon

Media Coordination: Janet Bartz

Art: Cal Jones

Flash Programming: Sean Cunniam

Narration Recording: MOH Productions and Neil Osborne

Voice Talent: Felix LeBlanc, Kate Eldridge, Wendy Webb and MOH Productions

Advisors: JD Caudle (Yukon Territory), Randy Decker (SD 40), Bev Fairful (Yukon Territory), Sonya Fern (SD 62), Sandra Garfinkel (SD 39), Richard Giroday (SD 58), Sharon Hann (SD 39), Tim Huttemann (SD 20), Dan Laidlaw (SD 73), Heather Lessard (SD 53), Gloria Lowe (SD 6), Jan Malcolm (SD 36), Christina Teskey (OSBC), Jennifer Waughtal (SD 57), Ray Wong (SD 91)

Table of Contents

Section Organization	V
Angles	1
Lesson A: Sketching and Measuring Angles	3
Lesson B: Constructing Congruent Angles	29
Lesson C: Bisecting Angles	53
Lesson D: Relationships Among Angles	75
Lesson E: Parallel and Perpendicular Lines	101
Lesson F: Solving Problems Using Angles Relationships	131
Appendix	145
Data Pages	147
Activity Solutions	155
Glossary	173
Grid Paper	181

Viewing Your PDF Learning Package

This PDF Learning Package is designed to be viewed in Acrobat. If you are using the optional media resources, you should be able to link directly to the resource from the pdf viewed in Acrobat Reader. The links may not work as expected with other pdf viewers.



Download Adobe Acrobat Reader:

<http://get.adobe.com/reader/>

Section Organization

This section on Angles is made up of several lessons.

Lessons

Lessons have a combination of reading and hands-on activities to give you a chance to process the material while being an active learner. Each lesson is made up of the following parts:

Essential Questions

The essential questions included here are based on the main concepts in each lesson. These help you focus on what you will learn in the lesson.

Focus

This is a brief introduction to the lesson.

Get Started

This is a quick refresher of the key information and skills you will need to be successful in the lesson.

Activities

Throughout the lesson you will see three types of activities:

- Try This activities are hands-on, exploratory activities.
- Self-Check activities provide practice with the skills and concepts recently taught.
- Mastering Concepts activities extend and apply the skills you learned in the lesson.

You will mark these activities using the solutions at the end of each section.

Explore

Here you will explore new concepts, make predictions, and discover patterns.

Bringing Ideas Together

This is the main teaching part of the lesson. Here, you will build on the ideas from the Get Started and the Explore. You will expand your knowledge and practice your new skills.

Lesson Summary

This is a brief summary of the lesson content as well as some instructions on what to do next.

At the end of each section you will find:

Solutions

This contains all of the solutions to the Activities.

Appendix

Here you will find the Data Pages along with other extra resources that you need to complete the section. You will be directed to these as needed.

Glossary

This is a list of key terms and their definitions.

Throughout the section, you will see the following features:

Icons

Throughout the section you will see a few icons used on the left-hand side of the page. These icons are used to signal a change in activity or to bring your attention to important instructions.



AWM online resource (optional)

This indicates a resource available on the internet. If you do not have access, you may skip these sections.



Solutions

My Notes

The column on the outside edge of most pages is called “My Notes”. You can use this space to:

- write questions about things you don’t understand.
- note things that you want to look at again.
- draw pictures that help you understand the math.
- identify words that you don’t understand.
- connect what you are learning to what you already know.
- make your own notes or comments.

Materials and Resources

There is no textbook required for this course.

You will be expected to have certain tools and materials at your disposal while working on the lessons. When you begin a lesson, have a look at the list of items you will need. You can find this list on the first page of the lesson, right under the lesson title.

In general, you should have the following things handy while you work on your lessons:

- a scientific calculator
- a ruler
- a geometry set
- Data Pages (found in the Appendix)

Angles

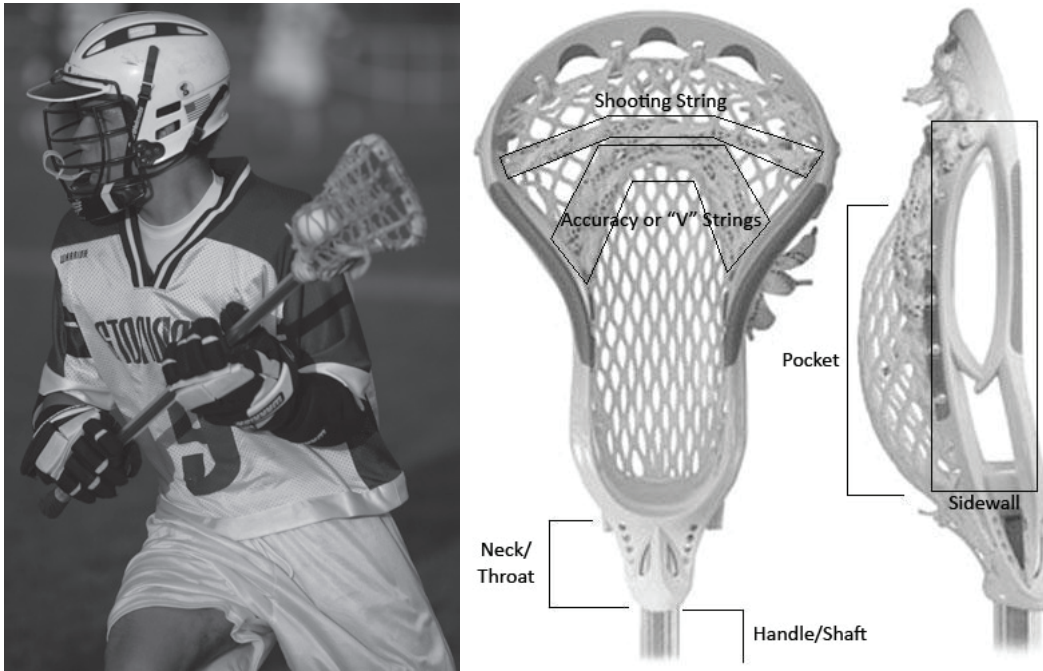


Photo by Larry St. Pierre © 2010

The game of lacrosse originated among the First Peoples of North America and has been an important part of their culture for almost a thousand years. Recognized by an act of Parliament in 1994 as Canada’s national summer sport, it is a vigorous game enjoyed by young men and women across our country!

The graphic is of a contemporary lacrosse stick. The webbing geometric design changes from the pocket to the shooting string to make it easier to either cradle or shoot the ball. The parallel lines, four-sided figures, and the repeated angles in the webbing illustrate that geometry plays an important role in sports equipment.

In this section you will explore the geometry of angles. In particular, you will investigate how they are defined, measured, classified, duplicated, and bisected. As well, you will explore relationships among the angles formed when two parallel lines are cut by a third line. In each case, you will apply definitions and relationships to solve a variety of practical problems.

ANGLES

In this section you will:

- classify angles and pairs of angles.
- draw, bisect, replicate, and construct a variety of angles.
- solve problems that involve parallel, perpendicular and transversal lines, and the pairs of angles formed between them.

Lesson A

Sketching and Measuring Angles

To complete this lesson, you will need:

- a protractor
- a ruler
- scissors
- a compass
- several blank sheets of paper

In this lesson, you will complete:

- 5 activities

Essential Questions

- How can you sketch and describe angles of various measures?
- How are referents used to estimate the measure of a given angle?
- How is the protractor used to measure angles in a variety of orientations?

My Notes

Focus



Photo by Vitaly M © 2010

Cue sports such as snooker require a steady hand, practice, and an eye for angles. What separates the novice and the skilled player is the ability to predict how the billiard balls will behave when struck and when they carom off the cushions. Spaced at regular intervals along the table's perimeter are diamond shapes, which assist a player in assessing possible angles to line up the shot. When a cue ball strikes another, what is the largest possible angle the ball struck can be deflected from the line along which the cue ball was travelling?

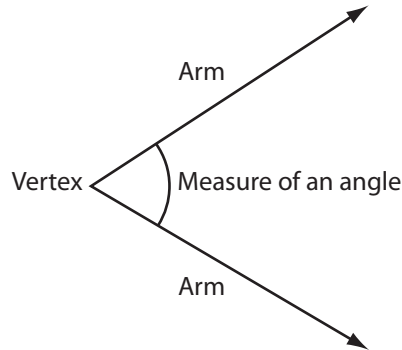
Get Started

To move through this lesson and further through the section you will need to be able to measure and draw angles. In this part of the lesson you will review the parts of an angle and how to sketch and measure angles using a protractor.

Parts of an Angle

In previous math courses you drew and measured **angles** of various sizes.

An angle is a geometric shape formed by two rays with a common endpoint. Each ray is called an *arm of the angle*. The common endpoint of the arms of the angle is the vertex of the angle.



The measure of an angle is commonly given in degrees. There are 360 degrees (360°) in one rotation.



To see all the angles possible in one 360 degree rotation, go and look at *Angle Definition* (<http://media.openschool.bc.ca/osbcmmedia/math/mathawm10/glossary/Division03/Angle/index.html>).

Did You Know?

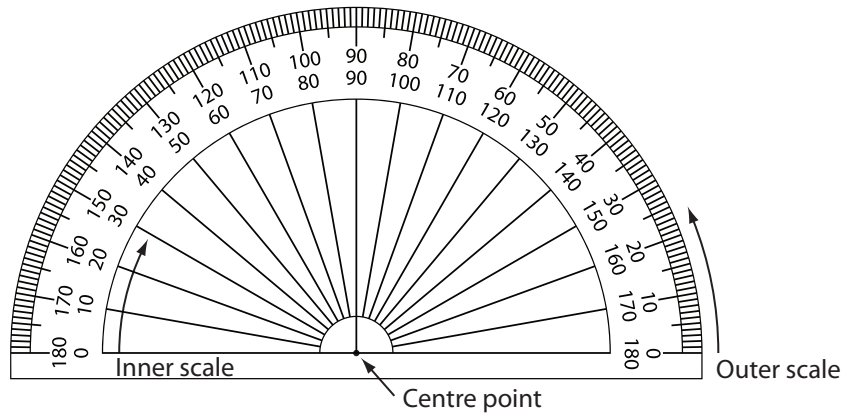
In ancient times, the peoples of the Middle East and India divided the circle into 360 parts. This was partly because there are approximately 360 days in a year and the stars move in the sky in a great circle that takes a year to complete. They didn't use 365 because the number 360 is much more convenient to use. Besides 1 and 360, the number 360 can be divided evenly by 2, 3, 4, 5, 6, 8, 9, 10, 12, 15, 18, 20, 24, 30, 36, 40, 45, 60, 72, 90, 120, and 180. Arithmetic is simpler using 360 than it is using 365!



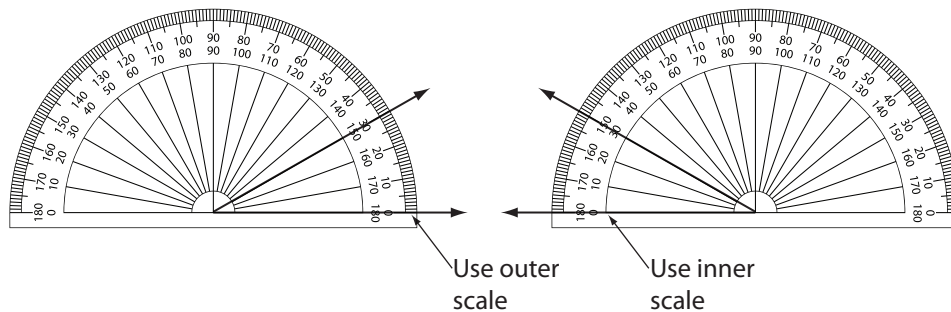
My Notes

Measuring and Drawing Angles

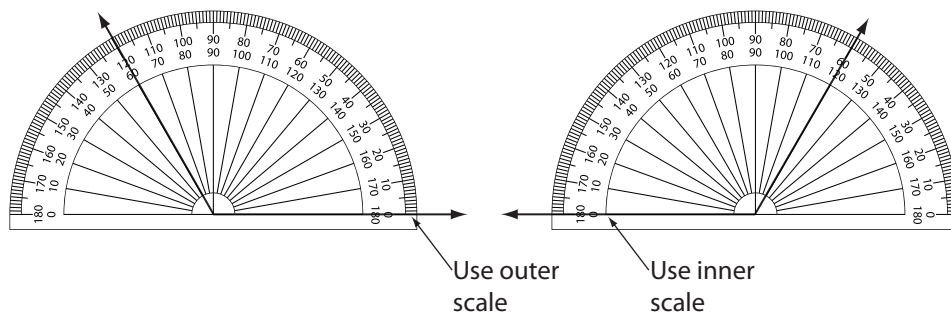
First review how to use your protractor.



The two scales on your protractor are used to measure angles drawn in different orientations. Remember, line up the centre-point of the protractor with the angle's vertex. Then start at zero on one of the protractor's scales. Both of the angles pictured below measure 30° .



Obtuse angles can be measured the same way. Both of the angles pictured below measure 120° .



Go an look at *Protractor* (<http://media.openschool.bc.ca/osbcmmedia/math/mathawm10/glossary/Division03/Protractor/index.html>). Use the demonstration applet to practise measuring angles. Watch the angle measurements changing as you drag the coloured dot.

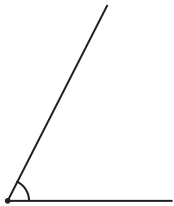
Activity 1 Self-Check

My Notes

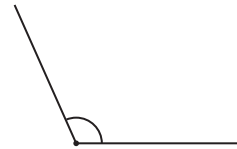
To complete this activity, you'll need your protractor and straightedge.

- Use a protractor to measure each angle. Record all measurements to the nearest degree.

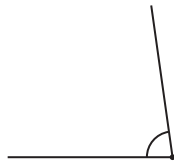
a.



b.



c.



d.



- Draw each angle from the measurements below. Draw the angles in parts a and b opening to the right as in 1. a and b. Draw the angles in parts c and d opening to the left as in 1. c and d.

a. 49°

My Notes

b. 149°

c. 16°

d. 127°



Turn to the solutions at the end of the section and mark your work.

Explore

My Notes

You may have used **referents** in math to estimate length and area in SI and in imperial units. Now, we will examine referent angles.

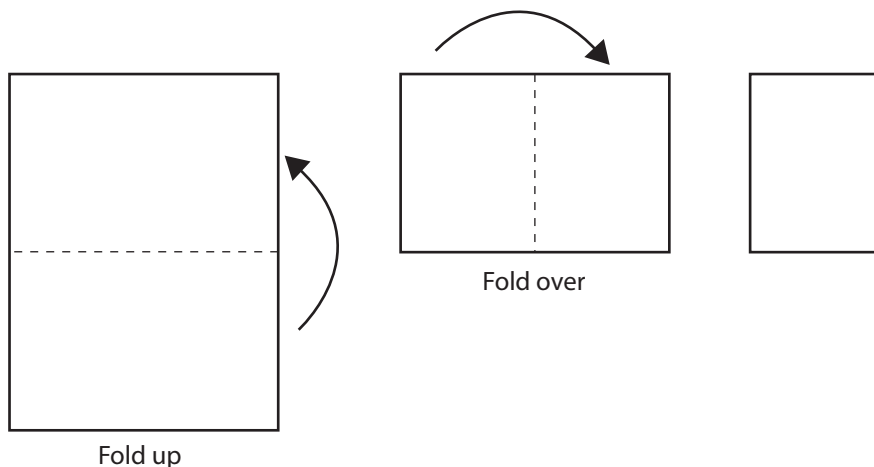
Referent angles can help you estimate the sizes of angles you encounter. If you know approximately how big a few referent angles are, you can compare their measures with the angle you must estimate.

In the next activity you will create several referent angles through a paper-folding exercise.

Activity 2 Try This

In this activity you develop referents for estimating the measure of an angle from 0° to 180° . You will need a blank sheet of paper, scissors, a protractor, and compasses to complete this activity.

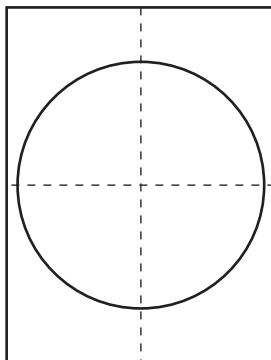
Step 1: Fold a blank sheet of paper in half from top to bottom. Then fold it in half again, this time from side to side.



Step 2: Unfold the sheet of paper and use your straightedge to draw lines along the creases.

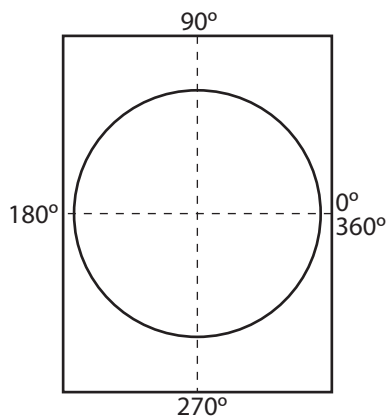
My Notes

Step 3: Draw a circle with a radius of at least 8 cm. The centre of the circle is the point at the centre of the page where the lines cross.



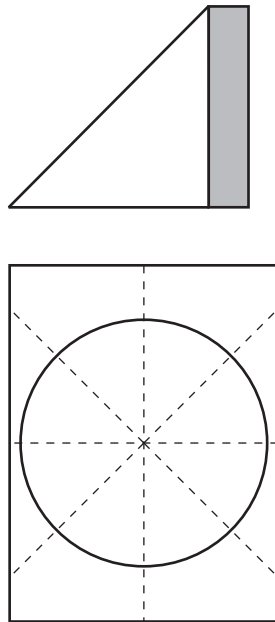
1. With your protractor, measure the angle between the two lines. Why must this angle measure 90° ?

Step 4: Write the measures of the angles as you go once around the circle as shown.



My Notes

Step 5: Fold the paper along the folds you created in Step 1. Then fold it at the centre to form a triangle. The folded edges shown at the bottom of the diagram must match. Then cut off the excess paper on the right (shaded in the diagram below) so that when you unfold the paper it is a square, as shown. Use your straightedge to draw lines along the new creases.



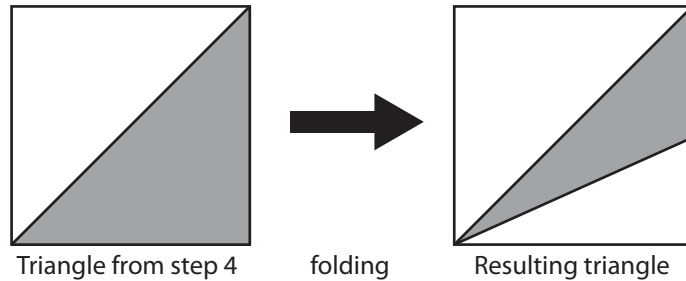
- Without using a protractor, how large is each of the 8 angles? Explain how you know this is true.

Step 6: Write the measures on each of the new angles as you did in Step 4.

My Notes

Step 7: Fold your paper back into the triangle of Step 5.

Now, fold the triangle from Step 5 in half, as shown below, to form a smaller triangle.



Now, unfold the paper. You should have 16 small angles formed around the centre of the paper.

- How large is each of the 16 small angles? How do you know this is true?

Step 8: Write the measures on the new angles as you did in Steps 4 and 6.



Turn to the solutions at the end of the section and mark your work.

Referent Angles

You have divided your circle into quarters, eighths, and sixteenths. You have created angles that measure 22.5° , 45° , and 90° . You have also created angles that are multiples of these measures. You can use the angles you created as benchmarks, or referents, to help you estimate the size of a given angle.

These are not the only useful referents. It is also helpful to know the sizes of 30-degree and 60-degree angles to use as referents. These two angles will help you refine your estimates. In the next activity you will create 30-degree and 60-degree angles.

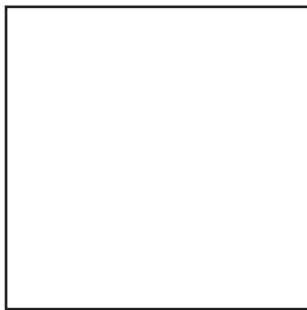
Activity 3 Try This

My Notes

To complete this activity, you will need a square sheet of blank paper, scissors, a protractor, and compasses.

Step 1: You are going to fold your square piece of paper as shown in the diagram below.

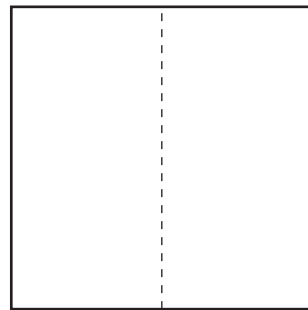
Fold the square sheet of paper in half. Unfold the sheet. Then, fold the right half in toward the centre crease. Now, unfold the sheet to reveal the two creases.



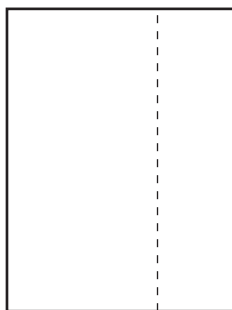
Original sheet



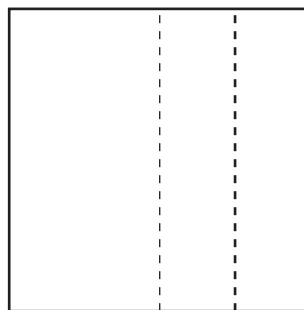
Folded in half



Unfolded showing crease



Right half folded inward

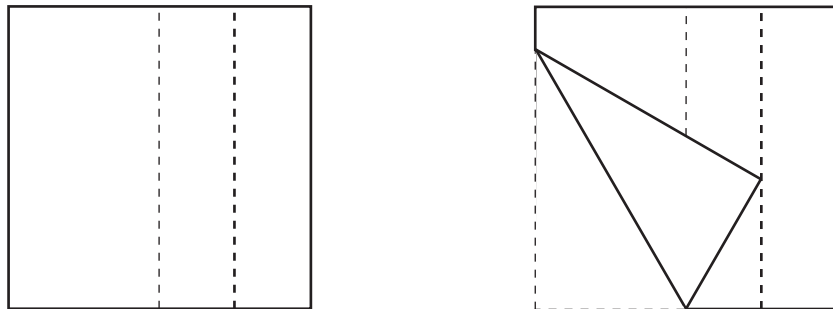


Unfolded showing both creases (dashed)

My Notes

1. What fraction of the entire sheet is each narrow vertical strip?
How do you know this is true?

Step 2: Take the bottom left corner and place it on the right quarter line as shown in the diagram below. Holding the corner on that line, crease the paper so that the crease passes through the bottom endpoint of the centre line. Cut out the triangle (shown in bold below).



2. Using your protractor, measure each angle of the triangle. How large is each angle?

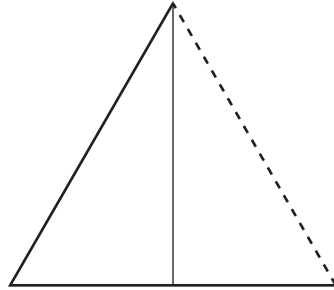
Step 3: On each angle of the triangle, write its measure. Cut out the triangle and keep it to use as a referent.



Turn to the solutions at the end of the section and mark your work.

More Referent Angles

In Activity 3, you created two new referent angles: 30° and 60° . To explain why these angles are these measures, let's think about a special type of triangle. An *equilateral triangle* is a triangle that has sides of equal lengths. Equilateral triangles also have three angles of equal measure. When you folded the square page, you created an equilateral triangle.

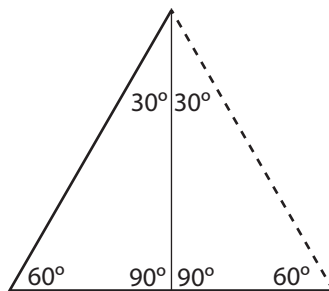


In any triangle the sum of the angles is 180° .

$$180^\circ \div 3 = 60^\circ$$

So each of the three equal angles must be 60° .

It follows that, if you split the triangle in half, the angles will be as shown below. These are the angles you measured in the activity.



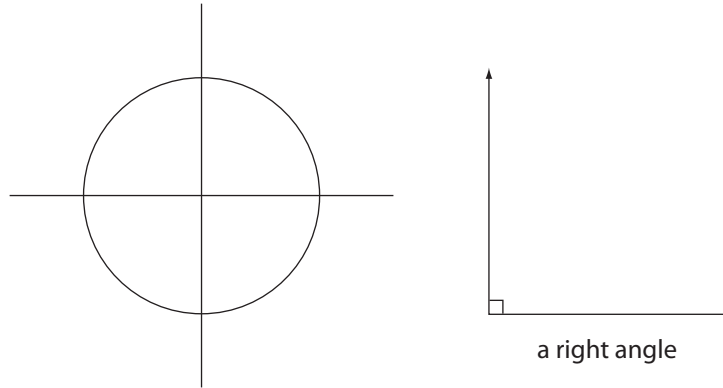
Bringing Ideas Together

In Getting Started and Explore, you reviewed the parts of angles, how they are measured, and what referents may be used to estimate their size. Before developing your estimation skills further, you will investigate how angles are classified by their sizes.

My Notes

Right Angles


In Explore you began by folding a sheet of paper to divide one complete rotation into quarters. Each of the four angles was $\frac{1}{4} \times 360^\circ = 90^\circ$ in measure. A 90-degree angle is called a **right angle**.



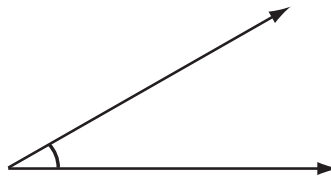

Most home designs involve countless right angles. Wall and floors meet at right angles—corners are square. A small square is often drawn between the arms of a right angle.

Acute Angles

Did You Know?
 The word *acute* means *sharp*.



An acute angle is an angle that measures less than 90° .

To investigate acute angles, go and look at *Acute Angles* (<http://media.openschool.bc.ca/osbcmmedia/math/mathawm10/glossary/Division03/Acute%20Angle/index.html>).

My Notes

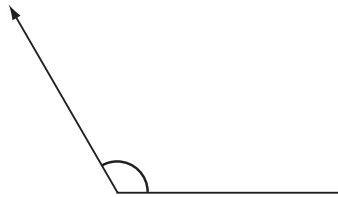
Obtuse Angles

Did You Know?

The word *obtuse* means *dull*.



An obtuse angle is an angle with a measure greater than 90° but less than 180° .



To investigate obtuse angles, go and look at *Obtuse Angles* (<http://media.openschool.bc.ca/osbcmmedia/math/mathawm10/glossary/Division03/Obtuse%20Angle/index.html>).

Straight Angles

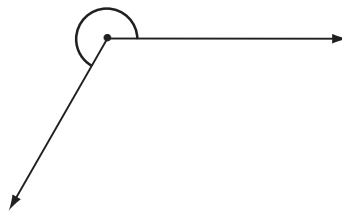
A straight angle measures exactly 180° .



To investigate straight angles, go and look at *Straight Angles* (<http://media.openschool.bc.ca/osbcmmedia/math/mathawm10/glossary/Division03/Straight%20Angle/index.html>).

Reflex Angles

A reflex angle is an angle with a measure greater than 180° but less than 360° .



To investigate reflex angles, go and look at *Reflex Angles* (<http://media.openschool.bc.ca/osbcmmedia/math/mathawm10/glossary/Division03/Reflex%20Angle/index.html>).

My Notes

Full Rotation

A **full rotation** is an angle having a measure of 360° .

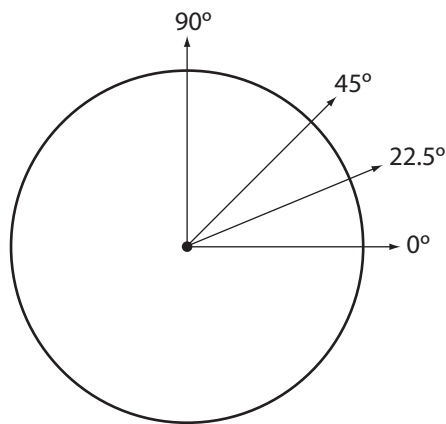
A full rotation angle looks a lot like an angle of 0° . The difference is that, to show a full rotation, we draw a circle around the vertex.



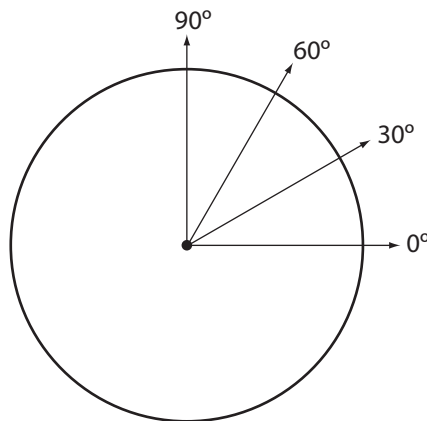
Estimating Angle Measures with Referents

Next, you will estimate angles using the referents you discovered in Explore. You will need the circle diagram you prepared through paper folding and the triangle containing the 30° and 60° angles.

Look at your circle diagram again.



If you were to place 30° and 60° on the circle, those angles would divide the right angle into three parts.

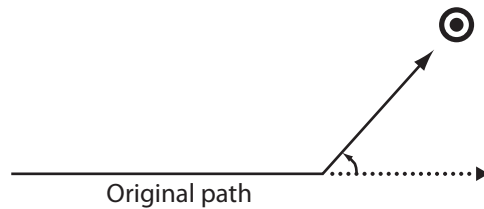


My Notes

Study the following examples to hone your estimation skills. You will be working with acute, obtuse, and reflex angles. You will need a protractor to check the accuracy of the estimates.

Example 1

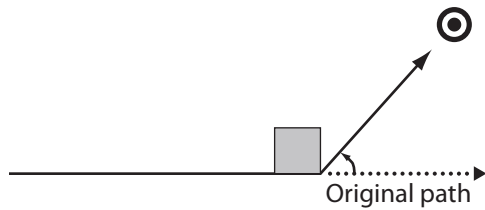
A curling stone strikes a rock in the house and is deflected from its original course.



- State whether the angle is acute, obtuse, or reflex.
- Estimate the angle the stone was deflected.
- Measure the angle to check your estimate.

Solution

- The angle is less than 90° . So the angle is acute.
-



If a square is placed on the figure as shown, the angle appears to be just a little larger than half of a right angle.

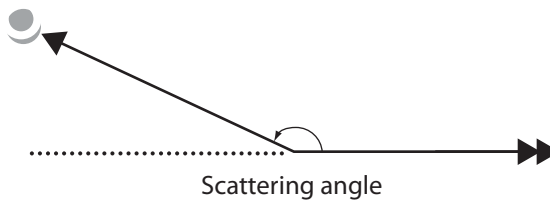
Since $\frac{1}{2} \times 90^\circ = 45^\circ$ (the referent), the angle probably measures about 50° .

- With a protractor, you'll find that the angle measures 48° .

My Notes

Example 2

A proton is fired from the left at the nucleus of a gold atom. The ray with the double arrow head shows the original course of the electron, which it would have taken if it hadn't collided. The electron is scattered from its original course as shown by the ray with the single arrow head.



- State whether the angle is acute, obtuse, or reflex.
- Estimate the scattering angle.
- Measure the angle to check your estimate.

Solution

- The angle is greater than 90° but less than 180° . So the angle is obtuse.
-

If the corner of a sheet of paper is placed on the angle, it looks as though the small angle between the dashed line and the arm of the angle is about one quarter of a right angle (22.5° is the referent). So the scattering angle is about 22.5° less than 180° .

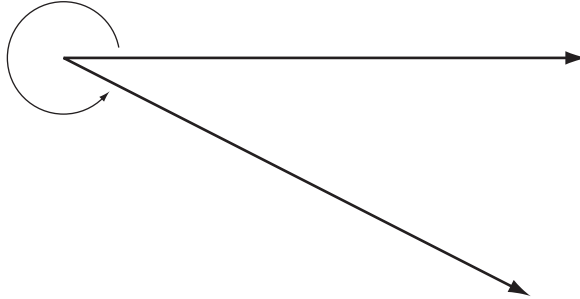
$$180^\circ - 22.5^\circ = 157.5^\circ$$

The scattering angle is approximately 158° .

- Using a protractor, you will find that the angle measures 155° .

Example 3

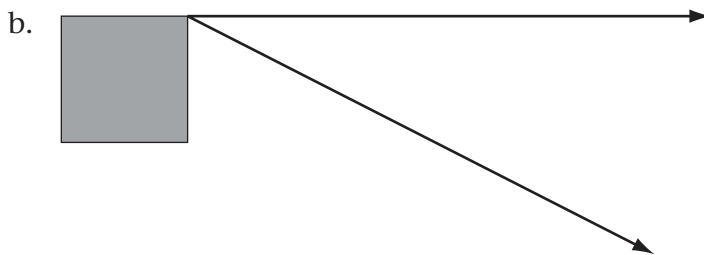
A wrench is turned counter clockwise to loosen a bolt through an angle as shown.



- State whether the angle is acute, obtuse, or reflex.
- Estimate the angle
- Use a protractor to check your estimate.

Solution

- The angle is greater than 180° but less than 360° . The angle is a reflex angle.



If the square corner of a sheet of paper is positioned at the vertex as shown, the small angle appears to be one third of a right angle (30° is the referent). So the reflex angle is about 30° less than one full rotation.

$$360^\circ - 30^\circ = 330^\circ$$

The reflex angle is approximately 330° .

- Using a protractor, the small angle is 27° .

$$360^\circ - 27^\circ = 333^\circ$$

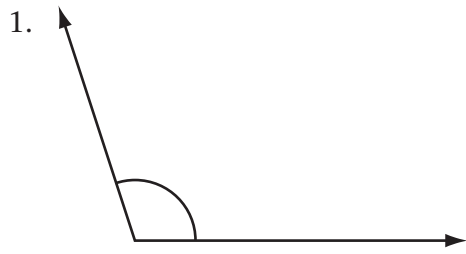
The reflex angle is 333° .

My Notes

Activity 4
Self-Check

Please complete the following questions.

- a. Describe the angle as acute, right, obtuse, straight, reflex, or a full rotation.
- b. Use a referent to estimate the measure. State the referent you used: 22.5° , 30° , 45° , or 60° .
- c. Use a protractor to check your estimate.

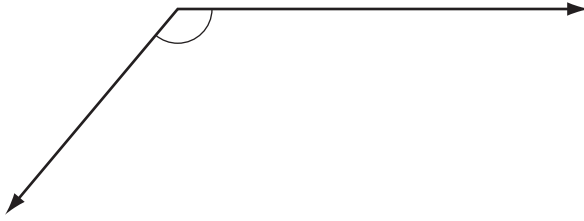


- a. _____

- b. _____

- c. _____

2.



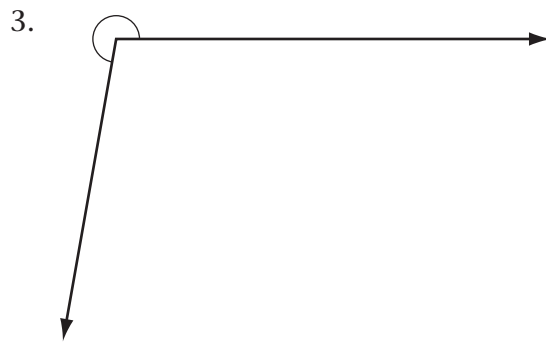
a. _____

b. _____

c. _____

My Notes

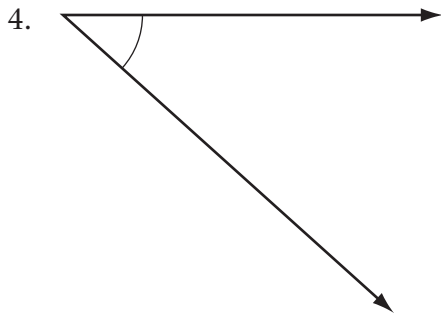
My Notes



a. _____

b. _____

c. _____



My Notes

- a. _____

- b. _____

- c. _____



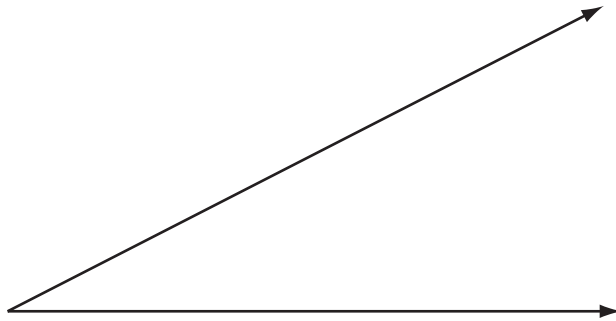
Turn to the solutions at the end of the section and mark your work.

My Notes

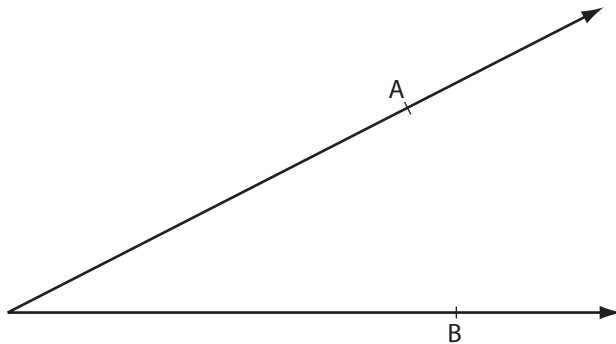
Activity 5 Mastering Concepts

You have seen that referents help in estimating the measure of an angle. But you can also estimate angles using a ruler.

Step 1: Draw any acute angle.



Step 2: From the vertex, measure out 6 cm along each arm and mark these points A and B as shown.



Step 3: Measure the distance between A and B to the nearest tenth of a centimetre.

Step 4: Multiply the distance between A and B by 10. This product will be close to the measure of the angle (within a few degrees). For example, if $AB = 2.3$ cm, then an estimate of the angle would be $2.3 \times 10 = 23$ degrees.

Step 5: Check with a protractor to see how close the estimate was.

My Notes

Try the above procedure with several acute angles. Then, answer the following questions to see why this works.

1. Points A and B are 6 cm from the vertex. If you drew a circle centred at the vertex and passing through A and B, what would its approximate circumference be?

2. What is 10 times this circumference?

3. How does the number of degrees in a circle compare to your answer in Question 2?



Turn to the solutions at the end of the section and mark your work.

My Notes

Lesson Summary

Curling is another game in which predicting the angles at which rocks will travel when struck is a key element of strategy. If you have played the game, there is nothing more satisfying than seeing a well-executed shot. For fans, the satisfaction may be in seeing the side they are cheering for make a double or triple takeout.

In this lesson, you reviewed how protractors are used to sketch and measure angles. From their measures, you described these angles as acute, right, obtuse, straight, reflex, or a full rotation. You also explored angle referents, such as 22.5° , 30° , 45° , and 60° , to estimate the measure of any given angle.



Photo by Phillip Durand © 2010

Lesson B

Constructing Congruent Angles

To complete this lesson, you will need:

- a protractor
- a compass
- a square from a geometry set
- several blank sheets of paper
- a straightedge or ruler
- grid paper from the Appendix at the end of this module

In this lesson, you will complete:

- 5 activities

Essential Questions

- How can you determine if two angles are congruent?
- How can you construct congruent angles?

My Notes

Focus

Lakota star quilts remind us that art and design played an important role in the lives of the First Nation peoples of the prairies and plains. This design represents the Morning Star and signifies a fresh start to a person's life. Blankets and quilts, such as the one in the photograph, were given as gifts to celebrate births, weddings, and other milestones.



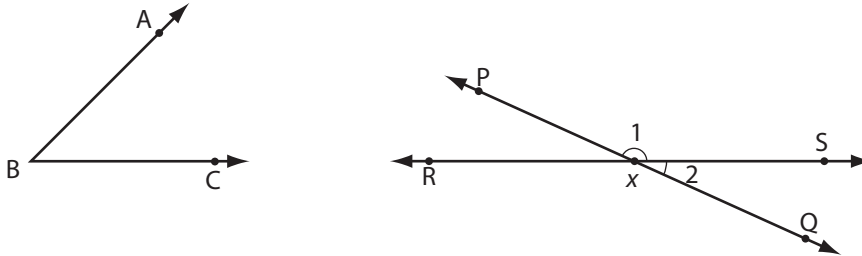
Photo by Alice Day © 2010

The pattern incorporates the repetition of angles and geometric shapes. If you examine the star more closely, you can see how carefully identical—that is, congruent—geometric figures are stitched together to create a star. In the star you can see congruent parallelograms, triangles, rectangles, and trapezoids. How many sets of congruent angles can you find?

Get Started

My Notes

Let's review how to identify angles.



The labels “ $\angle ABC$ ” “ $\angle CBA$ ” and “ $\angle B$ ” can all be used to identify the same angle. However, you can only use the label “ $\angle B$ ” if the angle stands alone as it does in the diagram above. Notice that when a three-letter name is used, the middle letter corresponds to the vertex. Likewise, the vertex is the only letter you can use for a single-letter name.

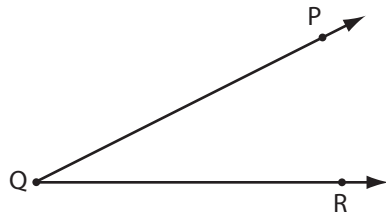
When there are two or more angles that share a vertex, you should not use a single letter label. In the diagram above, line PQ intersects line RS at point X. Referring to “ $\angle X$ ” is confusing in this situation—it could refer to any of four angles. To distinguish among the angles, you must use a three-letter name or you can number the angles. So at the intersection of the lines, $\angle PXS$ is $\angle 1$ and $\angle QXS$ is $\angle 2$.

My Notes

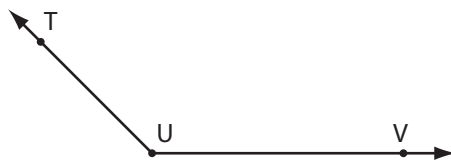
Activity 1
Self-Check

1. Write the name of each angle.

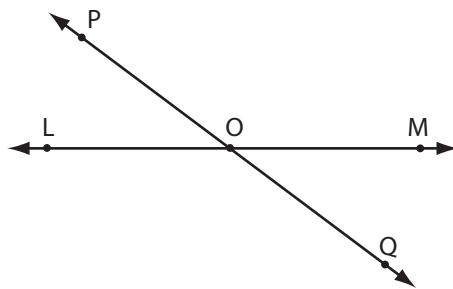
a.



b.



c.



2. Draw and label each angle.

a. $\angle ABC$ is 50°

b. $\angle RST$ is 135°

c. $\angle M$ is 193°

My Notes



Turn to the solutions at the end of the section and mark your work.

My Notes

Explore

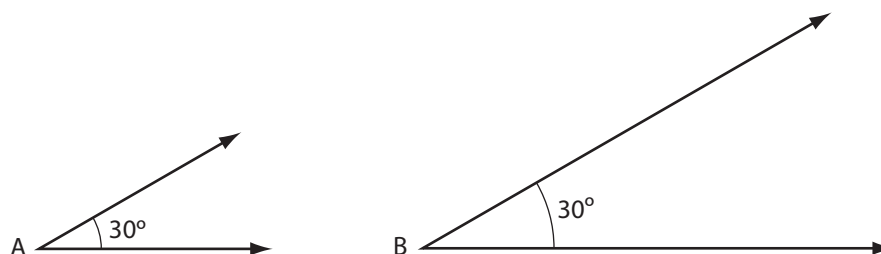
You may recall working with **congruent angles** in previous math courses. Do you remember what a congruent angle is?

Take a look at the images of the star quilt below. Some of the congruent angles are highlighted for you in the quilt. You can use your protractor to find more congruent angles in the quilt.



Photo by Alice Day © 2010

Congruent angles are angles that have the same measure. Please note: congruent angles have the same measure, but their arm-lengths may be different. For example the angles shown below are congruent: they both measure 30° . However, their arm lengths are different.



Mathematicians use the symbol \cong which means “is congruent to.” So, $\angle A \cong \angle B$ means “angle A is congruent to angle B.”

Now, take a few minutes to look around you. Inside or out, there are many examples of congruent angles. For instance, look at where the corner of the room meets the ceiling.

Patterns in nature often display congruent angles. Look for them on images of a snake's skin, a butterfly's wings, and a snowflake. Can you identify the congruent angles in these images?

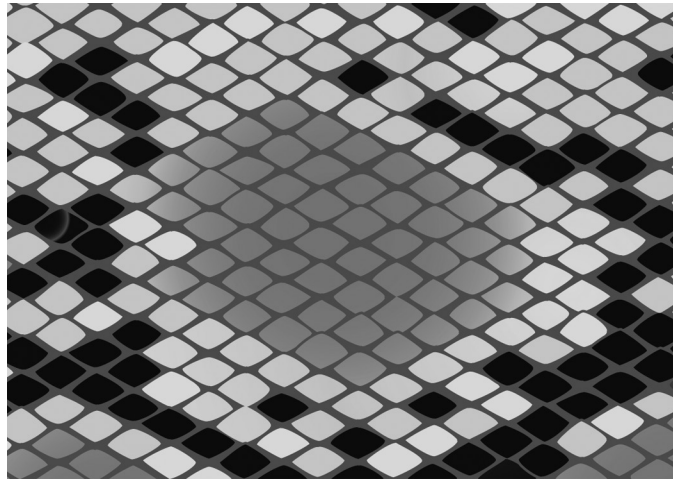


Photo by Outsider © 2010

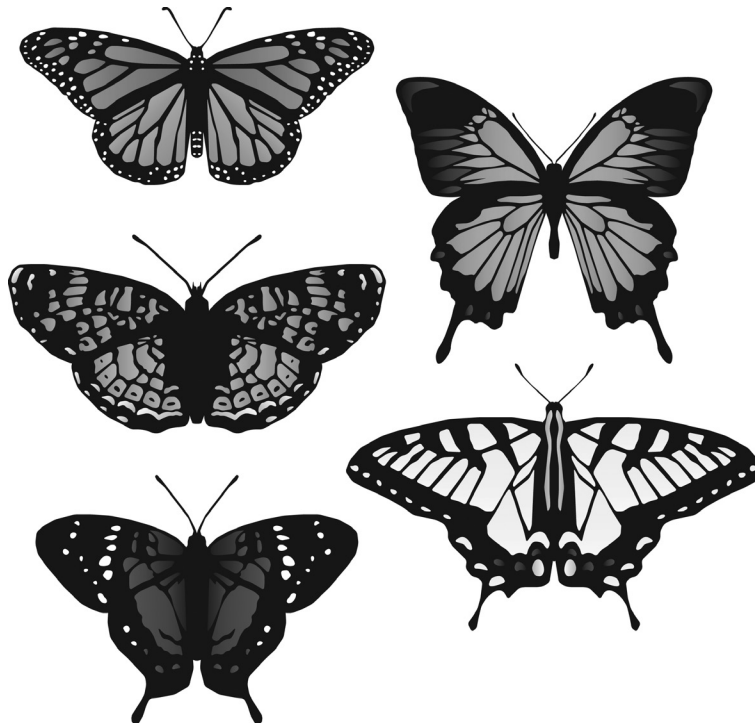


Photo by John David Bigl III © 2010

My Notes

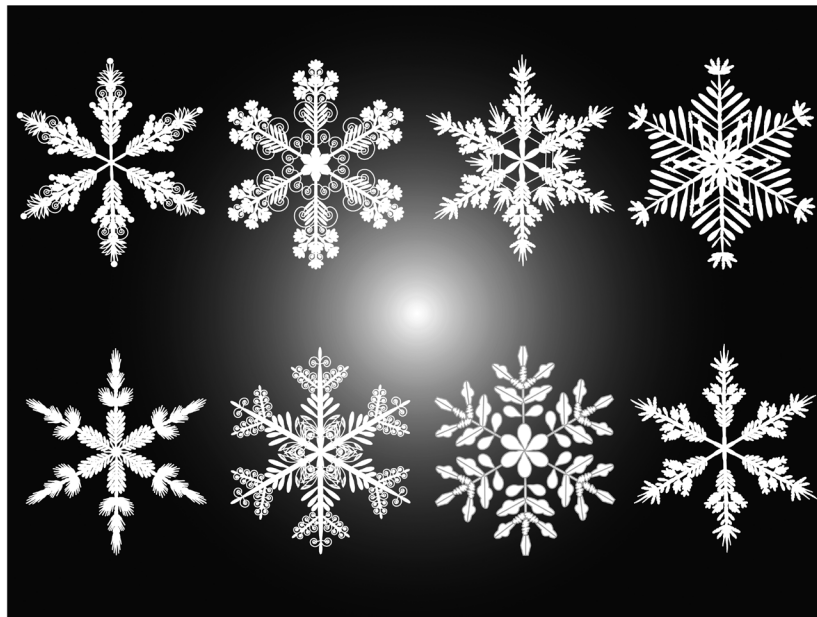
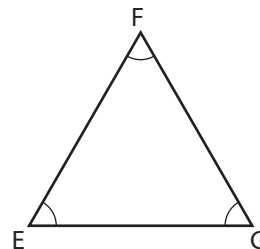


Photo by Inna Petyakina © 2010

As well as in your home or in nature, you encountered congruent angles in geometric shapes you explored in previous mathematics courses.



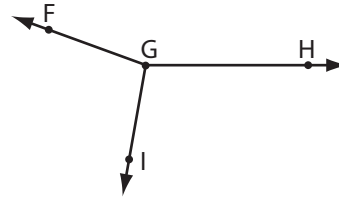
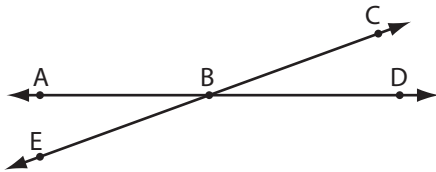
Rectangles have four right angles. Since all right angles measure 90° , the four angles in a rectangle are congruent. Equilateral triangles—triangles whose three sides are equal in length—have three congruent angles. Each of the angles in an equilateral triangle are 60° .

Test out your skills at finding congruent angles by trying the questions in Activity 2.

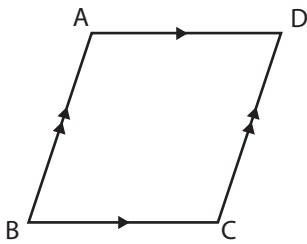
Activity 2 Self-Check

My Notes

- Look at the angles below. Use your protractor to find all the sets of congruent angles.

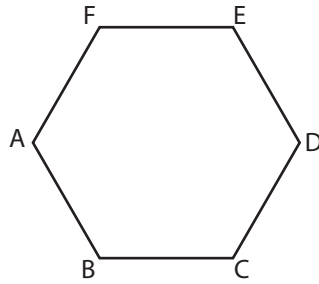


- For each shape below, list the sets of congruent angles. You may use your protractor.
 - ABCD is a parallelogram.

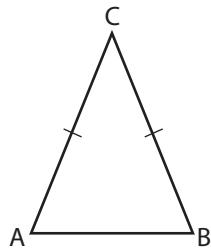


My Notes

- b. ABCDEF is a regular hexagon—a polygon with six equal sides.



- c. ABC is an isosceles triangle—a triangle with two equal sides.



Turn to the solutions at the end of the section and mark your work.

Bringing Ideas Together

My Notes

In Explore, you practised identifying congruent angles. Now, we'll look at a three different ways that you can draw congruent angles:

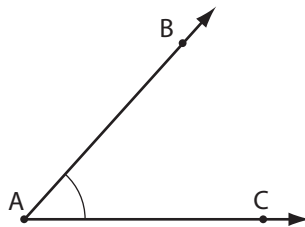
- using a protractor
- folding the page that the angle is drawn on
- using a geometric construction technique

Using a Protractor

The most straightforward method of drawing congruent angles is by using a protractor. You can simply measure the original angle and then draw a second angle of equal measure.

Example 1

Use a protractor to draw an angle that is congruent to $\angle ABC$.



Solution

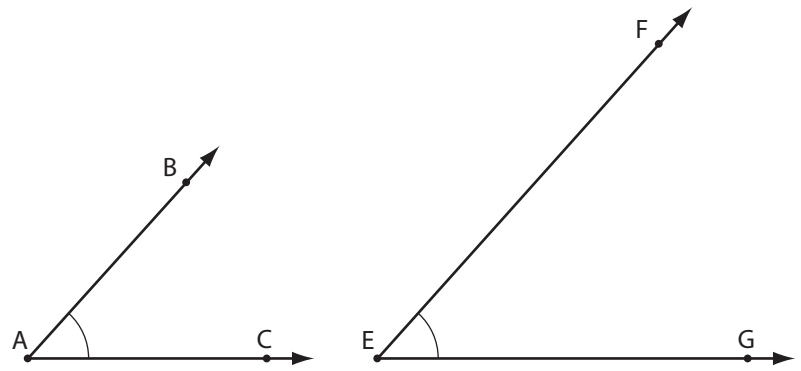
First, use your protractor to measure $\angle ABC$.

$$\angle ABC = 48^\circ$$

Now, use your protractor to draw a 48-degree angle.

Use the **straightedge** on the bottom of your protractor to make the first arm. Then place the centre-point of the protractor on the endpoint of the arm. Find 48° and make a mark on your page. Using the straightedge again, connect the endpoint of the arm to the mark you just made. Label the angle.

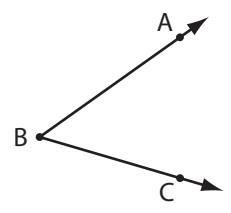
My Notes



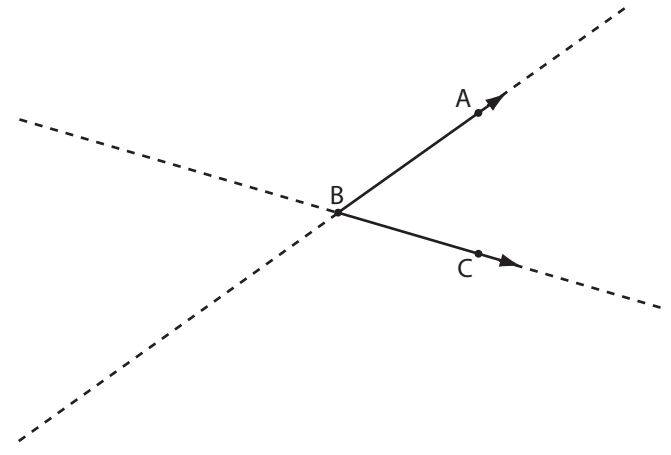
Folding the Page

Another simple technique for creating congruent angles is by folding your page in a very specific way.

Step 1: Draw the angle you want to duplicate on a piece of paper.

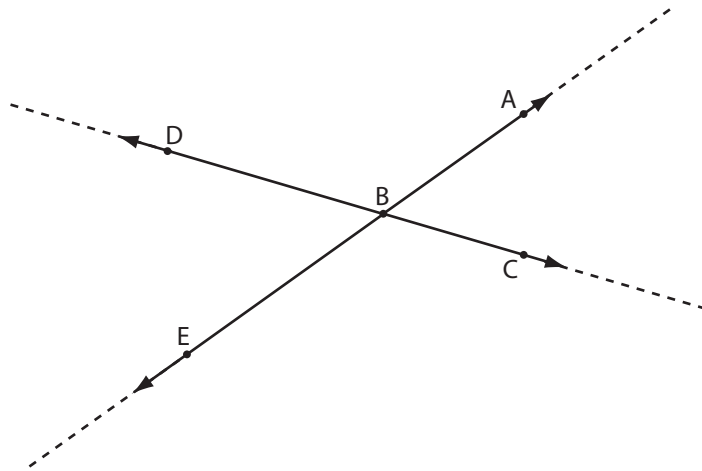


Step 2: Fold the paper along each of the arms. The fold lines are illustrated with dashed lines in the diagram.



My Notes

Step 3: Draw a second angle by tracing the fold lines.

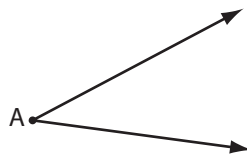


$\angle ABC \cong \angle DBE$. Use your protractor to check that the angles are, in fact, congruent.

Geometric Construction

This method for constructing congruent angles is one that geometers have used for thousands of years. You will use your compass and a straightedge to draw congruent angles.

Follow the steps below to create an angle that is congruent to $\angle A$.



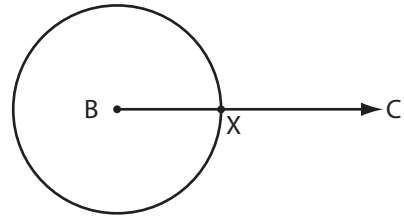
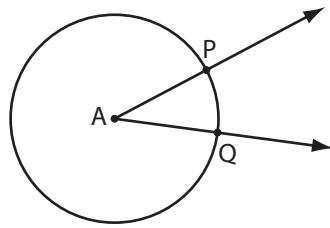
Step 1: Use your straightedge to draw a ray, BC. This will be the lower arm of the new angle. It doesn't have to point in the same direction as the lower arm of $\angle A$, but in this example, we'll draw it that way.



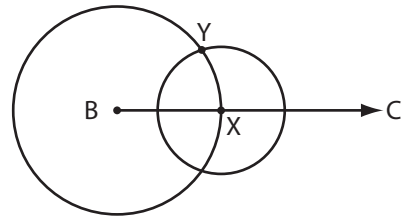
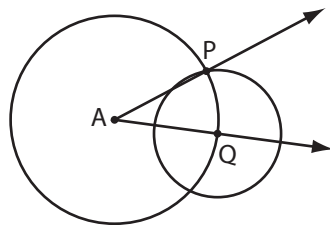
Step 2: Use your compass to draw two circles with the same radius, one centred at A and one centred at B.

My Notes

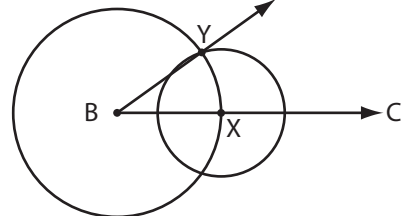
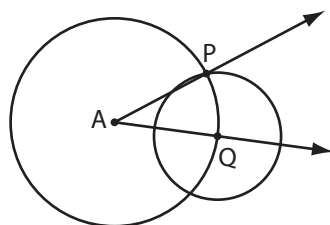
The first circle cuts through the arms of $\angle A$ at two points: P and Q. The second circle cuts across ray BC at the point X.



Step 3: You will draw two more circles. The radii of these two circles will be the distance from P to Q. Place the point of your compass on point Q and the pencil in your compass on point P. Draw a circle. Lift the compass, and with the same radius, draw a circle centred at point X. This circle will intersect with the circle you drew in Step 2. Label this intersection point Y.



Step 4: Use your straightedge to draw ray BY. $\angle A \cong \angle B$.



Now, you should use your protractor to ensure that $\angle A \cong \angle B$.



To view the construction of congruent angles using a compass and straightedge, go and look at *Constructing Congruent Angles* (http://media.openschool.bc.ca/osbcmedia/math/mathawm10/html/congruent_angles/m10_3_m5_009.htm).

Activity 3

Self-Check

My Notes

You will need a protractor, a compass, and a straightedge to complete this activity.

Draw any obtuse angle and label it $\angle ABC$. Use each of the three methods described in this lesson to construct three angles congruent to $\angle ABC$. Then check whether each of the angles you constructed is *actually* congruent to $\angle ABC$.

Original Obtuse Angle

Congruent Angle Using Method 1

My Notes

Congruent Angle Using Method 2

Congruent Angle Using Method 3



Turn to the solutions at the end of the section and mark your work.

My Notes

Stairs and Roofs

In construction, carpenters use their carpenter squares to measure horizontally and vertically to obtain the angle required for projects such as stairs or roofs.

Think of a set of stairs.

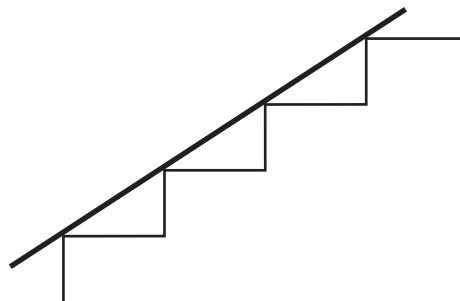


Photo by mrfotos © 2010

The angle of the stairs does not change. Can you suggest a reason why that is the case?

The steps are uniform. The treads (the part of the stairs you step on) are all the same size. The risers (the vertical portion of each step) are all the same size.

This uniformity guarantees that the angles are the same from step to step. You could lay a straight board on the steps to check. The board would rest on all the step edges.



My Notes

The ratio of the riser height to the tread length affects the steepness, that is, the angle, of the stairway. In other words, the vertical and horizontal heights of a stairway affect its angle. Also for a roof, vertical and horizontal distances affect the angle of the roof.

The following is an example of how the slope of a roof can be determined from vertical and horizontal distances.

Example 2



Photo by Jim Parkin © 2010

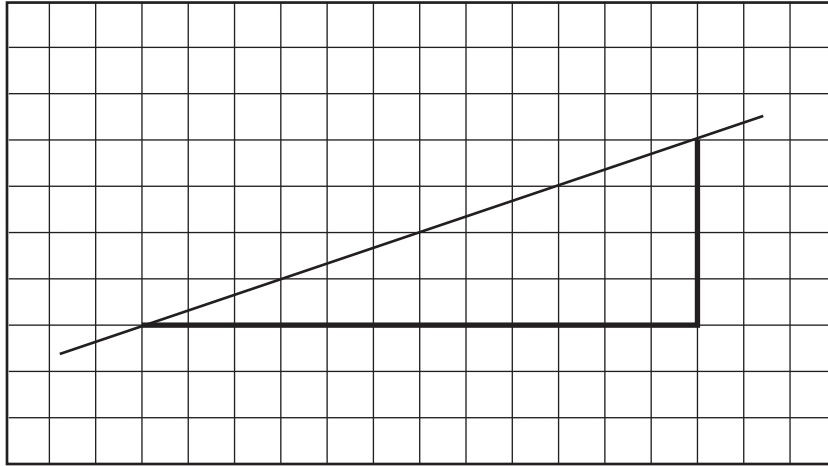
Akiko and her father are building a house and an attached garage. The slope of the garage roof is a 4 inch rise for every 12 inch measured horizontally.

- a. Draw a diagram of the roof using grid paper.
- b. Measure the angle of the roof rises from your diagram.

Solution

Use one square to represent one inch.

a.



b. Use your protractor to measure the angle.

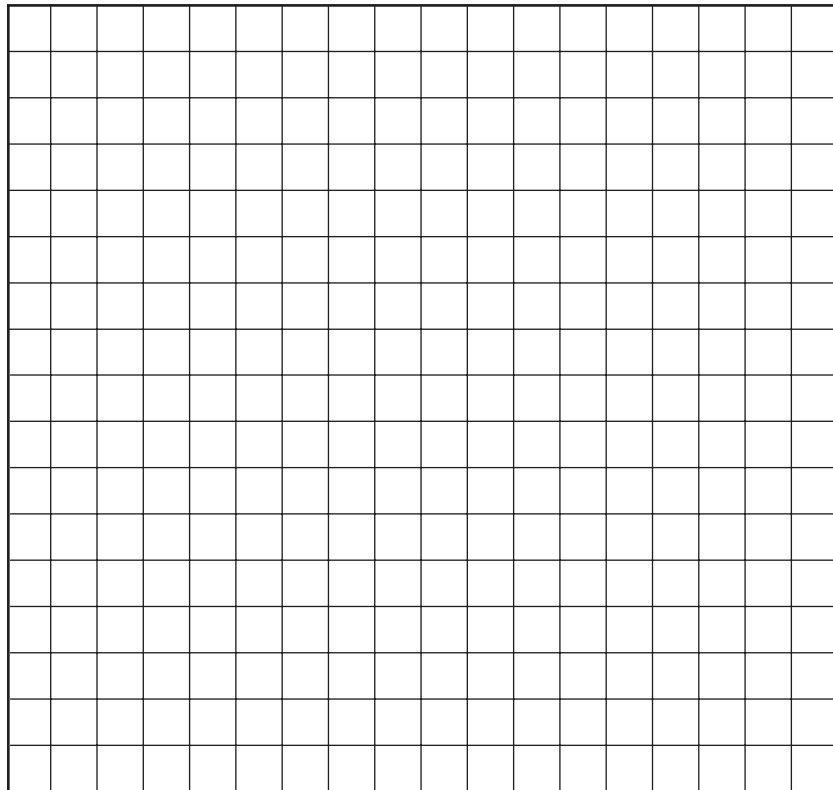
The angle of the roof is approximately 18.5° .

My Notes

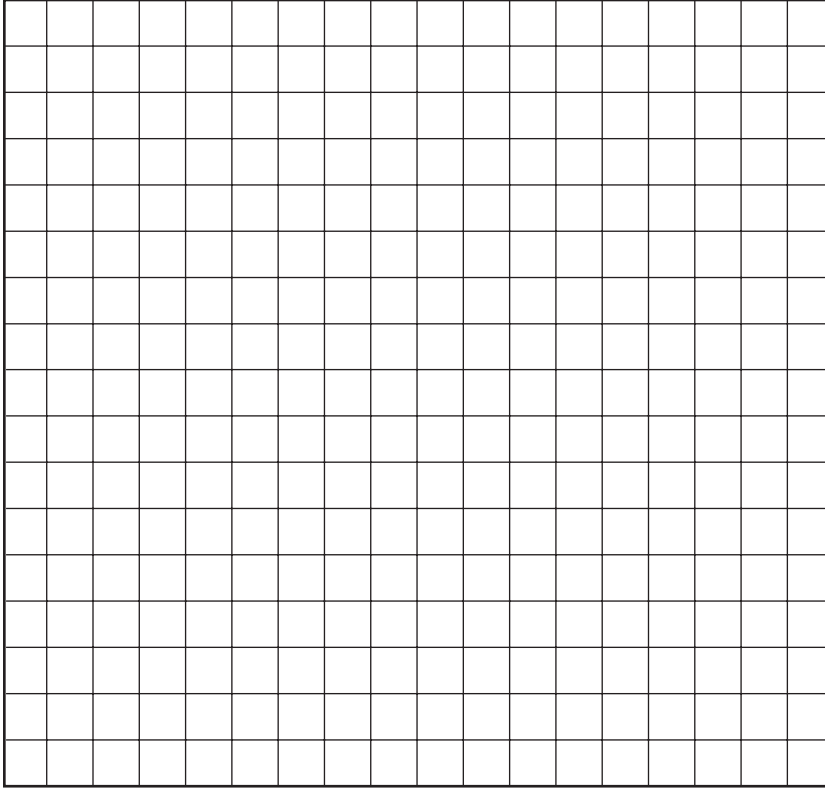
My Notes

Activity 4
Self-Check

1. For a roof that slopes at 45° , what is the rise (in inches) for a horizontal run of 12 in?



2. Determine the angle at which a ladder rests against a vertical wall. The foot of the ladder is 3 ft from the wall, and the top of the ladder rests against the wall 8 ft above the ground.



Turn to the solutions at the end of the section and mark your work.

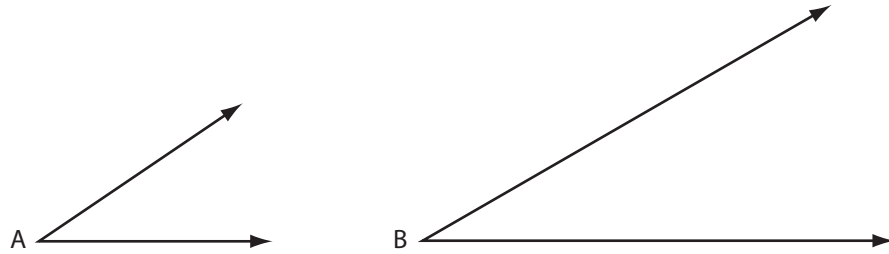
My Notes

My Notes

Activity 5 Mastering Concepts

To do this question you will need your protractor.

Compare the following angles.



Which of the following statements best describes the relationship between $\angle A$ and $\angle B$?

- $\angle A$ is smaller than $\angle B$
- $\angle A$ is congruent to $\angle B$
- $\angle A$ is larger than $\angle B$

Justify your answer.

Lesson Summary

My Notes



Photo by Ingvald Kaldhussater © 2010

The game being played in the photograph involves first folding a square sheet of paper into the shape shown and then opening and closing the shape as a name is spelled or a number is counted out. The process of folding a piece of paper into various shapes is a traditional Japanese folk art called *origami*. The folds create an interplay of angles and geometric shapes. Can you identify some congruent angles in the figure?

Lesson C

Bisecting Angles

To complete this lesson, you will need:

- a mirror
- a protractor
- a compass
- a square from a geometry set
- several blank sheets of paper
- a straightedge or ruler

In this lesson, you will complete:

- 5 activities

Essential Questions

- What does it mean to bisect an angle?
- How are different techniques used to bisect angles?

My Notes

Focus



Photo by James Steidl © 2010

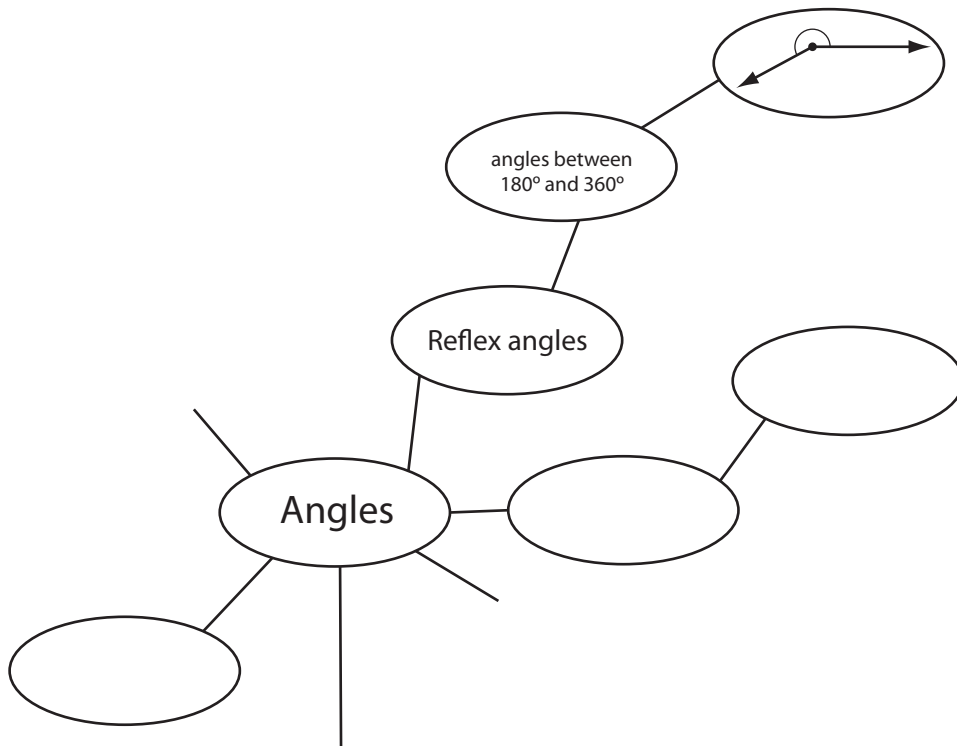
Have a look at the baseball diamond in the picture above. The first and third base lines form the angle that determines whether a ball is hit fair or foul. Second base, the pitcher's mound, and home plate split that angle into halves. What is the measure of each half of that angle?

In this lesson you will continue to explore the geometry of angles and learn about the lines that divide angles into halves.

Get Started

My Notes

To warm-up for this lesson, review what you've learned so far about angles. Complete the following mindmap using what you know about angles. You can fill in some of the empty bubbles and/or create your own. Feel free to look back at Lessons A and B to refresh your memory. You may also include things you learned in other courses about angles.



My Notes

Explore

You may recall, from your previous math experience, finding the midpoint of a line segment. The midpoint of a line divides the line segment in half—that is, into two equal parts. The term we use in geometry to describe dividing something in half is **bisect**.

So far in this section, you’ve worked with several types of angles. You will continue to work with angles in this lesson. In fact, you will learn to bisect angles using a variety of methods.

Can you think of some different ways to divide an acute angle into two equal parts? What about other types of angles?

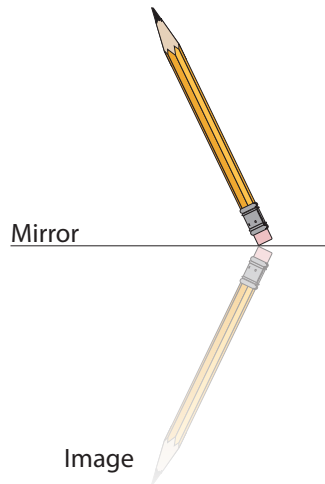
Activity 1
Try This

My Notes

You will need a pen or pencil and a mirror to complete this activity.

Step 1: Take a pencil (or pen) and place one end against a mirror.

Notice that the pencil and its image form an angle, with the vertex located at the point where the pencil touches the mirror.




Step 2: Change the size of the angle between the pencil and its image, all the while keeping the end of the pencil on the mirror.

Questions:

1. Compare the size of the angle created between the mirror and the pencil with the size of the angle created between the mirror and the pencil's image. What do you notice?

My Notes

2. Compare the size of the angle created between the mirror and the pencil with the size of the angle created between the pencil and its image. What do you notice?

 Turn to the solutions at the end of the section and mark your work.

Symmetry

Bisecting an angle is like creating a line of symmetry through an angle. In Activity 1, the mirror acted as the angle **bisector** of the angle created by the pencil and its image. An angle bisector always divides an angle into two identical halves.

Bisectors are common features in design, nature, and art.

For example, look at the veins in a leaf. In a maple leaf, as in most other leaves, there is **symmetry**. One half of the leaf is the mirror image of the other.



Photo by Marta Tobolova © 2010

Can you sketch an angle and its bisector formed by the veins in the leaf?

The angles formed by the veins are bisected by the central vein

running from the stem to the top of the leaf. An angle and its bisector are drawn on the leaf below.

My Notes



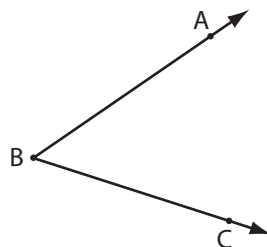
Photo by Marta Tobolova © 2010

Notice that $\angle ABD$ measures the same as $\angle CBD$. Or, $\angle ABD \cong \angle CBD$.

We can say that an angle bisector divides an angle into two congruent halves. Now, how do we find the bisector of an angle?

Activity 2
Try This

Step 1: On a blank sheet of paper, draw any angle and label it $\angle ABC$. Measure and record the size of $\angle ABC$



My Notes

Step 2: Experiment with different folding methods. Your goal is to fold the sheet of paper to construct the bisector of $\angle ABC$.

Step 3: Label the bisector BD.

Step 4: Measure and record the size of $\angle ABD$ and $\angle CBD$.

Questions:

1. Explain how you formed the bisector of $\angle ABC$ by paper folding.

2. Give the reason why the line you labelled BD must be the angle bisector.

3. State the measures of $\angle ABC$, $\angle ABD$ and $\angle CBD$. How are these measures related?



Turn to the solutions at the end of the section and mark your work.

Bringing Ideas Together

My Notes

In Explore, you examined what it means to bisect an angle. You also learned one technique for finding the angle bisector: by folding! Now, we'll look at three more methods for finding the angle bisector using geometry tools. The three methods you'll learn are:

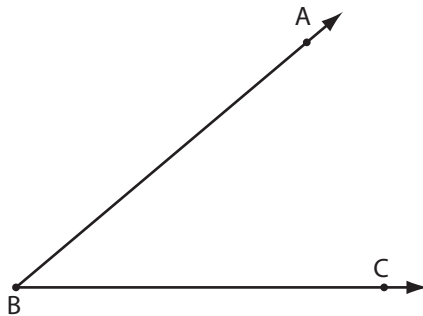
- Using a Protractor
- Geometric Construction: Compass and Straightedge
- Geometric Construction: Carpenter's Square

Using a Protractor

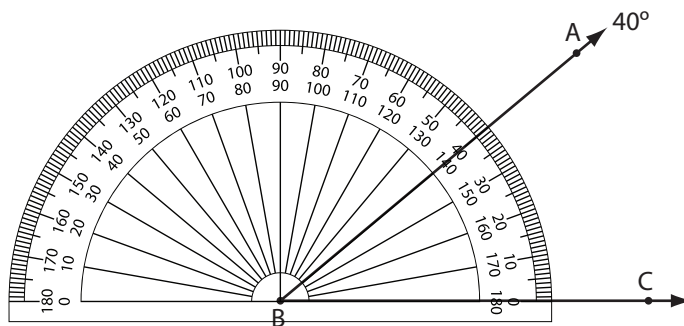
One simple method for finding the bisector of an angle is to use a protractor. Work through the example below to see how this is done.

Example 1

Bisect $\angle ABC$.



Step 1: Use your protractor to measure the angle you intend to bisect.

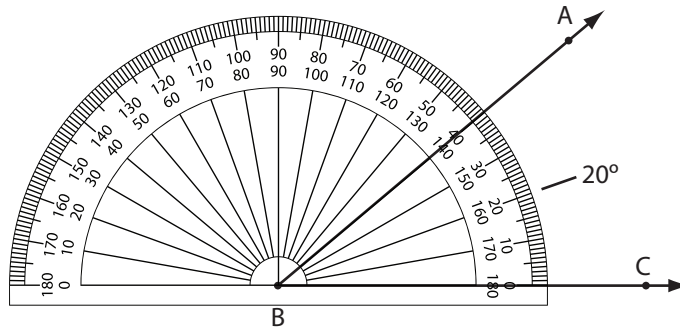


My Notes

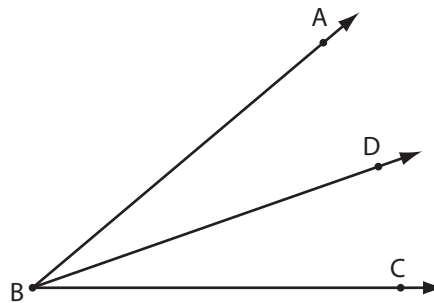
Step 2: Divide the measurement in half.

$$40^\circ \div 2 = 20^\circ$$

Step 3: Line up the protractor so that the centre-point is on the vertex and the baseline runs along one arm of the angle. Make a mark on the page at the half-measurement you determined in Step 2.



Step 4: Draw a line from the vertex of the angle to the mark you made in Step 3. This is your angle bisector.



Measure $\angle ABD$ to make sure it is, in fact, the same size as $\angle CBD$.

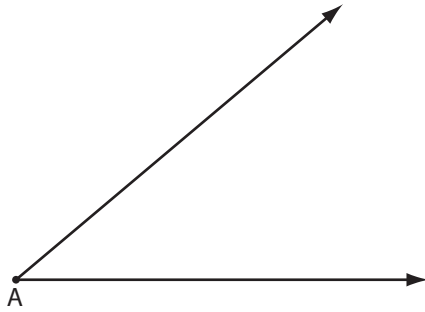
Geometric Construction: Compass and Straightedge

In Lesson B you constructed a congruent angle using only a compass and a straightedge. Now, you will construct the bisector of an angle using this classical approach—one that geometers have used for thousands of years.

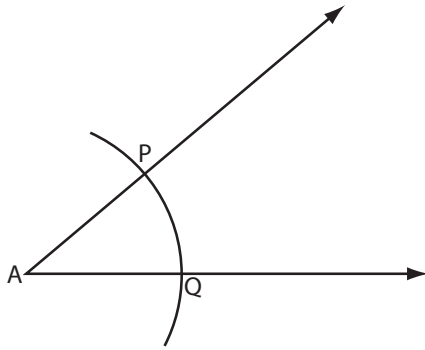
My Notes

Example 2

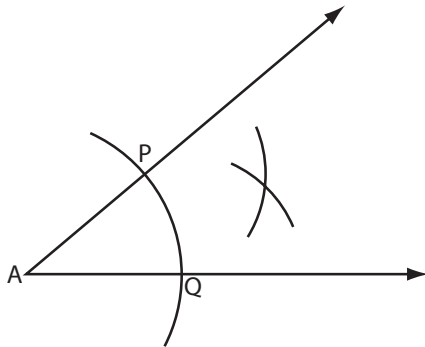
Use compasses and a straight edge to bisect $\angle A$.



Step 1: Set your compass to a suitable radius. With centre A, the vertex of the angle, draw an arc of a circle cutting the arms of the angle at points P and Q.

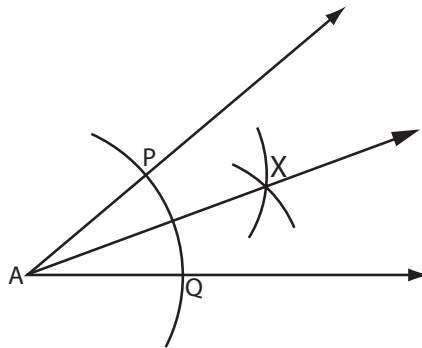


Step 2: Open your compasses to a radius that is at least greater than one-half the distance between points P and Q. With centre at P, draw an arc between the arms of $\angle A$. Then, with centre at Q, draw a second arc between the arms of $\angle A$. Name the point where these arcs intersect, X.



My Notes

Step 3: Draw ray AX.



Use your protractor to measure $\angle A$, $\angle PAX$, and $\angle XAQ$.

If the work is done carefully, $\angle PAX \cong \angle XAQ$; that is, both angles are equal in measure.

And, $\angle PAX = \angle XAQ = \frac{1}{2}\angle A$.



To see a demonstration of this method, go and look at *Bisect an Angle* (<http://media.openschool.bc.ca/osbcmedia/math/mathawm10/glossary/Division03/BisectAngle/index.html>).

Activity 3

Self-Check

My Notes

Do these questions. When you are finished, check your answers.

1. Draw any obtuse angle. Use your compasses and a straightedge to bisect the angle. Check the accuracy of your construction with your protractor.

My Notes

2. A student bisected a 234° angle. A protractor was used to measure each half. The student said that each half was 63° . What mistake might have been made? How large should each half have been?



Turn to the solutions at the end of the section and mark your work.

Geometric Construction: Carpenter's Square

My Notes

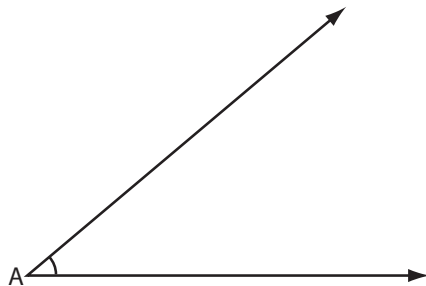


Photo by Tom Oliveira © 2010

In construction, a carpenter would use his or her carpenter's square to bisect angles. You can use one of the squares from your geometry set to bisect an angle.

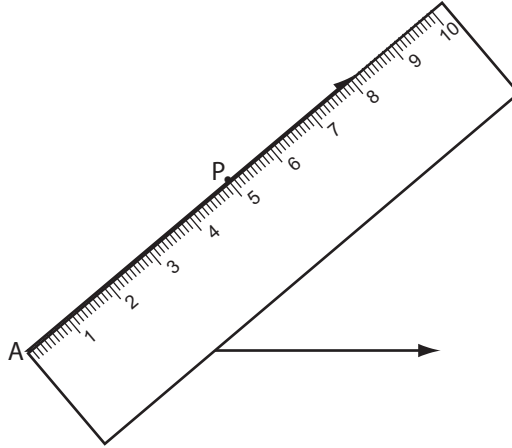
Example 3

Bisect $\angle A$ using a carpenter's square.

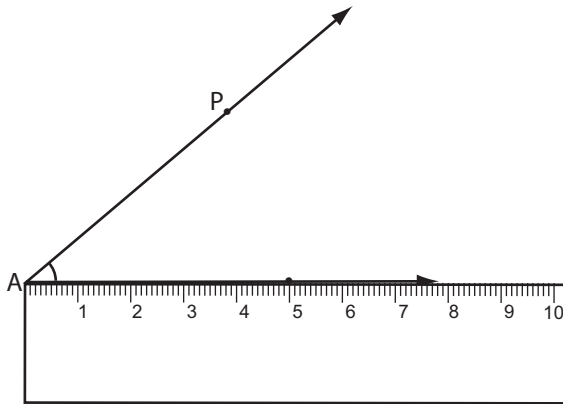


My Notes

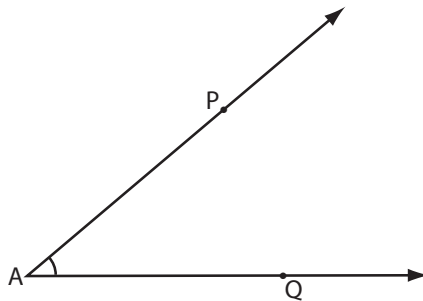
Step 1: From vertex A, measure out a specified distance along the arm. In this example we will use 5 cm. Mark and label the first point P.



Step 2: Measure out the same distance along the other arm of angle A. Mark and label this point Q.

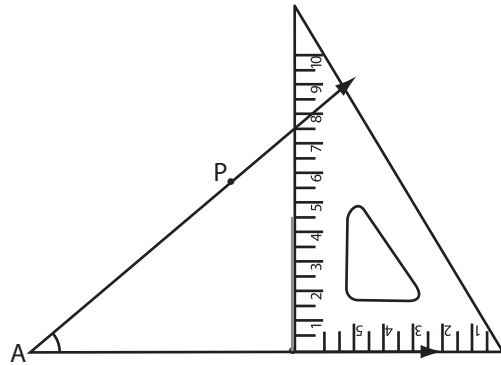


Your angle should now look like this:

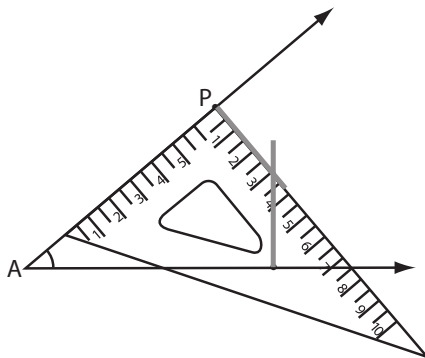


My Notes

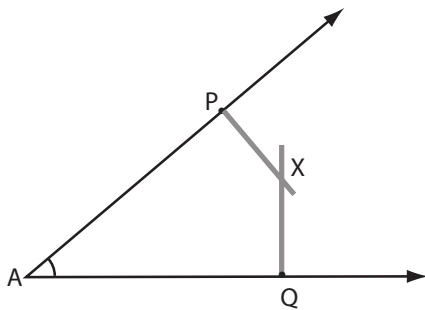
Step 3: Place the right angle of your square along the arm at point Q. Draw a line along the square towards the centre of the angle.



Step 4: Place the right angle of your square along the arm at point P. Draw a line along the square towards the centre of the angle.

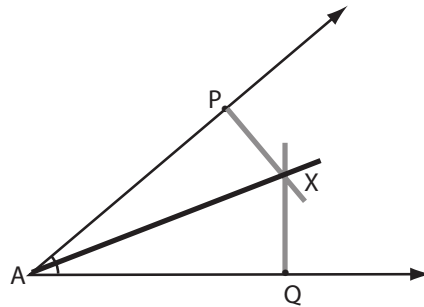


Step 5: Name the point where the lines cross, X.



My Notes

Step 6: Draw ray AX.



Ray AX bisects angle A. You can use a protractor to check that this is true.



To see the technique of bisecting an angle using a square, go and look at *Bisect an Angle Using a Square* (http://media.openschool.bc.ca/osbcmmedia/math/mathawm10/html/m10_3_m5_013/m10_3_m5_013.htm).

Activity 4
Self-Check

My Notes

Use the Carpenter's square method to bisect a 120° angle.



Turn to the solutions at the end of the section and mark your work.

My Notes

Activity 5

Mastering Concepts

Zander says he can bisect a 300° angle by bisecting the 60° angle that completes the full rotation and extending the bisector of the 60° angle in both directions. Is he correct?

If he is correct, explain why. If he is incorrect, explain why.



Turn to the solutions at the end of the section and mark your work.

Lesson Summary

My Notes



Photo by Pichugin Dmitry © 2010

Many photographs and paintings of alpine scenery involve reflections in the mirror surfaces of the mountain lakes. The angles formed by the mountains and their reflections are bisected at the shoreline. This lesson involved similar relations between the arms of angles and the bisectors of those angles. Bisectors behave like mirrors, reflecting each arm into the other.

In this lesson, you investigated a variety of techniques that can be used to construct angle bisectors. You constructed angle bisectors by paper folding, using a protractor using a compass and a straightedge, and using squares from a geometry set.

Lesson D

Relationships Among Angles

To complete this lesson, you will need:

- a protractor
- scissors
- several blank sheets of paper
- a straightedge or ruler

In this lesson, you will complete:

- 6 activities

Essential Questions

- What are some of the relationships between sets of angles?
- How can classifying the relationships between sets of angles help you solve problems?

My Notes

Focus

Seeking patterns and relationships is a function of the human mind. Art and architecture, games and music all make use of patterns. The same is true of math, and specifically geometry. Look at the interplay between light and shadows by the goal on the soccer pitch in the photo. The photographer knew that the lines, shapes, and variety of angles would make this an interesting photograph.



Photo by Tina Rencelj © 2010

The shadow of the goal post nearest you divides a right angle into two acute angles as you can see in the second image. What terms describe this angle pair?

Get Started

You may have studied triangles in previous courses. Do you remember anything about the relationship between the angles of a triangle?

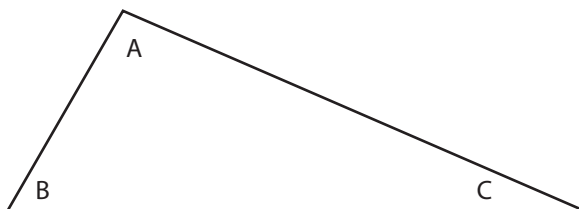
Activity 1

Try This

My Notes

You will need a protractor to complete this activity.

Step 1: On a blank sheet of paper, draw a triangle of any shape and size. Label the angles as shown.



Step 2: Measure the three angles with a protractor. Record these measures.

$$\angle A = \underline{\hspace{2cm}}$$

$$\angle B = \underline{\hspace{2cm}}$$

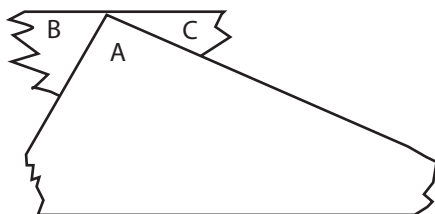
$$\angle C = \underline{\hspace{2cm}}$$

Step 2: Calculate the sum of the angles.

$$\angle A + \angle B + \angle C = \underline{\hspace{2cm}}$$

Step 3: Cut out the triangle, and then tear off angles B and C.

Step 4: Place angles B and C next to $\angle A$ so that all three vertices lie at the same point.



Step 5: Repeat Steps 1–4 for a different triangle.

My Notes

Questions

1. What do you notice about the angle formed after Step 4?

2. Will the sum of the angles in a triangle be the same for any triangle you draw?



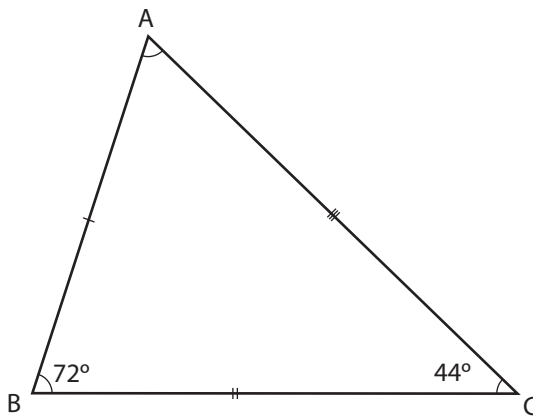
Turn to the solutions at the end of the section and mark your work.

Angles in a Triangle

The sum of the angles in any triangle is 180° . Let's apply this relationship.

Example 1

Find the missing measure of $\angle A$.



Solution

In a triangle, all the angles add up to 180° , so the following must be true:

$$\angle A + \angle B + \angle C = 180^\circ$$

$$\angle A + 72^\circ + 44^\circ = 180^\circ$$

$$\angle A + 116^\circ = 180^\circ$$

$$\angle A = 180^\circ - 116^\circ$$

$$\angle A = 64^\circ$$

Subtract 116 from both sides of the equation to isolate $\angle A$.

My Notes

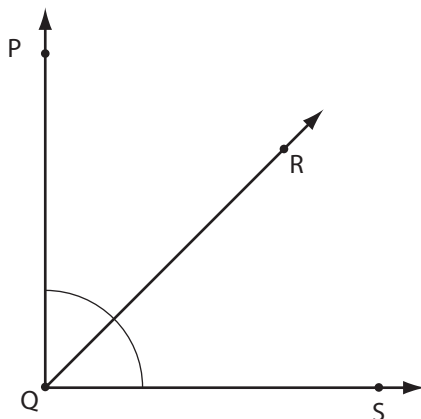
Explore

In Get Started, you reviewed the relationship between the angles in a triangle. Now, you will look at several relationships between pairs of angles.

Adjacent Angles

The word *adjacent* means *neighbouring* or *nearby*. **Adjacent angles** are angles that share a vertex and an arm. If it helps you remember, you can think of them as neighbours.

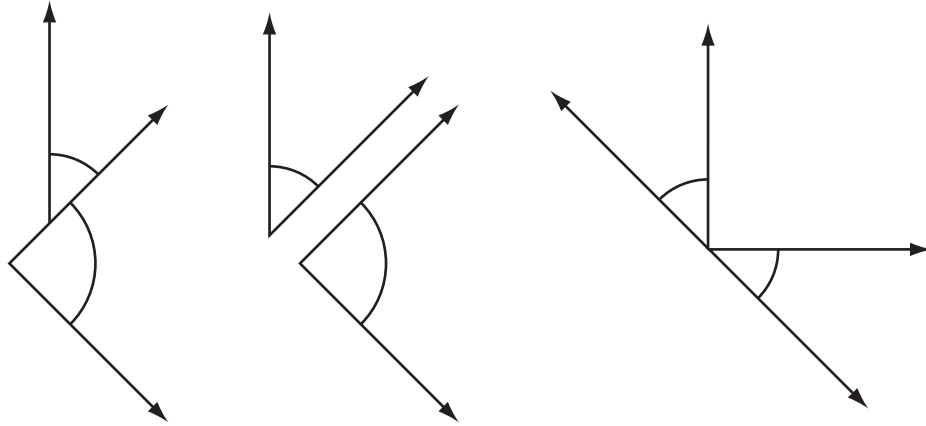
In the diagram below, $\angle PQR$ and $\angle RQS$ are adjacent angles.



My Notes

Activity 2
Self-Check

This illustration shows three pairs of angles.



Explain why none of these pairs are adjacent angles.



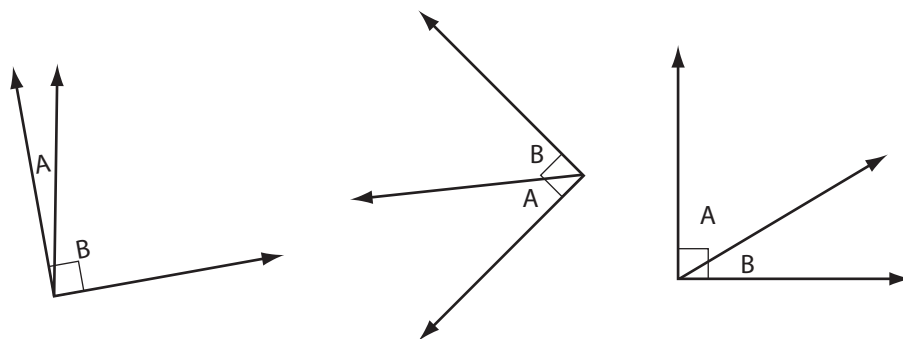
Turn to the solutions at the end of the section and mark your work.

My Notes

Complementary Angles

There is a special connection between the sizes of adjacent angles making up a right angle.

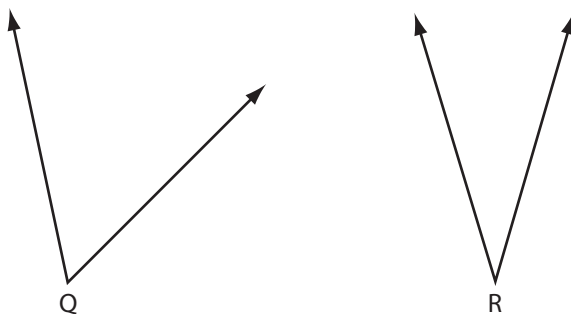
Look at angles A and B in the following frames.



$$\angle A + \angle B = \underline{\hspace{2cm}}$$

From the diagrams, you should see that $\angle A + \angle B = 90^\circ$. Two angles whose sum is 90° are said to be **complementary angles**. The angles in the diagrams above are both complementary and adjacent. However, not all complementary angles are adjacent.

The angles shown below are complementary, but not adjacent. Use your protractor to measure these angles and ensure they are complementary.



$$\begin{aligned} \angle Q + \angle R &= \underline{\hspace{1cm}} + \underline{\hspace{1cm}} \\ &= \underline{\hspace{2cm}} \end{aligned}$$

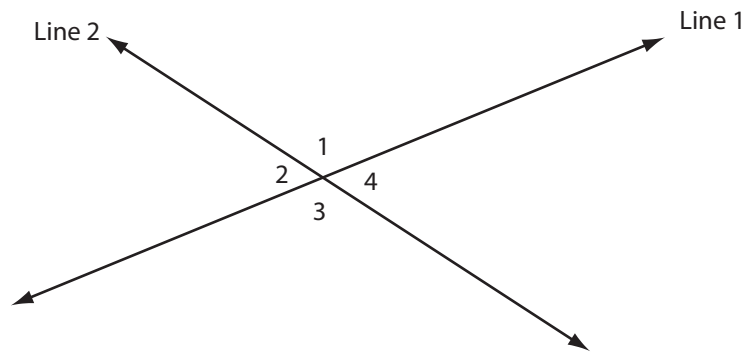
You should have seen that angle Q is 57° and angle R is 33° . The sum of the angle measures is 90° and therefore the angles are complementary.

My Notes

Intersecting Lines

The sizes of adjacent angles at the intersection of two lines are connected in a special way.

Can you identify pairs of adjacent angles at the intersection of Line 1 and Line 2?



The following are pairs of adjacent angles:

- $\angle 1$ and $\angle 2$
- $\angle 1$ and $\angle 4$
- $\angle 3$ and $\angle 4$
- $\angle 2$ and $\angle 3$

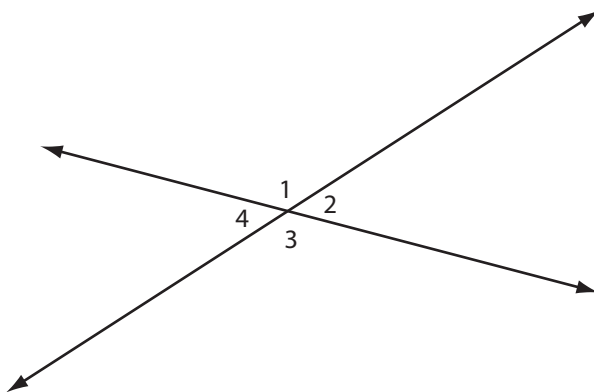
In the next activity you will explore the relationships between the angles formed at the intersection point of two lines.

Activity 3
Try This

My Notes

You will need a protractor to complete this activity.

Two intersecting lines are shown below. Use this diagram as you work through the activity.



- Use your protractor to measure each of the four angles. Record your measurements below.

$$\angle 1 = \underline{\hspace{2cm}}$$

$$\angle 2 = \underline{\hspace{2cm}}$$

$$\angle 3 = \underline{\hspace{2cm}}$$

$$\angle 4 = \underline{\hspace{2cm}}$$

- Find the sum of the measures of each pair of adjacent angles. Record your answers below.

$$\angle 1 + \angle 2 = \underline{\hspace{2cm}}$$

$$\angle 1 + \angle 4 = \underline{\hspace{2cm}}$$

$$\angle 3 + \angle 4 = \underline{\hspace{2cm}}$$

$$\angle 2 + \angle 3 = \underline{\hspace{2cm}}$$

My Notes

3. What do you notice about the sum of the measures of adjacent angles formed by intersecting lines?

4. a. What do you notice about $\angle 1$ and $\angle 3$?

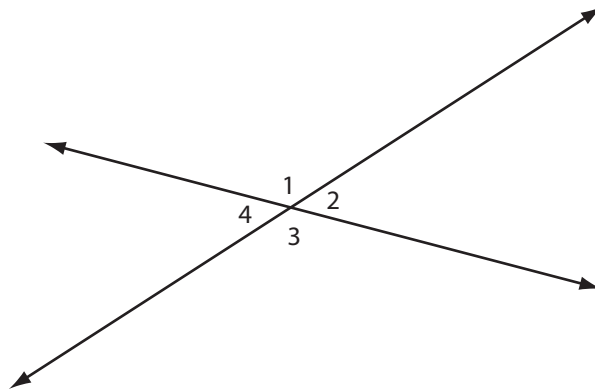
b. What do you notice about $\angle 2$ and $\angle 4$?



Turn to the solutions at the end of the section and mark your work.

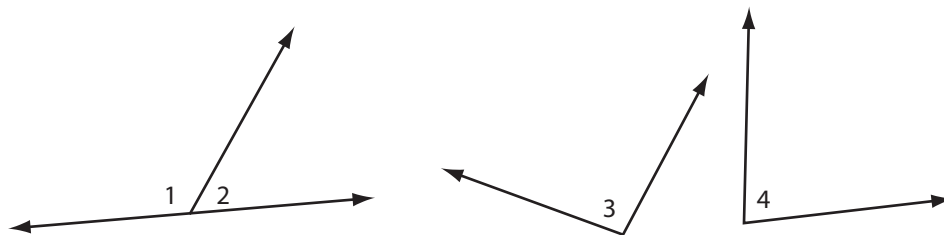
Supplementary Angles

The diagram below is the same as the one you used in Activity 3.



You found that the measures of each of the pairs of adjacent angles formed by the two intersecting lines add up to 180° . This is because the angles in each pair combine to form a straight line. Angles whose measures add up to 180° are called **supplementary angles**.

As you saw in Activity 3, some supplementary angles are adjacent. However, not all supplementary angles are adjacent. The diagram below shows two sets of supplementary angles. Use your protractor to measure the angles and ensure that each pair is, in fact, supplementary.

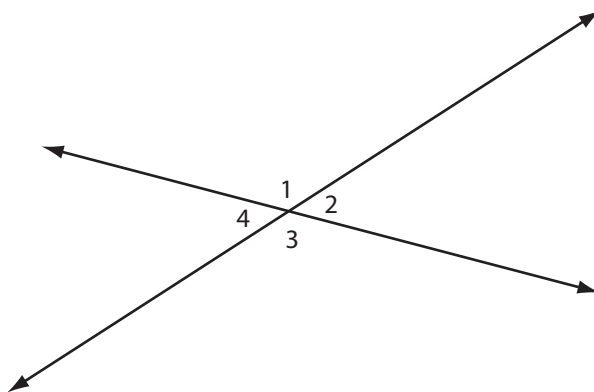


$$\angle 1 + \angle 2 = \underline{\quad} + \underline{\quad} = \underline{\quad} \quad \angle 3 + \angle 4 = \underline{\quad} + \underline{\quad} = \underline{\quad}$$

You should have found that angle 1 is 124° and angle 2 is 56° . The sum of the angle measures is 180° and therefore the angles are supplementary. Further, angle 3 is 98° and angle 4 is 82° . The sum of the angle measures is 180° and therefore the angles are supplementary.

Opposite Angles

The diagram below is the same as the one you used in Activity 3.



You found that the measures of $\angle 1$ and $\angle 3$ are equal, and so are the measures of $\angle 2$ and $\angle 4$. We can say that $\angle 1$ and $\angle 3$ are congruent and $\angle 2$ and $\angle 4$ are congruent.

Have a look at where these pairs of angles are located in the diagram above. $\angle 1$ and $\angle 3$ share a vertex and are opposite each other. $\angle 2$ and $\angle 4$ also share a vertex and are opposite each other. Notice that these pairs of angles are not adjacent.

My Notes

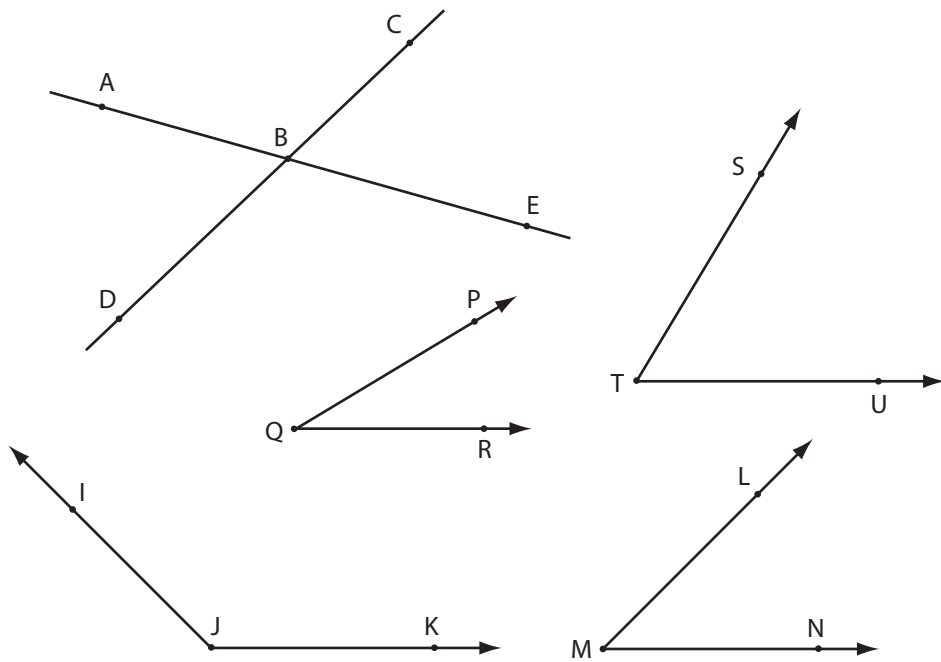
These pairs of angles are called **vertically opposite angles** or simply *opposite angles*. Opposite angles are created when two lines intersect. In the diagram above, $\angle 1$ and $\angle 3$ are opposite angles. $\angle 2$ and $\angle 4$ are also opposite angles.



To explore opposite angles further, go and look at *Angle Relationships* and then *Opposite Angles* (<http://media.openschool.bc.ca/osbcmmedia/math/mathawm10/glossary/Division03/OppositeAngles/index.html>). You can move the lines to adjust the sizes of the angles.

Activity 4
Self-Check

You will need a protractor to complete this activity.



Using the diagram above, identify all the pairs of angles that are:

1. adjacent

2. complementary

3. supplementary

4. vertically opposite



Turn to the solutions at the end of the section and mark your work.

My Notes

My Notes

Bringing Ideas Together

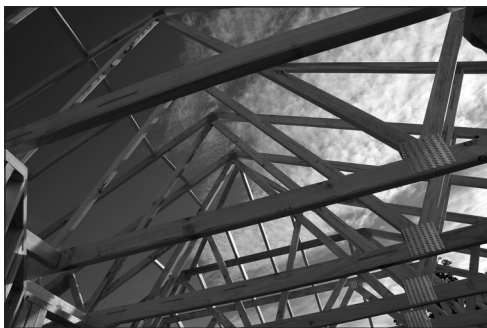
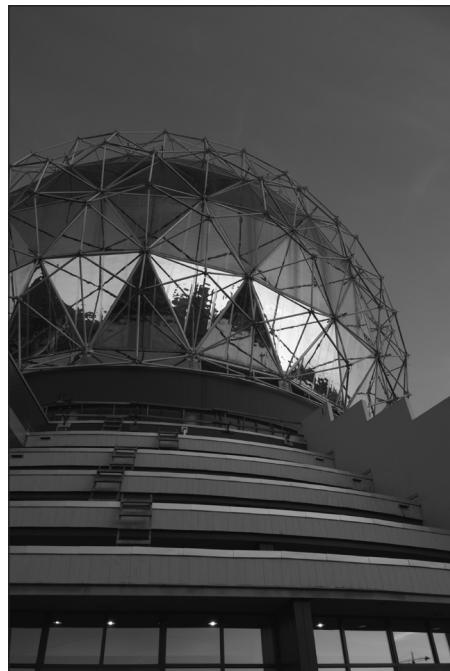


Photo of spider web by Martin Maun © 2010, Photo of rafters by John Leung © 2010, and Photo of Vancouver Science World by Lijuan Guo © 2010

There are countless examples of angles in nature, construction, art, and architecture. Have a look at the pictures above and see if you can find some adjacent, complementary, supplementary, and opposite angles.

Using Angle Relationships

In the following examples and activities you will apply the angle relationships you examined in the Explore. These angle relationships are:

- angles in a triangle
- adjacent angles
- complementary angles
- supplementary angles
- vertically opposite angles

Example 2


Photo by Mark Stout Photography © 2010

The photograph above shows an A-frame house. The roofline forms an isosceles triangle.

The angle at the top of the roof is 94° . The two angles at the base are equal. What is the measure of each?

Solution

The sum of the measures of the three angles of the triangle is 180° .

$$\begin{aligned}x + x + 94^\circ &= 180^\circ \\2x + 94^\circ &= 180^\circ \\2x &= 180^\circ - 94^\circ \\2x &= 66^\circ \\\frac{2x}{2} &= \frac{66^\circ}{2} \\x &= 33^\circ\end{aligned}$$

Each angle at the base of the triangle measure 33° .

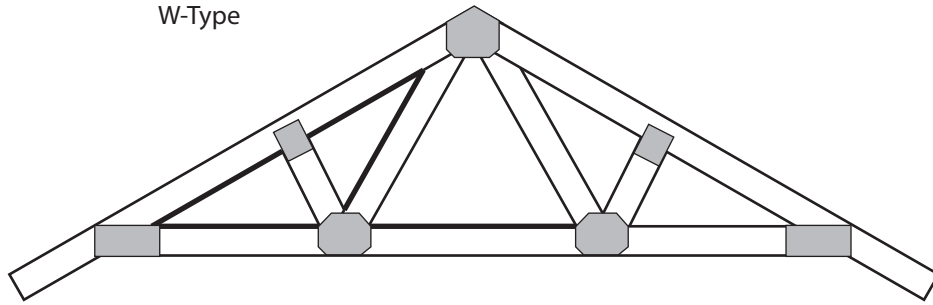
Example 3

The W-type roof truss is the most common type in simple wood-frame construction. This type of roof truss is shown in the following diagram. The angles we will examine are highlighted.

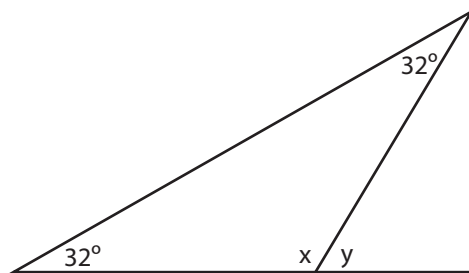
My Notes

My Notes

W-Type



The angles will depend on the pitch of the roof. If the pitch of the roof is 32° , calculate the values of x and y .



Solution

First find the value of x .

The sum of the angles in the triangle is 180° .

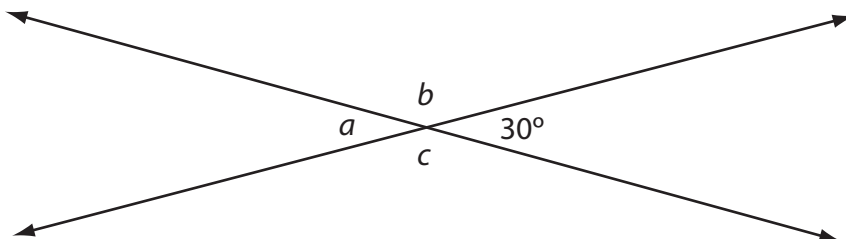
$$\begin{aligned} 32^\circ + 32^\circ + x &= 180^\circ \\ 64^\circ + x &= 180^\circ \\ x &= 180^\circ - 64^\circ \\ x &= 116^\circ \end{aligned}$$

The angles with measures x and y are supplementary.

$$\begin{aligned} x + y &= 180^\circ \\ 116^\circ + y &= 180^\circ \\ y &= 180^\circ - 116^\circ \\ y &= 64^\circ \end{aligned}$$

Example 4

Two straight paths cross at 30° as shown. Find the measures of the other three angles, which are represented by a , b , and c .


Solution

The angle with measure a is opposite the 30° . Therefore $a = 30^\circ$.

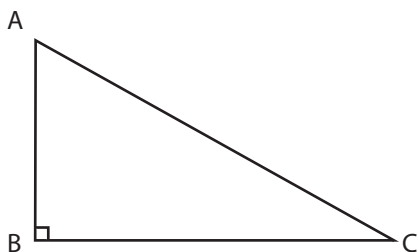
The angles with measures a and b are supplementary.

$$\begin{aligned} a + b &= 180^\circ \\ 30^\circ + b &= 180^\circ \\ b &= 180^\circ - 30^\circ \\ b &= 150^\circ \end{aligned}$$

The angle with measures c is opposite b . Therefore $c = b = 150^\circ$

Example 5

Angles A and C are angles of a right triangle.



Show that $\angle A$ and $\angle C$ are complementary.

My Notes

Solution

If angles A and C are complementary, they will add up to 90° . Start with what you know and see if you can show that angles A and C add up to 90° .

$$\angle A + \angle B + \angle C = 180^\circ$$

$$\angle A + 90^\circ + \angle C = 180^\circ$$

$$\angle A + 90^\circ + \angle C - 90^\circ = 180^\circ - 90^\circ$$

$$\angle A + \angle C = 90^\circ$$

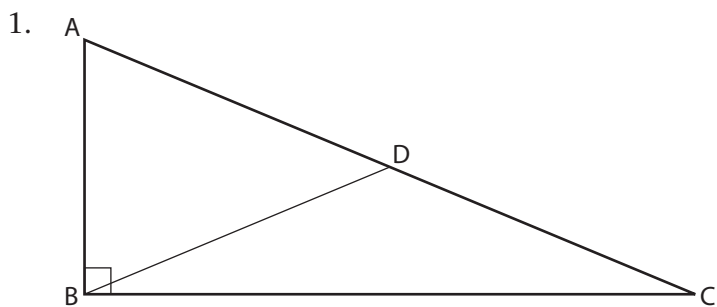
Subtract 90° from both sides of the equation.

Therefore angles A and C are complementary.

Activity 5 Self-Check

My Notes

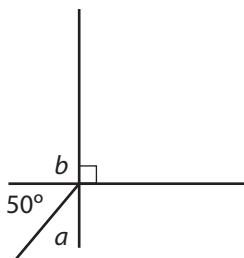
Complete the following questions. Please note: The diagrams may not be drawn to scale.



- a. Name two pairs of complementary angles.

- b. Name one pair of supplementary angles.

2. Calculate the angle measures a and b .



My Notes

3. Find the measures of a , b , c , and d for the rectangular envelope shown in the photograph. In the figure $b = c$.

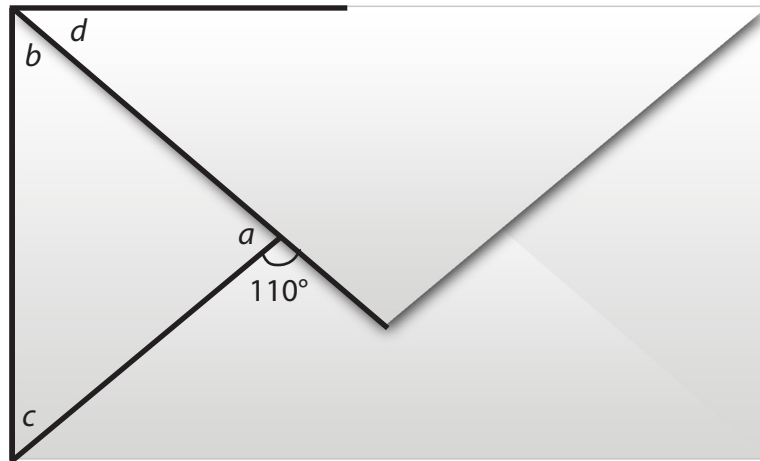
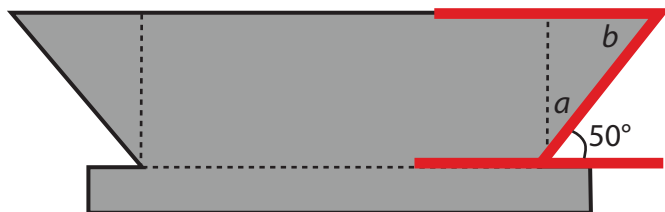
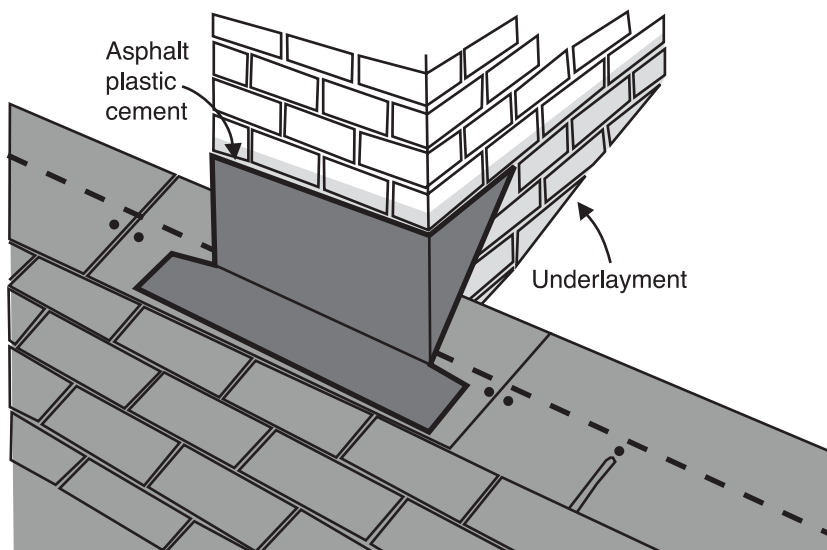


Photo by mayamaya © 2010

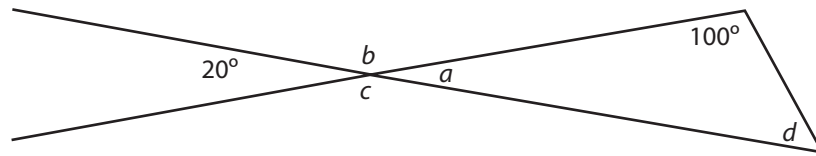
4. The layout for a sheet-metal front-cap flashing to be positioned at the front of a chimney is shown. Find the missing measures a and b .



My Notes

My Notes

5. Find the missing measures indicated in the diagram.

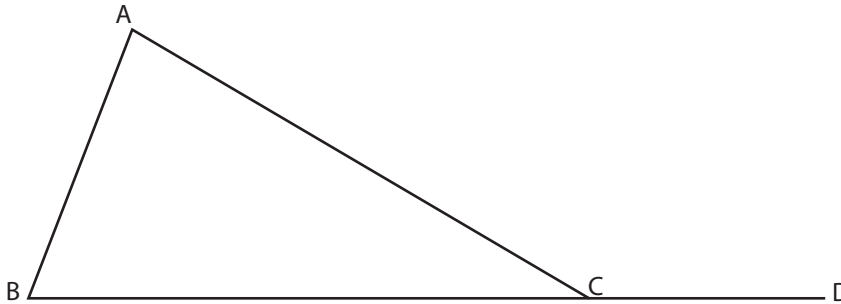


Turn to the solutions at the end of the section and mark your work.

Activity 6 Mastering Concepts

My Notes

- The angles within a triangle are called interior angles. If a side of a triangle is extended, it forms an exterior angle.

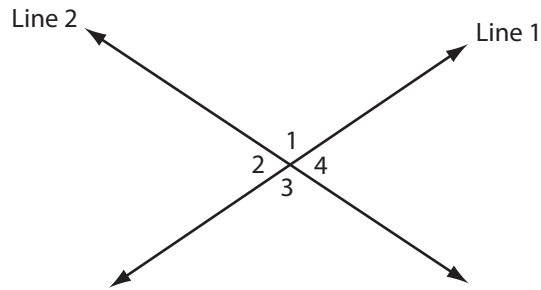


In $\triangle ABC$, $\angle A$, $\angle B$ and $\angle ACB$ are interior angles. $\angle ACD$ is an example of an exterior angle.

Show $\angle A + \angle B = \angle ACD$

My Notes

Use the diagram below to answer Question 2.



2. a. Complete the following statement. Then justify your answer.

$$\angle 1 + \angle 2 = \underline{\hspace{2cm}}^\circ.$$

b. Complete the following statement. Then justify your answer.

$$\angle 3 + \angle 2 = \underline{\hspace{2cm}}^\circ.$$

c. Using the results from (a) and (b), show (in a mathematical way) why $\angle 1 \cong \angle 3$.

d. Use a similar approach to show $\angle 2 \cong \angle 4$.



Turn to the solutions at the end of the section and mark your work.

Lesson Summary

My Notes



Photo by EDHAR © 2010 and Photo by Danylchenko Iaroslav © 2010

Many forms of art utilize the visual appeal of angles. A photographer looks for the best angle to shoot his or her subject and makes use of the lines and angles created by the subject and the background. The subjects of the photos you see here are dancers. Dance is another art form in which angles are of great importance. Dancers are always aware of the angles they are creating with their bodies. See how many angles you can trace in the photos above.

In this lesson you examined some relationships between sets of angles. You looked at the relationships between the angles in a triangle, adjacent angles, complementary angles, supplementary angles, and vertically opposite angles.

Lesson E

Parallel and Perpendicular Lines

To complete this lesson, you will need:

- several blank sheets of paper
- straightedge/ruler
- scissors
- protractor

In this lesson, you will complete:

- 5 activities

Essential Questions

- What relationships exist between angles formed when a line intersects a set of two parallel lines?
- How can the relationship among angles formed when a line intersects parallel lines be used to find missing angles in geometric shapes?

My Notes

Focus



Photo by Péter Gudella © 2010 and Photo by maigi © 2010

The photographs above involve very ordinary subjects. You might think that a photo of railroad tracks or a stack of two-by-fours would be boring, but these photos are certainly not that! So, what makes these images interesting?

In both photographs, the photographers have captured patterns formed by parallel and perpendicular lines.

In this lesson you'll investigate the angles formed when a line intersects a set of parallel lines. You'll also explore the relationships between those angles and apply the relationships to practical situations.

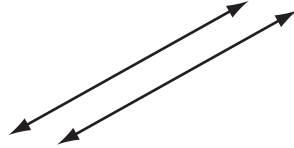
Get Started

You have probably studied **parallel** and **perpendicular** lines in previous courses. It is important that you understand the characteristics of parallel and perpendicular lines before you continue through this lesson.

My Notes

Parallel Lines

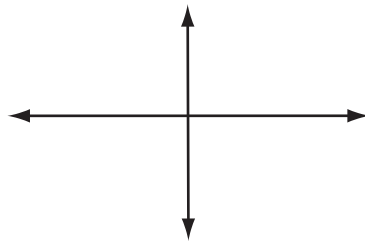
The diagram below shows two parallel lines.



What do you notice about the lines? What happens if you extend the lines in all directions? Do the lines intersect?

Perpendicular Lines

The diagram below shows two perpendicular lines.



What do you notice about the lines? Use your protractor to measure the angles formed by the intersection of the two lines.



To investigate parallel lines, go and look at *Parallel Lines* (<http://media.openschool.bc.ca/osbcmmedia/math/mathawm10/glossary/Division03/Parallel/index.html>). To investigate perpendicular lines, go and look at *Perpendicular Lines* (<http://media.openschool.bc.ca/osbcmmedia/math/mathawm10/glossary/Division03/Perpendicular/index.html>). Drag the lines around and read the resulting text. Rotate the lines by clicking on one of the dots and dragging and read the resulting text.

My Notes

Activity 1
Self-Check

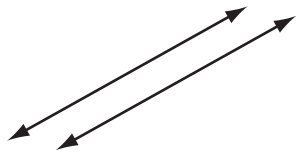
1. a. In your own words, explain what it means for two lines to be parallel.

b. In your own words, explain what it means for two lines to be perpendicular.

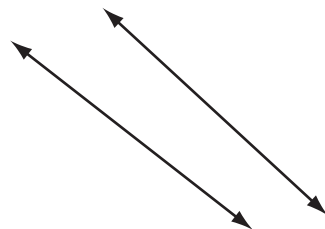
2. For each pair of lines below:
- i. state whether they are parallel, perpendicular, or neither parallel nor perpendicular.
 - ii. explain why your classification from part (i).

You may use a protractor and/or a straightedge.

a.

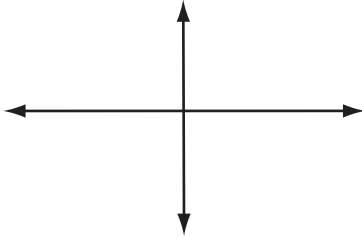


b.

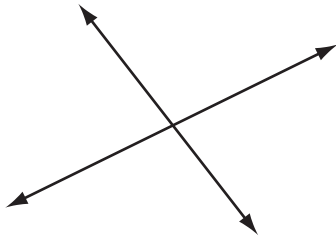


My Notes

c.



d.

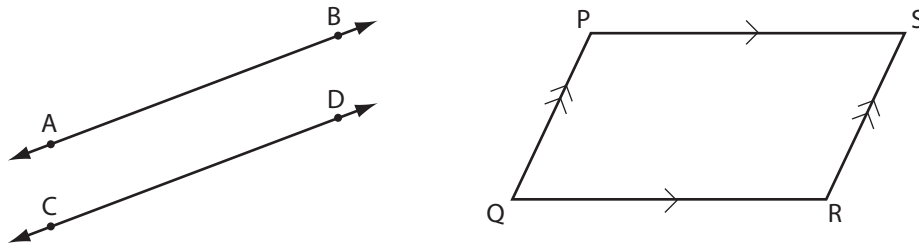




Turn to the solutions at the end of the section and mark your work.

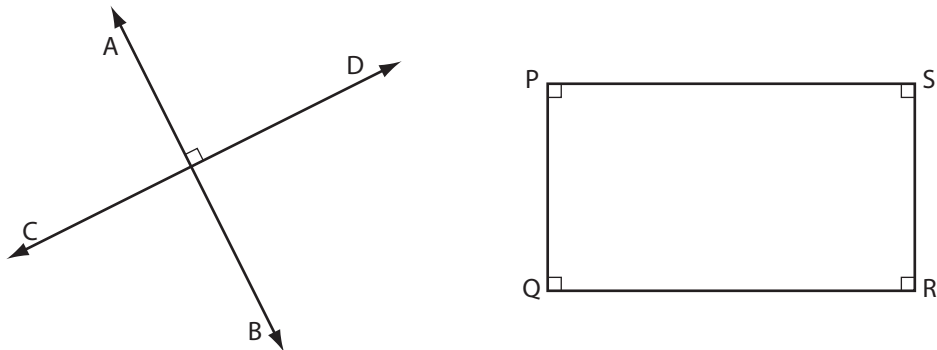
My Notes

Parallel and Perpendicular Line Notation



In the diagram above, line AB is parallel to line CD. The symbol \parallel means “is parallel to.” You may write $\overleftrightarrow{AB} \parallel \overleftrightarrow{CD}$. Note the symbol \leftrightarrow means “line.”

Also in the diagram above, the parallelogram PQRS, has some parallel sides. The small arrows on the sides of the parallelogram indicate this. The two sides that have a single arrow are parallel and the two sides that have double arrows are parallel. A side with a single arrow is not parallel to a side with double arrows. You can write: $\overline{PS} \parallel \overline{PQ}$ and $\overline{PQ} \parallel \overline{RS}$. The symbol $\overline{\quad}$ means “line segment”—a part of a line with definite endpoints.



In the diagram above, line AB is perpendicular to line CD. The symbol \perp means “is perpendicular to.” You could write $\overleftrightarrow{AB} \perp \overleftrightarrow{CD}$.

In the rectangle PQRS, $\overline{PS} \perp \overline{PQ}$, $\overline{PS} \perp \overline{RS}$, $\overline{PQ} \perp \overline{QR}$, and $\overline{SR} \perp \overline{QR}$.

My Notes

Parallel Planes

In the same way that lines can be parallel or perpendicular, planes can also be parallel or perpendicular. A plane is a flat, two-dimensional surface. You can think of it as a stiff sheet of paper or like a thin wall.

Consider the place where a wall meets a floor. We can think of the surfaces of the wall and the floor as two planes. What angle is created at the intersection of these two planes?



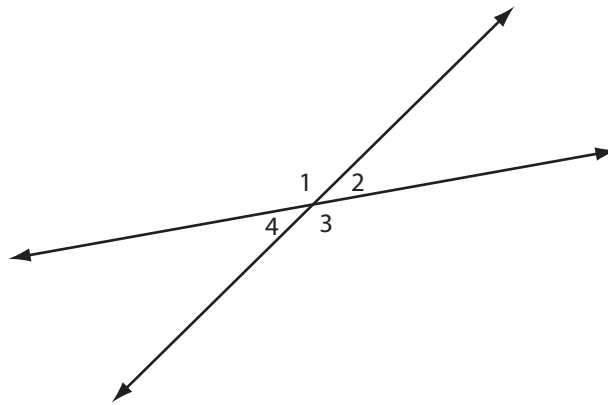
Photo by Sergey Shlyayev © 2010

A wall should meet the floor at a 90° angle. You can use a carpenter’s square (or a square from your geometry set) to check this using a wall in your house. Of course, buildings settle over time, and in many cases the walls won’t be perfectly perpendicular to the floor. Can you think of other examples of parallel or perpendicular planes?

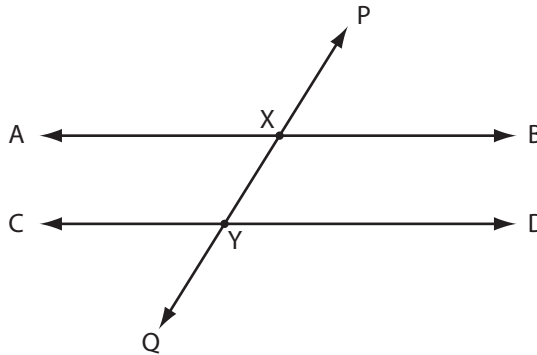
My Notes

Explore

In Lesson D you explored the relationships between pairs of angles. You looked at the angle relationships that result from the intersection of two lines, as shown below.



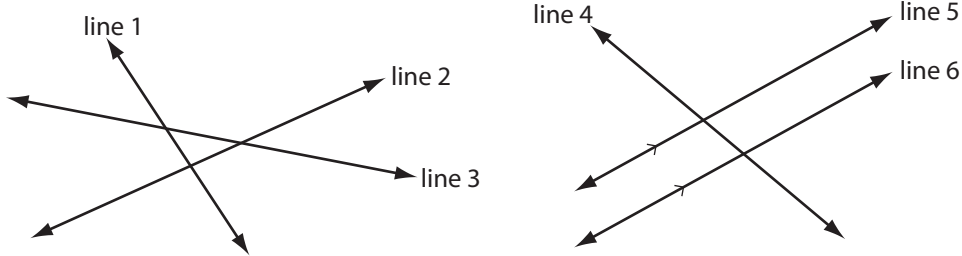
In the next activity lesson, you will explore the relationships among angles formed when two parallel lines are intersected by a third line.



In the diagram above, $\overleftrightarrow{AB} \parallel \overleftrightarrow{CD}$, and \overleftrightarrow{PQ} intersects the parallel lines at points X and Y. The intersecting line, \overleftrightarrow{PQ} , is called a **transversal**.

My Notes

By definition, a transversal is a line that crosses at least two other lines. Have a look at the diagram below. Can you identify which lines are transversals?

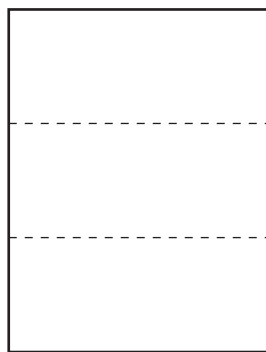


Lines 1, 2, 3 and 4 are transversals because each of them intersects two other lines. Lines 5 and 6 are not transversals because they each only intersect one other line.

Activity 2
Try This

In this activity, you will explore angles formed by a transversal. You will need a blank sheet of paper, a ruler or straightedge, and a pair of scissors.

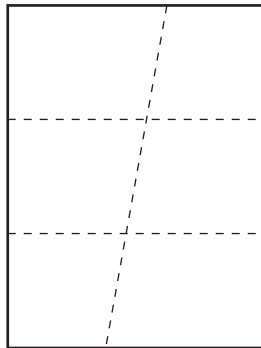
Step 1: Take a blank sheet of paper and fold it twice to form two parallel creases when unfolded.



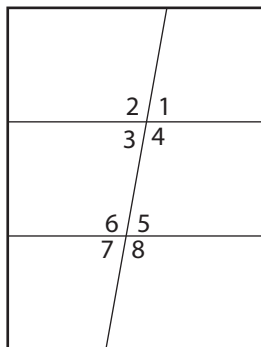
Step 2: Answer Question 1.

My Notes

Step 3: Fold the paper again. When unfolded the crease must cross both parallel creases.



Step 4: Using a ruler or other straightedge, draw lines on all the creases. Number the angles as shown below.



Step 5: Using scissors, cut along each of the lines. You should end up with six pieces that have numbers on them.

Step 6: Pick up $\angle 1$ and compare it to each of the other angles by placing it on top of each one. Are any of the angles congruent to (the same measure as) $\angle 1$? If there are, list those angles in the “Congruent to...” column in the following table.

Step 7: Repeat Step 5 for each of the other angles until you have compared them all. Please note: $\angle 3$ and $\angle 6$ are on the same piece of paper. $\angle 4$ and $\angle 5$ are also on the same piece of paper. Think about how you can compare $\angle 3$ with $\angle 6$ and $\angle 4$ with $\angle 5$. Question 2 will ask you to explain your strategy.

My Notes

Angle	Congruent to...
$\angle 1$	
$\angle 2$	
$\angle 3$	
$\angle 4$	
$\angle 5$	
$\angle 6$	
$\angle 7$	
$\angle 8$	

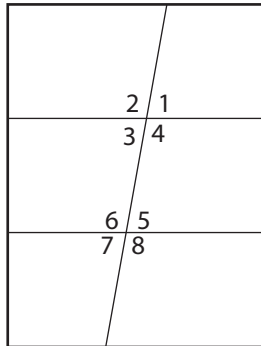
Questions

1. Explain how you folded the paper and why, when unfolded, the creases must be parallel.

2. $\angle 3$ and $\angle 6$ are on the same piece of paper. $\angle 4$ and $\angle 5$ are also on the same piece of paper. How did you compare $\angle 3$ with $\angle 6$ and $\angle 4$ with $\angle 5$?

My Notes

3. If you were to shade all congruent angles in the same colour, how many different colours would you need for this diagram. Explain your answer.



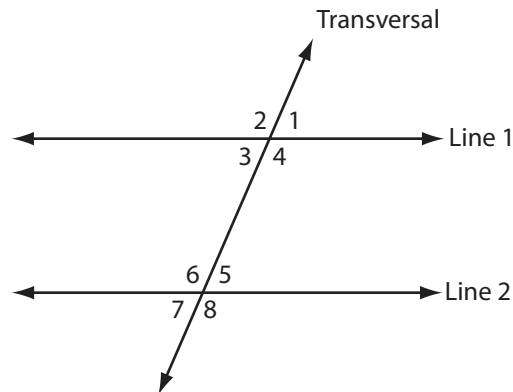


Turn to the solutions at the end of the section and mark your work.

Bringing Ideas Together

My Notes

In Explore, you compared the angles formed when two parallel lines are cut by a transversal.

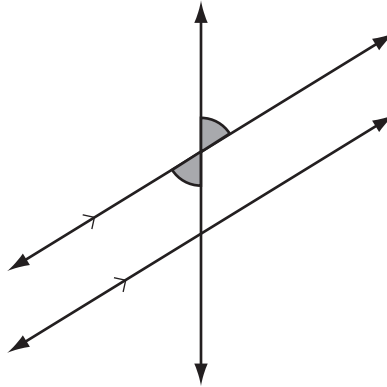


Now, we'll expand on what you found in Explore. We'll define several relationships between the angles formed when two parallel lines are cut by a transversal. We'll look at:

- vertically opposite angles
- corresponding angles
- alternate interior angles
- alternate exterior angles
- co-interior angles
- co-exterior angles

My Notes

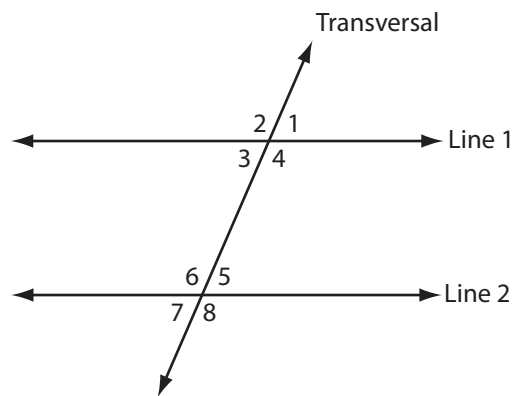
Vertically Opposite Angles



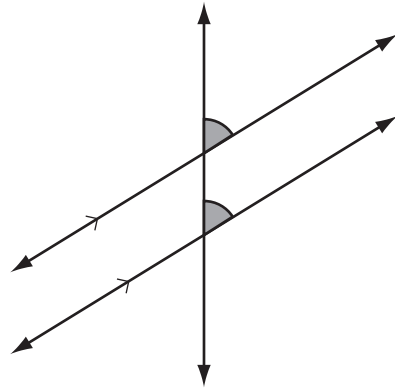
You should remember from Lesson D that **vertically opposite angles** are congruent. In Lesson D we only looked at the angles around a single intersection point. In Activity 2 in this lesson, you saw that the same rule applies when there is more than one intersection point.

In the diagram shown, there are four pairs of vertically opposite angles:

- $\angle 1$ and $\angle 3$
- $\angle 2$ and $\angle 4$
- $\angle 5$ and $\angle 7$
- $\angle 6$ and $\angle 8$



Corresponding Angles



In Activity 2, you discovered that angles in the same relative positions at the two points of intersection are congruent. These sets of congruent angles are called **corresponding angles**.

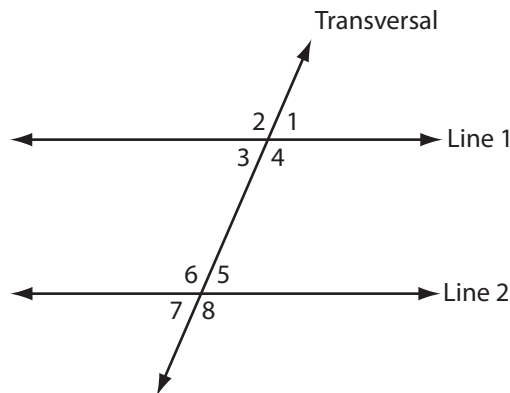
In the diagram shown, there are four pairs of corresponding angles:

$\angle 1$ and $\angle 5$

$\angle 2$ and $\angle 6$

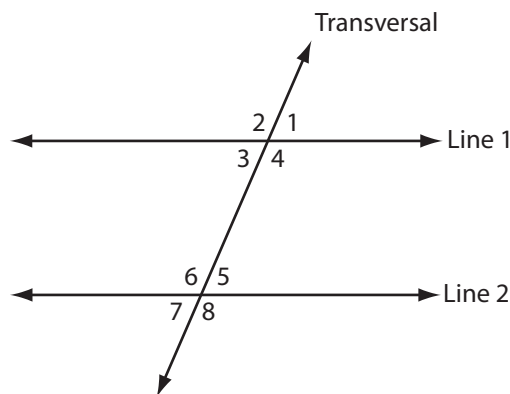
$\angle 3$ and $\angle 7$

$\angle 4$ and $\angle 8$



Interior and Exterior Angles

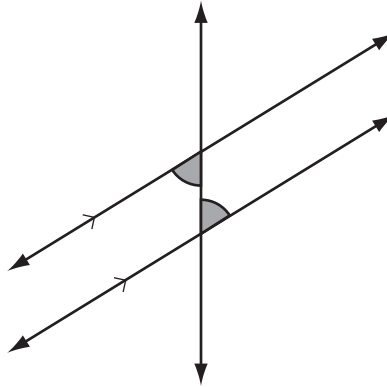
Look at the four angles between the parallel lines. $\angle 3$, $\angle 4$, $\angle 5$ and $\angle 6$ are termed **interior angles**. The other four angles ($\angle 1$, $\angle 2$, $\angle 7$, and $\angle 8$) are **exterior angles**.



My Notes

My Notes

Alternate Interior Angles



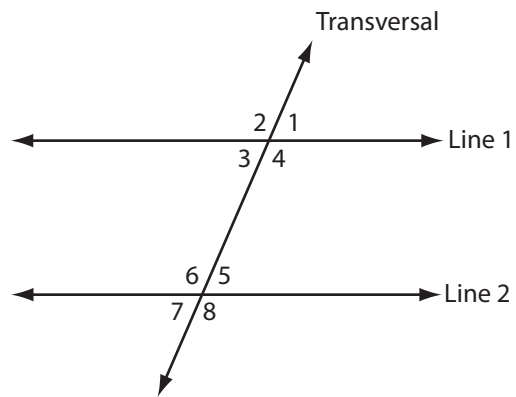
Do you remember from Activity 2, which interior angles are congruent?

The congruent pairs of interior angles are called alternate interior angles. The two angles in each pair of **alternate interior angles** lie on opposite sides of the transversal.

In the diagram shown, there are two pairs of alternate interior angles:

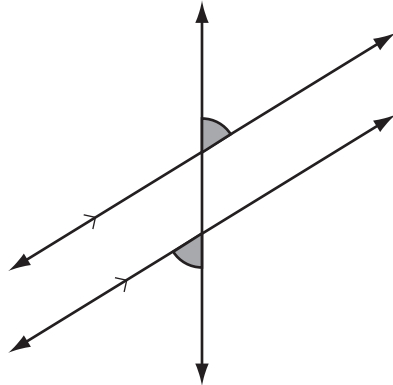
$\angle 3$ and $\angle 5$

$\angle 4$ and $\angle 6$



Alternate Exterior Angles

My Notes



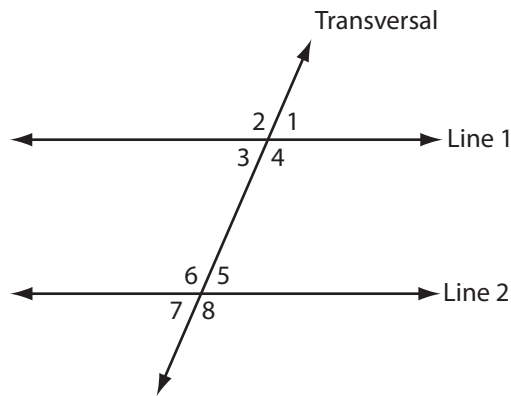
Do you remember from Activity 2, which exterior angles are congruent?

The congruent pairs of exterior angles are called **alternate exterior angles**. The two angles in each pair of alternate exterior angles lie on opposite sides of the transversal.

In the diagram shown, there are two pairs of alternate exterior angles:

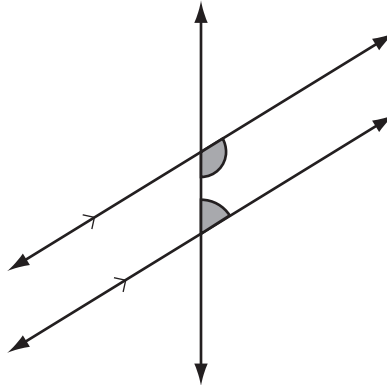
$\angle 1$ and $\angle 7$

$\angle 2$ and $\angle 8$



My Notes

Co-interior Angles



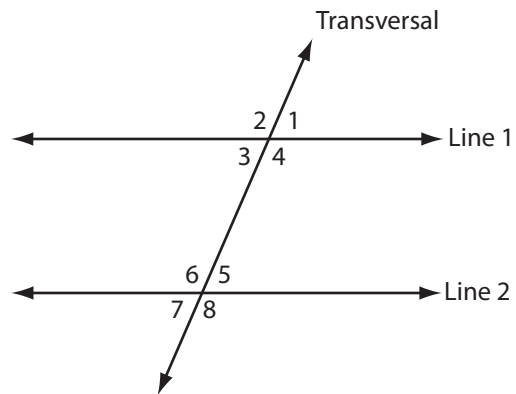
Co-interior angles are interior angles (angles that lie between the parallel lines) that are located on the same side of the transversal. Use your protractor to measure the co-interior angles in the diagram above. What do you notice?

The co-interior angles are supplementary—that is, their measures add up to 180° .

In the diagram shown, there are two pairs of co-interior angles:

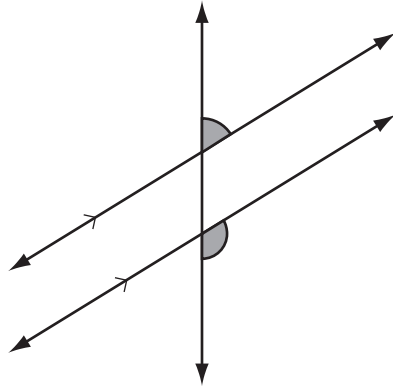
$\angle 3$ and $\angle 6$

$\angle 4$ and $\angle 5$



Co-exterior Angles

My Notes



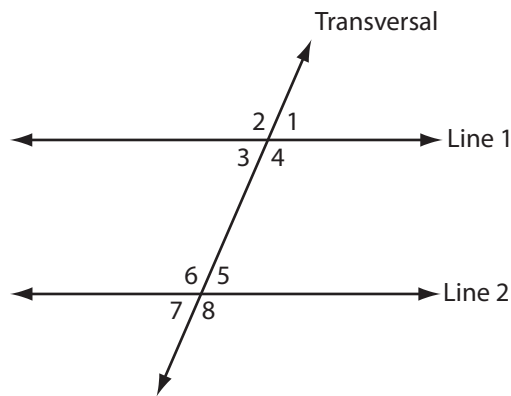
Co-exterior angles are exterior angles (angles that lie outside the parallel lines) that are located on the same side of the transversal. Use your protractor to measure the co-exterior angles in the diagram above. What do you notice?

Like co-interior angles, co-exterior angles are supplementary—that is, their measures add up to 180° .

In the diagram shown, there are two pairs of co-exterior angles:

$\angle 1$ and $\angle 8$

$\angle 2$ and $\angle 7$



My Notes

Summarizing Angle Relationships

You have learned about several angle relationships in this lesson:

- vertically opposite angles
- corresponding angles
- alternate interior angles
- alternate exterior angles
- co-interior angles
- co-exterior angles

To summarize what you learned, and solidify your understanding, explore the media *Angle Relationships* and then work through Activity 3.

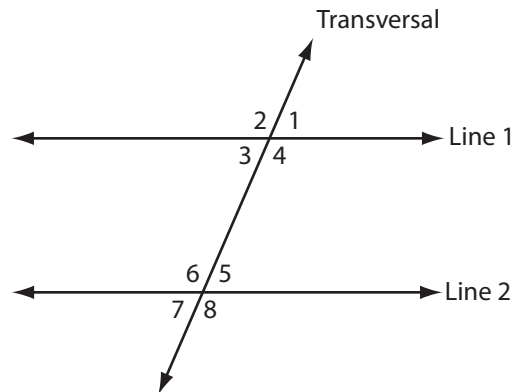


If you have Internet access and want further review before trying Activity 3, go and look at *Angle Relationships* (<http://media.openschool.bc.ca/osbcmmedia/math/mathawm10/glossary/Division03/Correspondingangles/index.html>) and select the angle relationship you'd like to review. Be sure to try out the applets! Move LINE 1 (the purple one) to change the angles formed at the intersection points. As you move the line, notice the relationships between the angles.

Activity 3 Self-Check

My Notes

1. Have a look at the diagram below.



Classify each angle pair below based on the angle relationships discussed in this lesson. Also, state whether the pair is congruent or supplementary.

Angle Pair	Angle Relationship	Congruent or Supplementary?
$\angle 1$ and $\angle 3$		
$\angle 4$ and $\angle 8$		
$\angle 4$ and $\angle 5$		
$\angle 3$ and $\angle 5$		
$\angle 2$ and $\angle 8$		
$\angle 2$ and $\angle 7$		

My Notes

2. a. Determine the missing angle measures in the diagram below.

$\angle 1 = \underline{\hspace{2cm}}$

$\angle 2 = \underline{\hspace{2cm}}$

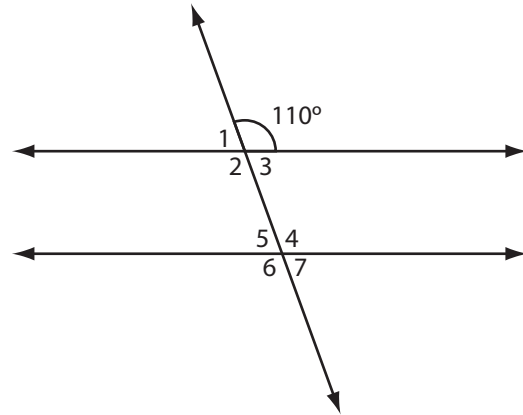
$\angle 3 = \underline{\hspace{2cm}}$

$\angle 4 = \underline{\hspace{2cm}}$


$\angle 5 = \underline{\hspace{2cm}}$

$\angle 6 = \underline{\hspace{2cm}}$

$\angle 7 = \underline{\hspace{2cm}}$



b. Explain how you determined the measures of $\angle 1$, $\angle 4$, and $\angle 7$.

 Turn to the solutions at the end of the section and mark your work.

Using Angle Relationships

Now that you're familiar with the relationships between the angles formed when two parallel lines are crossed by a transversal, let's look at how we can use these relationships to find missing angle measures.

My Notes

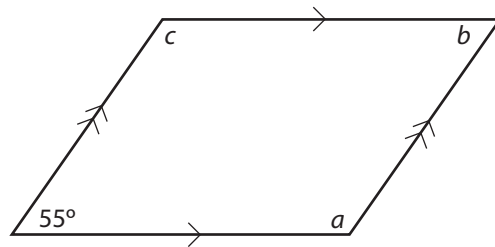
Before we look at the examples, you should note that all of the angle relationships work in the reverse direction. For example:

- If the corresponding angles are congruent, the lines are parallel.
- If the alternate interior or alternate exterior angles are equal, the lines are parallel.
- If the co-interior or co-exterior angles are supplementary the lines are parallel.

Now, work carefully through the examples and then complete Activity 4.

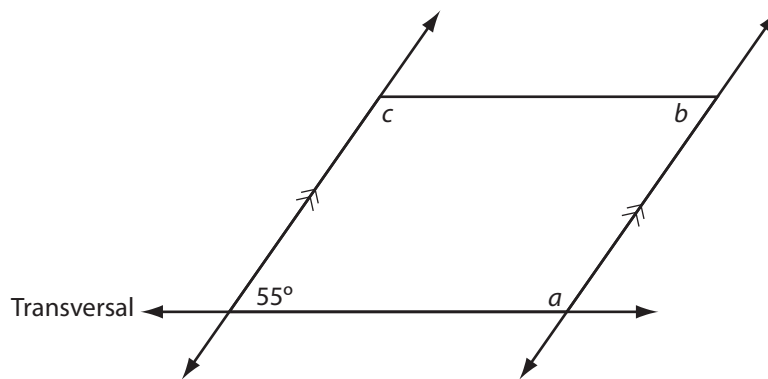
Example 1

Find the missing angle measures in the parallelogram below.



Solution

We can extend the lines of the parallelogram to make the angle relationships more apparent. To find angle measure a, the bottom of the parallelogram will be the transversal.



$$a + 55^\circ = 180^\circ$$

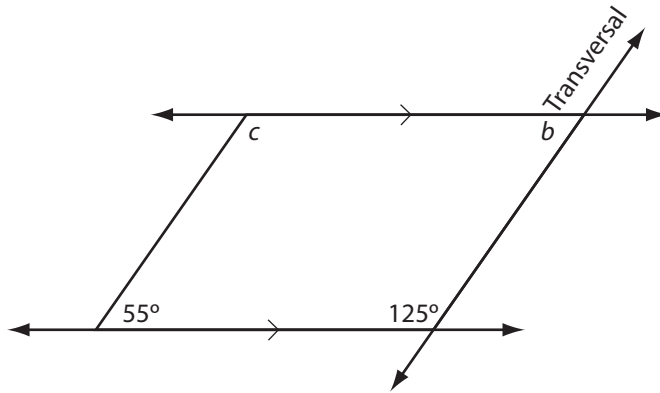
$$a = 180^\circ - 55^\circ$$

$$a = 125^\circ$$

co-interior angles

My Notes

Add angle measure a to your diagram. To find angle measure b , the right side of the parallelogram becomes the transversal.



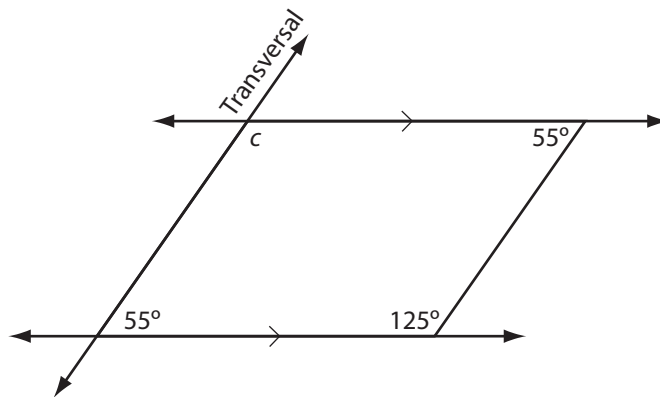
$$125^\circ + b = 180^\circ$$

$$b = 180^\circ - 125^\circ$$

$$b = 55^\circ$$

co-interior angles

Add angle measure b to your diagram. To find angle measure c , the left side of the parallelogram becomes the transversal.



$$c + 55^\circ = 180^\circ$$

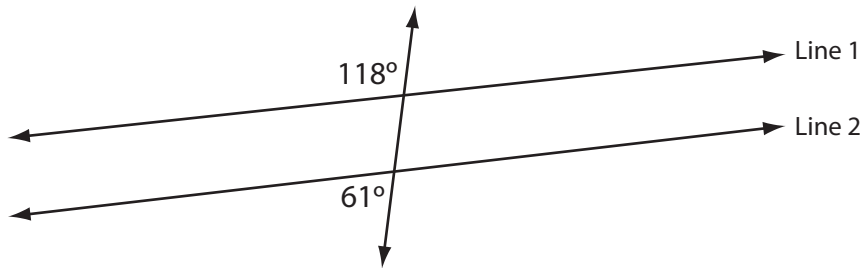
$$c = 180^\circ - 55^\circ$$

$$c = 125^\circ$$

co-interior angles

Example 2

Are lines 1 and 2 parallel? Why or why not?



Solution

The given angles are co-exterior angles.

If the lines were parallel, the co-exterior would be supplementary (add up to 180°).

But, $118^\circ + 61^\circ = 179^\circ$.

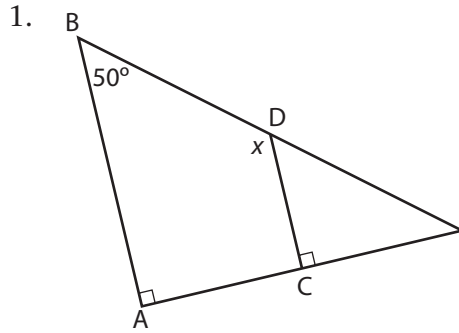
So, Line 1 and Line 2 are not parallel.

My Notes

My Notes

Activity 4
Self-Check

Please complete the following questions.

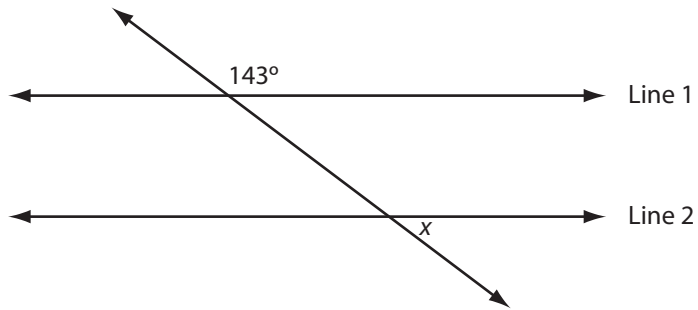


Based on the figure above, answer the following:

- a. Is $\overleftrightarrow{AB} \parallel \overleftrightarrow{CD}$? Justify your answer.

- b. Calculate the value of x . State the angle property you used to justify your answer.

2. Line 1 is parallel to Line 2.



Find the value of x .



Turn to the solutions at the end of the section and mark your work.

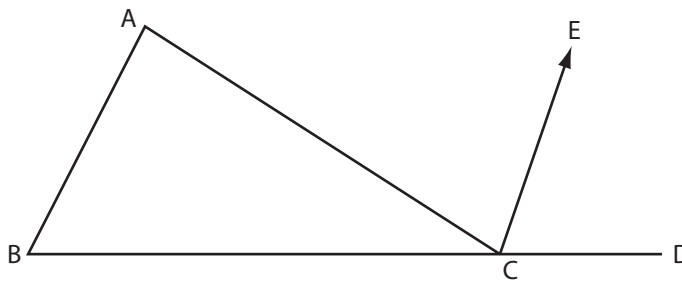
My Notes

My Notes

Activity 5 Mastering Concepts

The angles within a triangle are called **interior angles**. If a side of a triangle is extended, it forms an **exterior angle**.

In $\triangle ABC$ below, $\angle A$ and $\angle B$ are interior angles. $\angle ACD$ is an example of an exterior angle.



$\overleftrightarrow{AB} \parallel \overleftrightarrow{CE}$. Show that $\angle A + \angle B = \angle ACD$.



Turn to the solutions at the end of the section and mark your work.

Lesson Summary

My Notes

Optical illusions can be created by the careful placement and sizing of lines and colours on the page. Are the lines in the image below parallel to each other? How do you know?

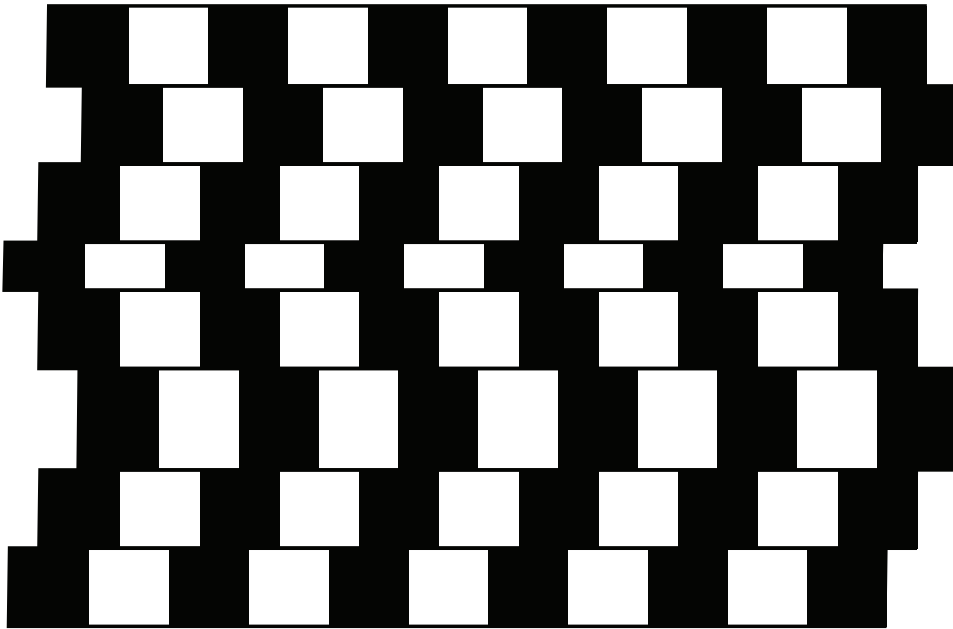


Photo by photazz © 2010

In this lesson you discovered that when two parallel lines are intersected by a transversal, corresponding angles, alternate interior, and alternate exterior angles are congruent. You also discovered that co-interior and co-exterior angles are supplementary. And if these relationships in a specific instance do not hold, then the lines simply are not parallel!

Lesson F

Solving Problems Using Angle Relationships

In this lesson, you will complete:

- 3 activities

Essential Questions

- How are the measures of angles determined in problem situations involving parallel lines and transversals?

My Notes

Focus

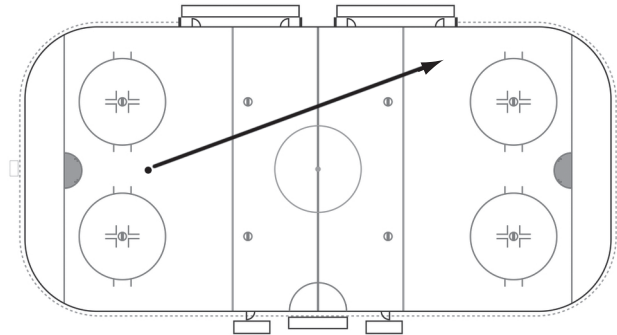


Photo by Jecowa © 2010

Whether or not you're a fan of hockey, you're probably familiar with the sight of an ice-hockey rink. Have you looked carefully at the markings on the ice? The markings consist of a series of circles, parallel, and perpendicular lines.

In the illustration above, a puck has travelled from the left side crossing both blue lines. The linesman's whistle blows and the signal for "offside" is given. If the puck travelled in a straight line, what can you say about the angles created at the two lines where the puck crossed?

Get Started

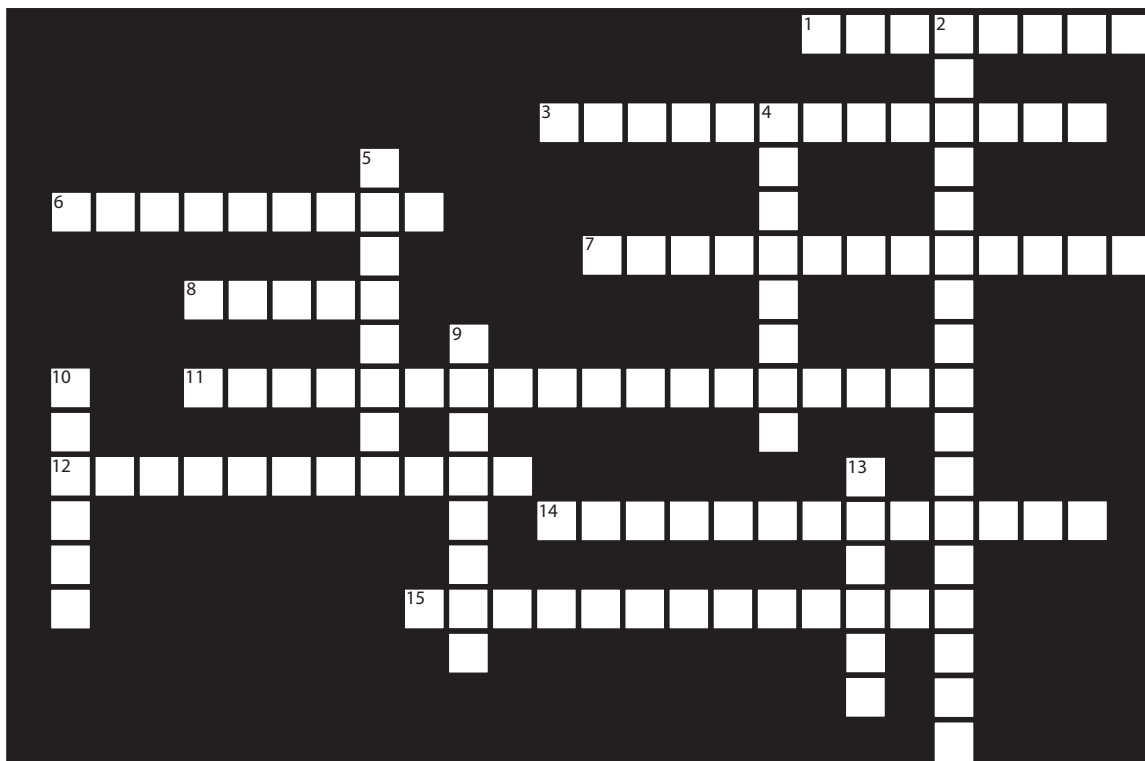
This lesson will be structured differently than usual. We will be solving problems involving angles formed when parallel lines are crossed by a transversal. Since you've already covered these relationships, we will omit the Explore portion of this lesson.

To start the lesson, complete Activity 1. You will review what you've learned in this section about angles and angle relationships.

When you've completed the activity, you will move directly to Bringing Ideas Together. There, we will work through several examples and you'll have a chance to apply the angle relationships you've learned.

Activity 1

Self-Check



Across

1. Angles which share a common vertex and lie on opposite sides of a common arm
3. Two angles with measures that add up to 90°
6. Angles with the same measure
7. Congruent angles in the same relative positions when two lines are intersected a transversal
8. An angle having a measure greater than 0° but less than 90°
11. Angles lying across from each other at the point where two lines intersect (2 words)
12. A line that cuts across two or more lines
14. Two angles with measures that add up to 180°
15. Lines that intersect at a 90° angle

Down

2. Interior angles lying on opposite sides of the transversal. One is on the left and the other is on the right. (2 words)
4. Angles outside two lines cut by a transversal
5. Angles lying between two lines cut by a transversal
9. Lines that never meet
10. An angle having a measure greater than 90° but less than 180°
13. An angle having a measure greater than 180° but less than 360°



Turn to the solutions at the end of the section and mark your work.

My Notes

Bringing Ideas Together

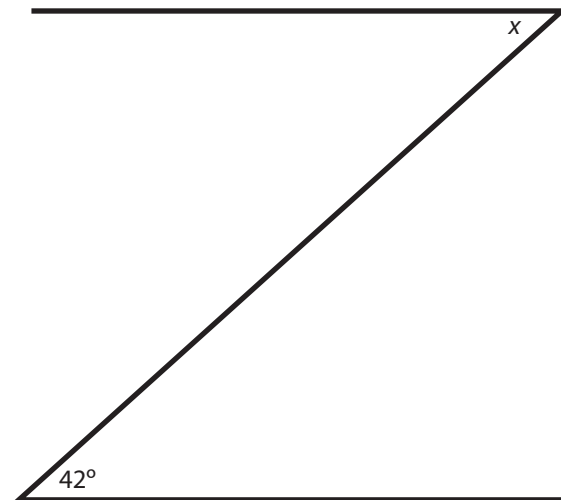
In the remaining portion of this lesson, we'll solve several problems that involve the angle relationships you've learned in this section.

As you work through the examples, think about what strategies you can use to help you solve problems that involve angle relationships. Also, make sure that you understand all of the angle relationships before you move on to Activity 2.

Example 1



Photo by Paul J. West © 2010

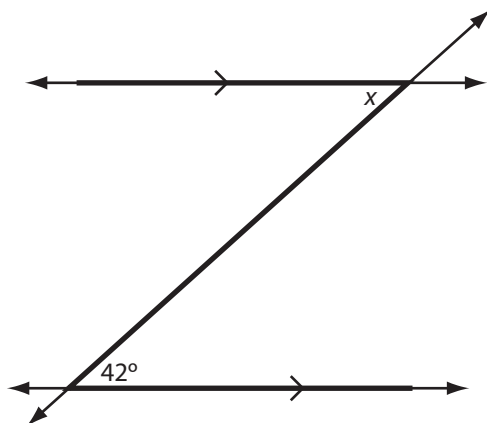


A wooden gate is cross-braced as shown. If the horizontal boards are parallel, determine the measure of angle between one of the cross braces and the top horizontal board.

Solution

The two angles in the “letter zed” are alternate interior angles. The diagonal cross brace is a “transversal” cutting across the “parallel lines” of the horizontal boards.

To make it easier to see these relationships, try extending the lines from the picture.

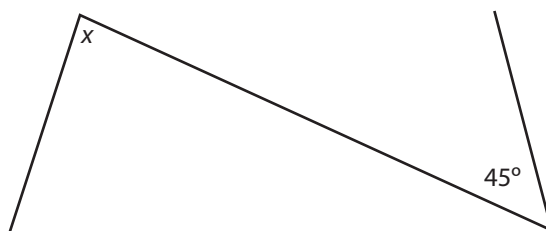


Alternate interior angles are congruent, so $x = 42^\circ$.

Example 2



Photo by Gulei Ivan © 2010



Classify the two angles in the diagram formed by the sides of the transmission tower and one of the diagonal braces. Do you have enough information to determine the value of x ? Why or why not?

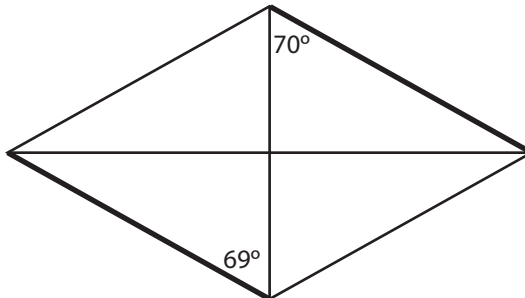
Solution

The angles in the “letter zed” are alternate interior angles. However, the sides of the tower are not parallel, so the angle relationships we have studied so not apply. There is not enough information to find the value of x .

My Notes

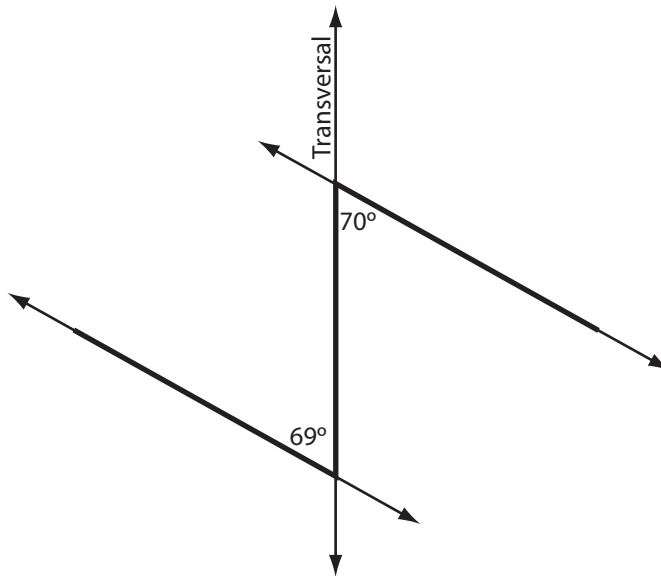
Example 3

The outline of a kite is shown below. Are the two bolded edges parallel? Justify your answer.



Solution

The 69° and 70° angles are alternate interior angles formed by the vertical transversal. Because these angles are not congruent, the two bold edges are not parallel.



If you'd like to view one more example, go and look at *Ladder Solution* (http://media.openschool.bc.ca/osbcmmedia/math/mathawm10/html/m10_3_m5_022/m10_3_m5_022.htm).

Problem-Solving Strategies

As you worked through the examples, what problem-solving strategies did you come up with?

You may have noticed that sometimes it can be difficult to see which angle relationship you can use to solve the problem. Drawing a diagram from the information given in the problem, and extending the lines in the diagram, can be very helpful strategies. In addition, you may also have your own strategies that help you remember the angle relationships.

Whatever strategies you find helpful, it's time to get them ready—you'll need them for the next activity!

My Notes

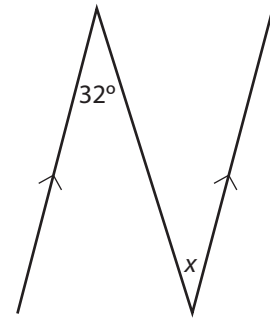
My Notes

Activity 2 Self-Check

1. This illustration shows a pair of vertical bridge supports and a cross-beam running from the top of one support to the base of the other. The angle between the second support and the beam is labelled x .



Photo by basel101658 © 2010



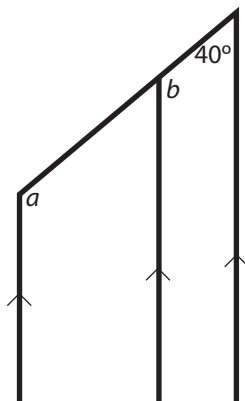
Calculate the value of x . Justify your answer. Assume the vertical bridge supports are parallel.

2. Find the missing angle measures for the windows of the chalet.

My Notes

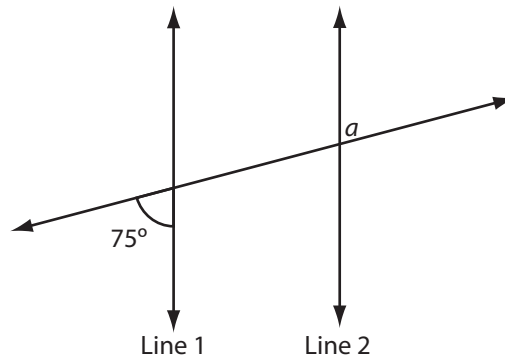


Photo by Mark Stout Photography © 2010

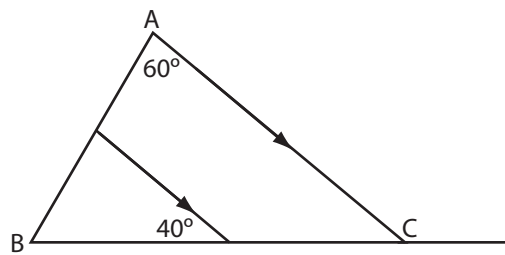


My Notes

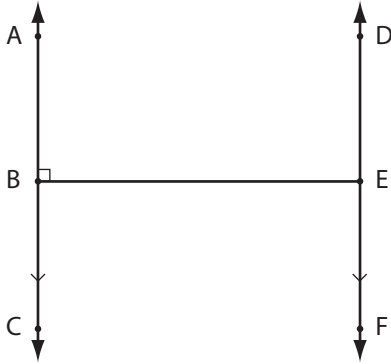
3. If Line 1 is parallel to Line 2, find a . What angle relationship did you use?



4. Find the measure of $\angle B$.



5. Have a look at the diagram below. Explain why $\overrightarrow{DF} \perp \overline{BE}$.



My Notes



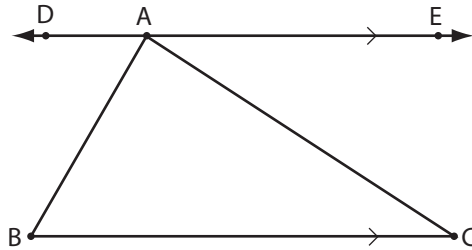
Turn to the solutions at the end of the section and mark your work.

My Notes

Activity 3

Mastering Concepts

A line, \overleftrightarrow{DE} is drawn through point A, parallel to the base of $\triangle ABC$. This is shown in the diagram below. Without using a protractor, prove that the three angles of $\triangle ABC$ add up to 180° .



Turn to the solutions at the end of the section and mark your work.

Lesson Summary

My Notes

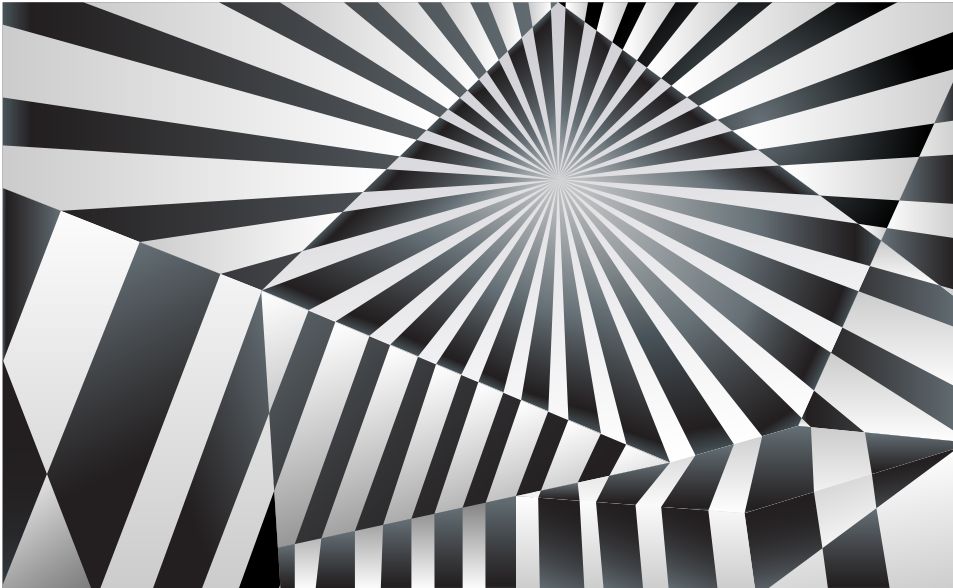


Photo by Amid © 2010

In this image, the abstract background of light and dark incorporates parallel and convergent lines. Can you identify lines and angles formed by transversals?

My Notes

Did You Know?

At the turn of the Twentieth Century, there were movements away from painting pictures which, some argued, could just as well be taken with a camera. One of those movements was cubism. Cubist paintings are not from one perspective. They show objects broken up and re-configured in an abstract form. Often, the surfaces and parts of objects intersect at a variety of angles. You can find out more about cubism through an Internet search.

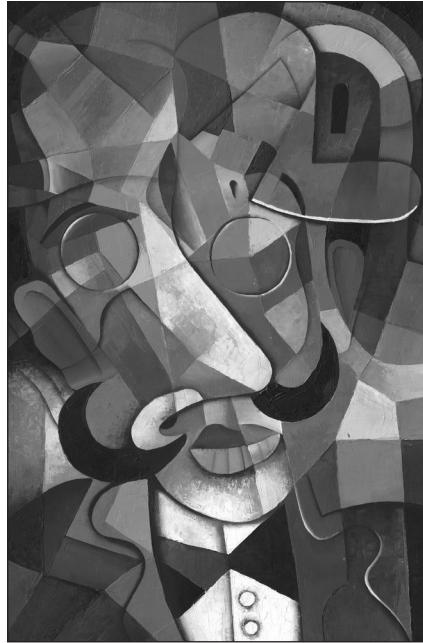


Photo by Eugene Ivanov © 2010



Try typing *cubism*, *modern art*, or *Picasso* into an Internet search engine like Google or Yahoo.



In this lesson you practised your skills at solving problems that involve angles created by the intersection of transversals with parallel lines. These problems involved vertically opposite angles, adjacent and supplementary angles, corresponding angles, alternate angles, and co-interior and co-exterior angles.

Angles— Appendix

Data Pages	183
Solutions	191
Glossary	209
Grid Paper	217

TABLE OF CONVERSIONS

1 inch	≈	2.54 centimetres
1 foot	≈	30.5 centimetres
1 foot	≈	0.305 metres
1 foot	=	12 inches
1 yard	=	3 feet
1 yard	≈	0.915 metres
1 mile	=	1760 yards
1 mile	≈	1.6 kilometres
1 kilogram	≈	2.2 pounds
1 litre	≈	1.06 US quarts
1 litre	≈	0.26 US gallons
1 gallon	≈	4 quarts
1 British gallon	≈	$\frac{6}{5}$ US gallon

FORMULAE
Temperature

$$C = \frac{5}{9}(F - 32)$$

Trigonometry

(Put your calculator in Degree Mode)

- Right triangles

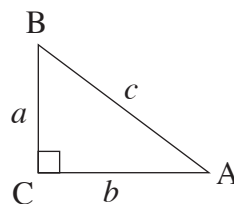
Pythagorean Theorem

$$a^2 + b^2 = c^2$$

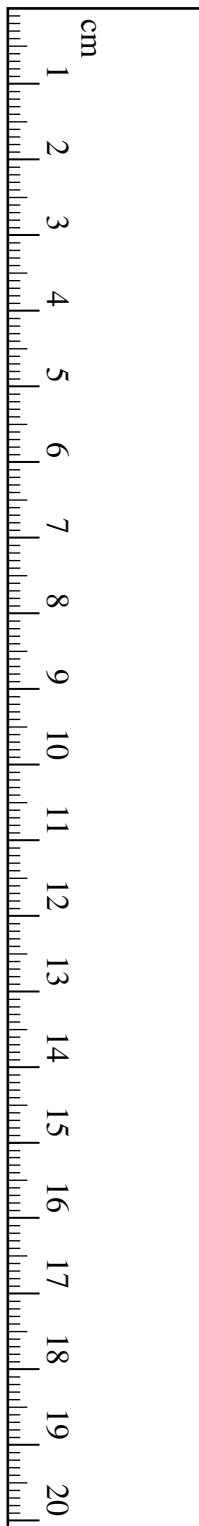
$$\sin A = \frac{\text{opposite}}{\text{hypotenuse}}$$

$$\cos A = \frac{\text{adjacent}}{\text{hypotenuse}}$$

$$\tan A = \frac{\text{opposite}}{\text{adjacent}}$$



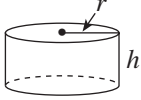
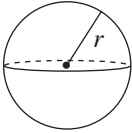
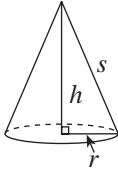
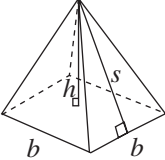
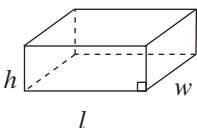
GEOMETRIC FORMULAE

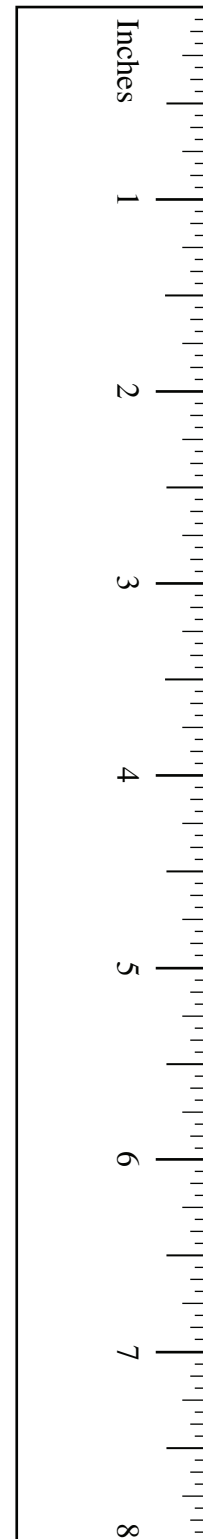


Key Legend	
l = length	P = perimeter
w = width	C = circumference
b = base	A = area
h = height	SA = surface area
s = slant height	V = volume
r = radius	
d = diameter	

Geometric Figure	Perimeter	Area
Rectangle 	$P = 2l + 2w$ or $P = 2(l + w)$	$A = lw$
Triangle 	$P = a + b + c$	$A = \frac{bh}{2}$
Circle 	$C = \pi d$ or $C = 2\pi r$	$A = \pi r^2$

Note: Use the value of π programmed in your calculator rather than the approximation of 3.14.

Geometric Figure	Surface Area
Cylinder 	$A_{top} = \pi r^2$ $A_{base} = \pi r^2$ $A_{side} = 2\pi rh$ $SA = 2\pi r^2 + 2\pi rh$
Sphere 	$SA = 4\pi r^2$ <p>or</p> $SA = \pi d^2$
Cone 	$A_{side} = \pi rs$ $A_{base} = \pi r^2$ $SA = \pi r^2 + \pi rs$
Square-Based Pyramid 	$A_{triangle} = \frac{1}{2}bs$ (for each triangle) $A_{base} = b^2$ $SA = 2bs + b^2$
Rectangular Prism 	$SA = wh + wh + lw + lw + lh + lh$ <p>or</p> $SA = 2(wh + lw + lh)$
General Right Prism	$SA =$ the sum of the areas of all the faces
General Pyramid	$SA =$ the sum of the areas of all the faces



Note: Use the value of π programmed in your calculator rather than the approximation of 3.14.

**Canada Pension Plan Contributions
Weekly (52 pay periods a year)**

**Cotisations au Régime de pensions du Canada
Hebdomadaire (52 périodes de paie par année)**

Pay Rémunération		CPP RPC	Pay Rémunération		CPP RPC	Pay Rémunération		CPP RPC	Pay Rémunération		CPP RPC
From - De	To - À		From - De	To - À		From - De	To - À		From - De	To - À	
358.11	- 358.31	14.40	372.66	- 372.85	15.12	387.20	- 387.40	15.84	401.75	- 401.94	16.56
358.32	- 358.51	14.41	372.86	- 373.05	15.13	387.41	- 387.60	15.85	401.95	- 402.14	16.57
358.52	- 358.71	14.42	373.06	- 373.25	15.14	387.61	- 387.80	15.86	402.15	- 402.35	16.58
358.72	- 358.91	14.43	373.26	- 373.46	15.15	387.81	- 388.00	15.87	402.36	- 402.55	16.59
358.92	- 359.11	14.44	373.47	- 373.66	15.16	388.01	- 388.20	15.88	402.56	- 402.75	16.60
359.12	- 359.32	14.45	373.67	- 373.86	15.17	388.21	- 388.41	15.89	402.76	- 402.95	16.61
359.33	- 359.52	14.46	373.87	- 374.06	15.18	388.42	- 388.61	15.90	402.96	- 403.15	16.62
359.53	- 359.72	14.47	374.07	- 374.26	15.19	388.62	- 388.81	15.91	403.16	- 403.36	16.63
359.73	- 359.92	14.48	374.27	- 374.47	15.20	388.82	- 389.01	15.92	403.37	- 403.56	16.64
359.93	- 360.12	14.49	374.48	- 374.67	15.21	389.02	- 389.21	15.93	403.57	- 403.76	16.65
360.13	- 360.33	14.50	374.68	- 374.87	15.22	389.22	- 389.42	15.94	403.77	- 403.96	16.66
360.34	- 360.53	14.51	374.88	- 375.07	15.23	389.43	- 389.62	15.95	403.97	- 404.16	16.67
360.54	- 360.73	14.52	375.08	- 375.27	15.24	389.63	- 389.82	15.96	404.17	- 404.37	16.68
360.74	- 360.93	14.53	375.28	- 375.48	15.25	389.83	- 390.02	15.97	404.38	- 404.57	16.69
360.94	- 361.13	14.54	375.49	- 375.68	15.26	390.03	- 390.22	15.98	404.58	- 404.77	16.70
361.14	- 361.34	14.55	375.69	- 375.88	15.27	390.23	- 390.43	15.99	404.78	- 404.97	16.71
361.35	- 361.54	14.56	375.89	- 376.08	15.28	390.44	- 390.63	16.00	404.98	- 405.17	16.72
361.55	- 361.74	14.57	376.09	- 376.28	15.29	390.64	- 390.83	16.01	405.18	- 405.38	16.73
361.75	- 361.94	14.58	376.29	- 376.49	15.30	390.84	- 391.03	16.02	405.39	- 405.58	16.74
361.95	- 362.14	14.59	376.50	- 376.69	15.31	391.04	- 391.23	16.03	405.59	- 405.78	16.75
362.15	- 362.35	14.60	376.70	- 376.89	15.32	391.24	- 391.44	16.04	405.79	- 405.98	16.76
362.36	- 362.55	14.61	376.90	- 377.09	15.33	391.45	- 391.64	16.05	405.99	- 406.18	16.77
362.56	- 362.75	14.62	377.10	- 377.29	15.34	391.65	- 391.84	16.06	406.19	- 406.39	16.78
362.76	- 362.95	14.63	377.30	- 377.50	15.35	391.85	- 392.04	16.07	406.40	- 406.59	16.79
362.96	- 363.15	14.64	377.51	- 377.70	15.36	392.05	- 392.24	16.08	406.60	- 406.79	16.80
363.16	- 363.36	14.65	377.71	- 377.90	15.37	392.25	- 392.45	16.09	406.80	- 406.99	16.81
363.37	- 363.56	14.66	377.91	- 378.10	15.38	392.46	- 392.65	16.10	407.00	- 407.19	16.82
363.57	- 363.76	14.67	378.11	- 378.31	15.39	392.66	- 392.85	16.11	407.20	- 407.40	16.83
363.77	- 363.96	14.68	378.32	- 378.51	15.40	392.86	- 393.05	16.12	407.41	- 407.60	16.84
363.97	- 364.16	14.69	378.52	- 378.71	15.41	393.06	- 393.25	16.13	407.61	- 407.80	16.85
364.17	- 364.37	14.70	378.72	- 378.91	15.42	393.26	- 393.46	16.14	407.81	- 408.00	16.86
364.38	- 364.57	14.71	378.92	- 379.11	15.43	393.47	- 393.66	16.15	408.01	- 408.20	16.87
364.58	- 364.77	14.72	379.12	- 379.32	15.44	393.67	- 393.86	16.16	408.21	- 408.41	16.88
364.78	- 364.97	14.73	379.33	- 379.52	15.45	393.87	- 394.06	16.17	408.42	- 408.61	16.89
364.98	- 365.17	14.74	379.53	- 379.72	15.46	394.07	- 394.26	16.18	408.62	- 408.81	16.90
365.18	- 365.38	14.75	379.73	- 379.92	15.47	394.27	- 394.47	16.19	408.82	- 409.01	16.91
365.39	- 365.58	14.76	379.93	- 380.12	15.48	394.48	- 394.67	16.20	409.02	- 409.21	16.92
365.59	- 365.78	14.77	380.13	- 380.33	15.49	394.68	- 394.87	16.21	409.22	- 409.42	16.93
365.79	- 365.98	14.78	380.34	- 380.53	15.50	394.88	- 395.07	16.22	409.43	- 409.62	16.94
365.99	- 366.18	14.79	380.54	- 380.73	15.51	395.08	- 395.27	16.23	409.63	- 409.82	16.95
366.19	- 366.39	14.80	380.74	- 380.93	15.52	395.28	- 395.48	16.24	409.83	- 410.02	16.96
366.40	- 366.59	14.81	380.94	- 381.13	15.53	395.49	- 395.68	16.25	410.03	- 410.22	16.97
366.60	- 366.79	14.82	381.14	- 381.34	15.54	395.69	- 395.88	16.26	410.23	- 410.43	16.98
366.80	- 366.99	14.83	381.35	- 381.54	15.55	395.89	- 396.08	16.27	410.44	- 410.63	16.99
367.00	- 367.19	14.84	381.55	- 381.74	15.56	396.09	- 396.28	16.28	410.64	- 410.83	17.00
367.20	- 367.40	14.85	381.75	- 381.94	15.57	396.29	- 396.49	16.29	410.84	- 411.03	17.01
367.41	- 367.60	14.86	381.95	- 382.14	15.58	396.50	- 396.69	16.30	411.04	- 411.23	17.02
367.61	- 367.80	14.87	382.15	- 382.35	15.59	396.70	- 396.89	16.31	411.24	- 411.44	17.03
367.81	- 368.00	14.88	382.36	- 382.55	15.60	396.90	- 397.09	16.32	411.45	- 411.64	17.04
368.01	- 368.20	14.89	382.56	- 382.75	15.61	397.10	- 397.29	16.33	411.65	- 411.84	17.05
368.21	- 368.41	14.90	382.76	- 382.95	15.62	397.30	- 397.50	16.34	411.85	- 412.04	17.06
368.42	- 368.61	14.91	382.96	- 383.15	15.63	397.51	- 397.70	16.35	412.05	- 412.24	17.07
368.62	- 368.81	14.92	383.16	- 383.36	15.64	397.71	- 397.90	16.36	412.25	- 412.45	17.08
368.82	- 369.01	14.93	383.37	- 383.56	15.65	397.91	- 398.10	16.37	412.46	- 412.65	17.09
369.02	- 369.21	14.94	383.57	- 383.76	15.66	398.11	- 398.31	16.38	412.66	- 412.85	17.10
369.22	- 369.42	14.95	383.77	- 383.96	15.67	398.32	- 398.51	16.39	412.86	- 413.05	17.11
369.43	- 369.62	14.96	383.97	- 384.16	15.68	398.52	- 398.71	16.40	413.06	- 413.25	17.12
369.63	- 369.82	14.97	384.17	- 384.37	15.69	398.72	- 398.91	16.41	413.26	- 413.46	17.13
369.83	- 370.02	14.98	384.38	- 384.57	15.70	398.92	- 399.11	16.42	413.47	- 413.66	17.14
370.03	- 370.22	14.99	384.58	- 384.77	15.71	399.12	- 399.32	16.43	413.67	- 413.86	17.15
370.23	- 370.43	15.00	384.78	- 384.97	15.72	399.33	- 399.52	16.44	413.87	- 414.06	17.16
370.44	- 370.63	15.01	384.98	- 385.17	15.73	399.53	- 399.72	16.45	414.07	- 414.26	17.17
370.64	- 370.83	15.02	385.18	- 385.38	15.74	399.73	- 399.92	16.46	414.27	- 414.47	17.18
370.84	- 371.03	15.03	385.39	- 385.58	15.75	399.93	- 400.12	16.47	414.48	- 414.67	17.19
371.04	- 371.23	15.04	385.59	- 385.78	15.76	400.13	- 400.33	16.48	414.68	- 414.87	17.20
371.24	- 371.44	15.05	385.79	- 385.98	15.77	400.34	- 400.53	16.49	414.88	- 415.07	17.21
371.45	- 371.64	15.06	385.99	- 386.18	15.78	400.54	- 400.73	16.50	415.08	- 415.27	17.22
371.65	- 371.84	15.07	386.19	- 386.39	15.79	400.74	- 400.93	16.51	415.28	- 415.48	17.23
371.85	- 372.04	15.08	386.40	- 386.59	15.80	400.94	- 401.13	16.52	415.49	- 415.68	17.24
372.05	- 372.24	15.09	386.60	- 386.79	15.81	401.14	- 401.34	16.53	415.69	- 415.88	17.25
372.25	- 372.45	15.10	386.80	- 386.99	15.82	401.35	- 401.54	16.54	415.89	- 416.08	17.26
372.46	- 372.65	15.11	387.00	- 387.19	15.83	401.55	- 401.74	16.55	416.09	- 416.28	17.27

Employee's maximum CPP contribution for the year 2009 is \$2,118.60

B-6

La cotisation maximale de l'employé au RPC pour l'année 2009 est de 2 118,60 \$

Employment Insurance Premiums

Cotisations à l'assurance-emploi

Insurable Earnings Rémunération assurable		El premium Cotisation d'AE	Insurable Earnings Rémunération assurable		El premium Cotisation d'AE	Insurable Earnings Rémunération assurable		El premium Cotisation d'AE	Insurable Earnings Rémunération assurable		El premium Cotisation d'AE
From - De	To - À		From - De	To - À		From - De	To - À		From - De	To - À	
333.24	- 333.81	5.77	374.86	- 375.43	6.49	416.48	- 417.05	7.21	458.10	- 458.67	7.93
333.82	- 334.39	5.78	375.44	- 376.01	6.50	417.06	- 417.63	7.22	458.68	- 459.24	7.94
334.40	- 334.97	5.79	376.02	- 376.58	6.51	417.64	- 418.20	7.23	459.25	- 459.82	7.95
334.98	- 335.54	5.80	376.59	- 377.16	6.52	418.21	- 418.78	7.24	459.83	- 460.40	7.96
335.55	- 336.12	5.81	377.17	- 377.74	6.53	418.79	- 419.36	7.25	460.41	- 460.98	7.97
336.13	- 336.70	5.82	377.75	- 378.32	6.54	419.37	- 419.94	7.26	460.99	- 461.56	7.98
336.71	- 337.28	5.83	378.33	- 378.90	6.55	419.95	- 420.52	7.27	461.57	- 462.13	7.99
337.29	- 337.86	5.84	378.91	- 379.47	6.56	420.53	- 421.09	7.28	462.14	- 462.71	8.00
337.87	- 338.43	5.85	379.48	- 380.05	6.57	421.10	- 421.67	7.29	462.72	- 463.29	8.01
338.44	- 339.01	5.86	380.06	- 380.63	6.58	421.68	- 422.25	7.30	463.30	- 463.87	8.02
339.02	- 339.59	5.87	380.64	- 381.21	6.59	422.26	- 422.83	7.31	463.88	- 464.45	8.03
339.60	- 340.17	5.88	381.22	- 381.79	6.60	422.84	- 423.41	7.32	464.46	- 465.02	8.04
340.18	- 340.75	5.89	381.80	- 382.36	6.61	423.42	- 423.98	7.33	465.03	- 465.60	8.05
340.76	- 341.32	5.90	382.37	- 382.94	6.62	423.99	- 424.56	7.34	465.61	- 466.18	8.06
341.33	- 341.90	5.91	382.95	- 383.52	6.63	424.57	- 425.14	7.35	466.19	- 466.76	8.07
341.91	- 342.48	5.92	383.53	- 384.10	6.64	425.15	- 425.72	7.36	466.77	- 467.34	8.08
342.49	- 343.06	5.93	384.11	- 384.68	6.65	425.73	- 426.30	7.37	467.35	- 467.91	8.09
343.07	- 343.64	5.94	384.69	- 385.26	6.66	426.31	- 426.87	7.38	467.92	- 468.49	8.10
343.65	- 344.21	5.95	385.27	- 385.83	6.67	426.88	- 427.45	7.39	468.50	- 469.07	8.11
344.22	- 344.79	5.96	385.84	- 386.41	6.68	427.46	- 428.03	7.40	469.08	- 469.65	8.12
344.80	- 345.37	5.97	386.42	- 386.99	6.69	428.04	- 428.61	7.41	469.66	- 470.23	8.13
345.38	- 345.95	5.98	387.00	- 387.57	6.70	428.62	- 429.19	7.42	470.24	- 470.80	8.14
345.96	- 346.53	5.99	387.58	- 388.15	6.71	429.20	- 429.76	7.43	470.81	- 471.38	8.15
346.54	- 347.10	6.00	388.16	- 388.72	6.72	429.77	- 430.34	7.44	471.39	- 471.96	8.16
347.11	- 347.68	6.01	388.73	- 389.30	6.73	430.35	- 430.92	7.45	471.97	- 472.54	8.17
347.69	- 348.26	6.02	389.31	- 389.88	6.74	430.93	- 431.50	7.46	472.55	- 473.12	8.18
348.27	- 348.84	6.03	389.89	- 390.46	6.75	431.51	- 432.08	7.47	473.13	- 473.69	8.19
348.85	- 349.42	6.04	390.47	- 391.04	6.76	432.09	- 432.65	7.48	473.70	- 474.27	8.20
349.43	- 349.99	6.05	391.05	- 391.61	6.77	432.66	- 433.23	7.49	474.28	- 474.85	8.21
350.00	- 350.57	6.06	391.62	- 392.19	6.78	433.24	- 433.81	7.50	474.86	- 475.43	8.22
350.58	- 351.15	6.07	392.20	- 392.77	6.79	433.82	- 434.39	7.51	475.44	- 476.01	8.23
351.16	- 351.73	6.08	392.78	- 393.35	6.80	434.40	- 434.97	7.52	476.02	- 476.58	8.24
351.74	- 352.31	6.09	393.36	- 393.93	6.81	434.98	- 435.54	7.53	476.59	- 477.16	8.25
352.32	- 352.89	6.10	393.94	- 394.50	6.82	435.55	- 436.12	7.54	477.17	- 477.74	8.26
352.90	- 353.46	6.11	394.51	- 395.08	6.83	436.13	- 436.70	7.55	477.75	- 478.32	8.27
353.47	- 354.04	6.12	395.09	- 395.66	6.84	436.71	- 437.28	7.56	478.33	- 478.90	8.28
354.05	- 354.62	6.13	395.67	- 396.24	6.85	437.29	- 437.86	7.57	478.91	- 479.47	8.29
354.63	- 355.20	6.14	396.25	- 396.82	6.86	437.87	- 438.43	7.58	479.48	- 480.05	8.30
355.21	- 355.78	6.15	396.83	- 397.39	6.87	438.44	- 439.01	7.59	480.06	- 480.63	8.31
355.79	- 356.35	6.16	397.40	- 397.97	6.88	439.02	- 439.59	7.60	480.64	- 481.21	8.32
356.36	- 356.93	6.17	397.98	- 398.55	6.89	439.60	- 440.17	7.61	481.22	- 481.79	8.33
356.94	- 357.51	6.18	398.56	- 399.13	6.90	440.18	- 440.75	7.62	481.80	- 482.36	8.34
357.52	- 358.09	6.19	399.14	- 399.71	6.91	440.76	- 441.32	7.63	482.37	- 482.94	8.35
358.10	- 358.67	6.20	399.72	- 400.28	6.92	441.33	- 441.90	7.64	482.95	- 483.52	8.36
358.68	- 359.24	6.21	400.29	- 400.86	6.93	441.91	- 442.48	7.65	483.53	- 484.10	8.37
359.25	- 359.82	6.22	400.87	- 401.44	6.94	442.49	- 443.06	7.66	484.11	- 484.68	8.38
359.83	- 360.40	6.23	401.45	- 402.02	6.95	443.07	- 443.64	7.67	484.69	- 485.26	8.39
360.41	- 360.98	6.24	402.03	- 402.60	6.96	443.65	- 444.21	7.68	485.27	- 485.83	8.40
360.99	- 361.56	6.25	402.61	- 403.17	6.97	444.22	- 444.79	7.69	485.84	- 486.41	8.41
361.57	- 362.13	6.26	403.18	- 403.75	6.98	444.80	- 445.37	7.70	486.42	- 486.99	8.42
362.14	- 362.71	6.27	403.76	- 404.33	6.99	445.38	- 445.95	7.71	487.00	- 487.57	8.43
362.72	- 363.29	6.28	404.34	- 404.91	7.00	445.96	- 446.53	7.72	487.58	- 488.15	8.44
363.30	- 363.87	6.29	404.92	- 405.49	7.01	446.54	- 447.10	7.73	488.16	- 488.72	8.45
363.88	- 364.45	6.30	405.50	- 406.06	7.02	447.11	- 447.68	7.74	488.73	- 489.30	8.46
364.46	- 365.02	6.31	406.07	- 406.64	7.03	447.69	- 448.26	7.75	489.31	- 489.88	8.47
365.03	- 365.60	6.32	406.65	- 407.22	7.04	448.27	- 448.84	7.76	489.89	- 490.46	8.48
365.61	- 366.18	6.33	407.23	- 407.80	7.05	448.85	- 449.42	7.77	490.47	- 491.04	8.49
366.19	- 366.76	6.34	407.81	- 408.38	7.06	449.43	- 449.99	7.78	491.05	- 491.61	8.50
366.77	- 367.34	6.35	408.39	- 408.95	7.07	450.00	- 450.57	7.79	491.62	- 492.19	8.51
367.35	- 367.91	6.36	408.96	- 409.53	7.08	450.58	- 451.15	7.80	492.20	- 492.77	8.52
367.92	- 368.49	6.37	409.54	- 410.11	7.09	451.16	- 451.73	7.81	492.78	- 493.35	8.53
368.50	- 369.07	6.38	410.12	- 410.69	7.10	451.74	- 452.31	7.82	493.36	- 493.93	8.54
369.08	- 369.65	6.39	410.70	- 411.27	7.11	452.32	- 452.89	7.83	493.94	- 494.50	8.55
369.66	- 370.23	6.40	411.28	- 411.84	7.12	452.90	- 453.46	7.84	494.51	- 495.08	8.56
370.24	- 370.80	6.41	411.85	- 412.42	7.13	453.47	- 454.04	7.85	495.09	- 495.66	8.57
370.81	- 371.38	6.42	412.43	- 413.00	7.14	454.05	- 454.62	7.86	495.67	- 496.24	8.58
371.39	- 371.96	6.43	413.01	- 413.58	7.15	454.63	- 455.20	7.87	496.25	- 496.82	8.59
371.97	- 372.54	6.44	413.59	- 414.16	7.16	455.21	- 455.78	7.88	496.83	- 497.39	8.60
372.55	- 373.12	6.45	414.17	- 414.73	7.17	455.79	- 456.35	7.89	497.40	- 497.97	8.61
373.13	- 373.69	6.46	414.74	- 415.31	7.18	456.36	- 456.93	7.90	497.98	- 498.55	8.62
373.70	- 374.27	6.47	415.32	- 415.89	7.19	456.94	- 457.51	7.91	498.56	- 499.13	8.63
374.28	- 374.85	6.48	415.90	- 416.47	7.20	457.52	- 458.09	7.92	499.14	- 499.71	8.64

Yearly maximum insurable earnings are \$42,300
 Yearly maximum employee premiums are \$731.79
 The premium rate for 2009 is 1.73 %

Le maximum annuel de la rémunération assurable est de 42 300 \$
 La cotisation maximale annuelle de l'employé est de 731,79 \$
 Le taux de cotisation pour 2009 est de 1,73 %

Federal tax deductions
 Effective January 1, 2009
 Weekly (52 pay periods a year)
 Also look up the tax deductions
 in the provincial table

Retenues d'impôt fédéral
 En vigueur le 1^{er} janvier 2009
 Hebdomadaire (52 périodes de paie par année)
 Cherchez aussi les retenues d'impôt
 dans la table provinciale

Pay Rémunération	Federal claim codes/Codes de demande fédéraux										
	0	1	2	3	4	5	6	7	8	9	10
From Less than De Moins de	Deduct from each pay Retenez sur chaque paie										
335 - 339	44.65	15.55	12.70	7.00	1.30						
339 - 343	45.20	16.10	13.25	7.55	1.85						
343 - 347	45.80	16.65	13.80	8.10	2.45						
347 - 351	46.35	17.20	14.35	8.65	3.00						
351 - 355	46.90	17.75	14.90	9.25	3.55						
355 - 359	47.45	18.35	15.50	9.80	4.10						
359 - 363	48.00	18.90	16.05	10.35	4.65						
363 - 367	48.60	19.45	16.60	10.90	5.25						
367 - 371	49.15	20.00	17.15	11.45	5.80	.10					
371 - 375	49.70	20.55	17.70	12.05	6.35	.65					
375 - 379	50.25	21.15	18.30	12.60	6.90	1.20					
379 - 383	50.80	21.70	18.85	13.15	7.45	1.80					
383 - 387	51.40	22.25	19.40	13.70	8.00	2.35					
387 - 391	51.95	22.80	19.95	14.25	8.60	2.90					
391 - 395	52.50	23.35	20.50	14.85	9.15	3.45					
395 - 399	53.05	23.95	21.10	15.40	9.70	4.00					
399 - 403	53.60	24.50	21.65	15.95	10.25	4.60					
403 - 407	54.20	25.05	22.20	16.50	10.80	5.15					
407 - 411	54.75	25.60	22.75	17.05	11.40	5.70					
411 - 415	55.30	26.15	23.30	17.65	11.95	6.25	.55				
415 - 419	55.85	26.75	23.90	18.20	12.50	6.80	1.15				
419 - 423	56.40	27.30	24.45	18.75	13.05	7.40	1.70				
423 - 427	57.00	27.85	25.00	19.30	13.60	7.95	2.25				
427 - 431	57.55	28.40	25.55	19.85	14.20	8.50	2.80				
431 - 435	58.10	28.95	26.10	20.45	14.75	9.05	3.35				
435 - 439	58.65	29.50	26.70	21.00	15.30	9.60	3.95				
439 - 443	59.20	30.10	27.25	21.55	15.85	10.20	4.50				
443 - 447	59.80	30.65	27.80	22.10	16.40	10.75	5.05				
447 - 451	60.35	31.20	28.35	22.65	17.00	11.30	5.60				
451 - 455	60.90	31.75	28.90	23.25	17.55	11.85	6.15	.50			
455 - 459	61.45	32.30	29.50	23.80	18.10	12.40	6.75	1.05			
459 - 463	62.00	32.90	30.05	24.35	18.65	12.95	7.30	1.60			
463 - 467	62.60	33.45	30.60	24.90	19.20	13.55	7.85	2.15			
467 - 471	63.15	34.00	31.15	25.45	19.80	14.10	8.40	2.70			
471 - 475	63.70	34.55	31.70	26.05	20.35	14.65	8.95	3.30			
475 - 479	64.25	35.10	32.30	26.60	20.90	15.20	9.55	3.85			
479 - 483	64.80	35.70	32.85	27.15	21.45	15.75	10.10	4.40			
483 - 487	65.40	36.25	33.40	27.70	22.00	16.35	10.65	4.95			
487 - 491	65.95	36.80	33.95	28.25	22.60	16.90	11.20	5.50			
491 - 495	66.50	37.35	34.50	28.85	23.15	17.45	11.75	6.10	.40		
495 - 499	67.05	37.90	35.10	29.40	23.70	18.00	12.35	6.65	.95		
499 - 503	67.60	38.50	35.65	29.95	24.25	18.55	12.90	7.20	1.50		
503 - 507	68.20	39.05	36.20	30.50	24.80	19.15	13.45	7.75	2.05		
507 - 511	68.75	39.60	36.75	31.05	25.40	19.70	14.00	8.30	2.65		
511 - 515	69.30	40.15	37.30	31.65	25.95	20.25	14.55	8.90	3.20		
515 - 519	69.85	40.70	37.90	32.20	26.50	20.80	15.15	9.45	3.75		
519 - 523	70.40	41.30	38.45	32.75	27.05	21.35	15.70	10.00	4.30		
523 - 527	71.00	41.85	39.00	33.30	27.60	21.95	16.25	10.55	4.85		
527 - 531	71.55	42.40	39.55	33.85	28.20	22.50	16.80	11.10	5.45		
531 - 535	72.10	42.95	40.10	34.45	28.75	23.05	17.35	11.70	6.00	.30	
535 - 539	72.65	43.50	40.70	35.00	29.30	23.60	17.90	12.25	6.55	.85	
539 - 543	73.20	44.10	41.25	35.55	29.85	24.15	18.50	12.80	7.10	1.40	
543 - 547	73.80	44.65	41.80	36.10	30.40	24.75	19.05	13.35	7.65	2.00	
547 - 551	74.35	45.20	42.35	36.65	31.00	25.30	19.60	13.90	8.25	2.55	
551 - 555	74.90	45.75	42.90	37.25	31.55	25.85	20.15	14.50	8.80	3.10	

British Columbia provincial tax deductions
Effective January 1, 2009
Weekly (52 pay periods a year)
Also look up the tax deductions
in the federal table

Retenues d'impôt provincial de la Colombie-Britannique
En vigueur le 1^{er} janvier 2009
Hebdomadaire (52 périodes de paie par année)
Cherchez aussi les retenues d'impôt
dans la table fédérale

Pay Rémunération		Provincial claim codes/Codes de demande provinciaux													
		0	1	2	3	4	5	6	7	8	9	10			
From De	Less than Moins de	Deduct from each pay Retenez sur chaque paie													
343		*	.00												<p>*You normally use claim code "0" only for non-resident employees. However, if you have non-resident employees who earn less than the minimum amount shown in the "Pay" column, you may not be able to use these tables. Instead, refer to the "Step-by-step calculation of tax deductions" in Section "A" of this publication.</p> <p>*Le code de demande «0» est normalement utilisé seulement pour les non-résidents. Cependant, si la rémunération de votre employé non résidant est inférieure au montant minimum indiqué dans la colonne «Rémunération», vous ne pourrez peut-être pas utiliser ces tables. Reportez-vous alors au «Calcul des retenues d'impôt, étape par étape» dans la section «A» de cette publication.</p>
343 - 345		9.30	.20												
345 - 347		9.45	.35												
347 - 349		9.60	.50												
349 - 351		9.80	.65												
351 - 353		9.95	.80												
353 - 355		10.10	.95												
355 - 357		10.25	1.15	.10											
357 - 359		10.40	1.30	.25											
359 - 361		10.55	1.45	.40											
361 - 363		10.75	1.60	.60											
363 - 365		10.90	1.75	.75											
365 - 367		11.05	1.90	.90											
367 - 369		11.20	2.10	1.05											
369 - 371		11.35	2.25	1.20											
371 - 373		11.50	2.40	1.35											
373 - 375		11.70	2.55	1.55											
375 - 377		11.85	2.70	1.70											
377 - 379		12.00	2.90	1.85											
379 - 381		12.15	3.05	2.00											
381 - 383		12.30	3.20	2.15	.10										
383 - 385		12.45	3.35	2.30	.25										
385 - 387		12.65	3.50	2.50	.45										
387 - 389		12.80	3.65	2.65	.60										
389 - 391		12.95	3.85	2.80	.75										
391 - 393		13.10	4.00	2.95	.90										
393 - 395		13.25	4.15	3.10	1.05										
395 - 397		13.40	4.30	3.30	1.20										
397 - 399		13.60	4.45	3.45	1.40										
399 - 401		13.75	4.60	3.60	1.55										
401 - 403		13.90	4.80	3.75	1.70										
403 - 405		14.05	4.95	3.90	1.85										
405 - 407		14.20	5.10	4.05	2.00										
407 - 409		14.35	5.25	4.25	2.15	.10									
409 - 411		14.55	5.40	4.40	2.35	.30									
411 - 413		14.70	5.55	4.55	2.50	.45									
413 - 415		14.85	5.75	4.70	2.65	.60									
415 - 417		15.00	5.90	4.85	2.80	.75									
417 - 419		15.15	6.05	5.00	2.95	.90									
419 - 421		15.30	6.20	5.20	3.10	1.05									
421 - 423		15.50	6.35	5.35	3.30	1.25									
423 - 425		15.65	6.50	5.50	3.45	1.40									
425 - 427		15.80	6.70	5.65	3.60	1.55									
427 - 429		15.95	6.85	5.80	3.75	1.70									
429 - 431		16.10	7.00	5.95	3.90	1.85									
431 - 433		16.25	7.15	6.15	4.10	2.00									
433 - 435		16.45	7.30	6.30	4.25	2.20	.15								
435 - 437		16.60	7.45	6.45	4.40	2.35	.30								
437 - 439		16.75	7.65	6.60	4.55	2.50	.45								
439 - 441		16.90	7.80	6.75	4.70	2.65	.60								
441 - 443		17.05	7.95	6.90	4.85	2.80	.75								
443 - 445		17.20	8.10	7.10	5.05	2.95	.90								
445 - 447		17.40	8.25	7.25	5.20	3.15	1.10								
447 - 449		17.55	8.40	7.40	5.35	3.30	1.25								
449 - 451		17.70	8.60	7.55	5.50	3.45	1.40								

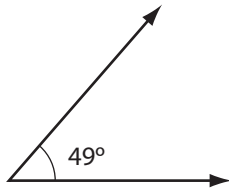
Solutions

Lesson A: Sketching and Measuring Angles

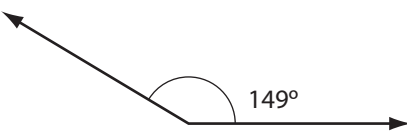
Lesson A: Activity 1: Self-Check

1. a. 63°
- b. 114°
- c. 82°
- d. 161°

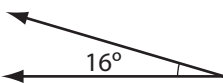
2. a.



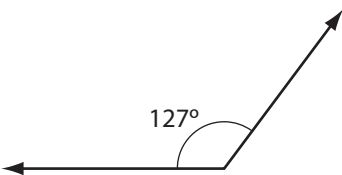
b.



c.



d.



Lesson A: Activity 2: Try This

1. Each angle is one quarter of one full rotation (one full circle). There are 360° in one full rotation.

$$\frac{1}{4} \times 360^\circ = 90^\circ$$

One quarter of a full rotation is 90° .

2. By folding the paper again, you have divided the circle into eighths.

$$\begin{aligned}\text{Each angle} &= \frac{1}{8} \times 360^\circ \\ &= 45^\circ\end{aligned}$$

You could also think of this in the following way: You know that a quarter of a full rotation is 90° . By folding the quarter in half, you have divided the 90° angle in half. Half of 90° is 45° .

3. By folding the paper again, you have divided the circle into sixteenths.

$$\begin{aligned}\text{Each angle} &= \frac{1}{16} \times 360^\circ \\ &= 22.5^\circ\end{aligned}$$

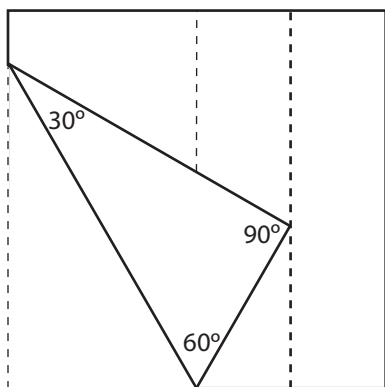
You could also think of this in the following way: You know that an eighth of a full rotation is 45° . By folding the eighth in half, you have divided the 45° angle in half. Half of 45° is 22.5° .

Lesson A: Activity 3: Try This

1. Each narrow strip is $\frac{1}{4}$ of the entire sheet since these strips were obtained by folding in half twice.

$$\begin{aligned}1 \text{ page} \div 2 \div 2 &= 1 \div 2 \div 2 \\ &= 1 \times \frac{1}{2} \times \frac{1}{2} \\ &= \frac{1}{4}\end{aligned}$$

2. The angles are 90° , 60° , and 30° as shown in the picture below.

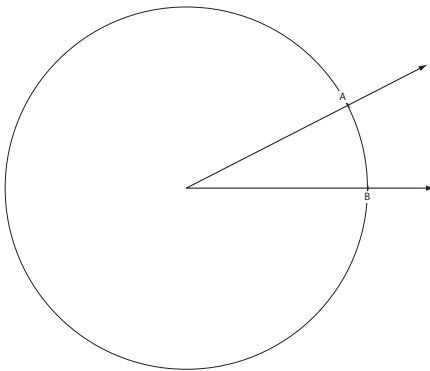


Lesson A: Activity 4: Self-Check

1.
 - a. obtuse
 - b. Estimates will vary. The angle is bigger than 90° by an amount close to the reference angle 22.5° , so the angle is close to 112.5° .
 - c. 108°
2.
 - a. obtuse
 - b. Estimates will vary. The angle is bigger than 90° by an amount close to the reference angle 45° . The angle is close to 135° .
 - c. 130°
3.
 - a. reflex
 - b. Estimates will vary. The angle is bigger than 180° by at least 60° . Using the reference angles 60° and 22.5° you can see that the angle is close to 262.5° .
 - c. 260°
4.
 - a. acute
 - b. Estimates will vary. The angle is close to 45° .
 - c. 42°

Lesson A: Activity 5: Mastering Concepts

1.



$$\begin{aligned} \text{Circumference} &\approx 6 \times \text{radius} \\ &\approx 6 \times 6 \text{ cm} \\ &\approx 36 \text{ cm} \end{aligned}$$

2. $36 \times 10 = 360$

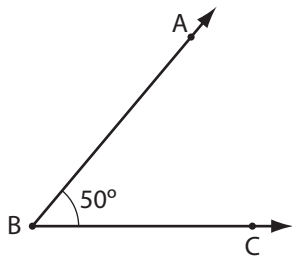
3. 360 is also the number of degrees in a circle. So, a portion of the circumference of a circle 6 cm in radius when multiplied by 10 is approximately the number of degrees in the angle at the centre of that circle.

Lesson B: Constructing Congruent Angles

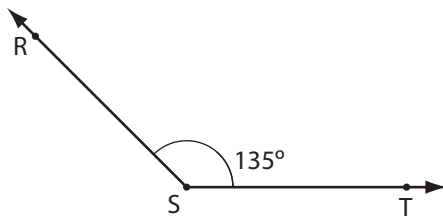
Lesson B: Activity 1: Self-Check

1. a. $\angle Q$ or $\angle PQR$
 b. $\angle U$ or $\angle TUV$
 c. There are four angles: $\angle POL$, $\angle POM$, $\angle MOQ$, and $\angle QOL$.

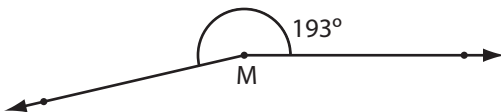
2. a.



- b.



- c.



Lesson B: Activity 2: Self-Check

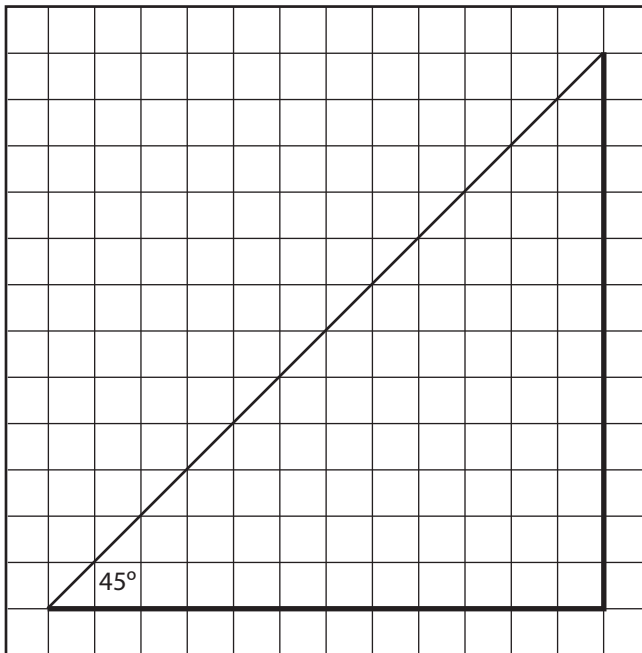
1. $\angle ABC \cong \angle EBD \cong \angle FGH = 160^\circ$
 $\angle ABE \cong \angle CBD = 120^\circ$
 $\angle FGI \cong \angle HGI = 100^\circ$
2. a. $\angle ABC \cong \angle ADC$
 $\angle BAD \cong \angle BCD$
 b. $\angle ABC \cong \angle BCD \cong \angle CDE \cong \angle DEF \cong \angle EFA \cong \angle FAB$
 c. $\angle CAB \cong \angle CBA$

Lesson B: Activity 3: Self-Check

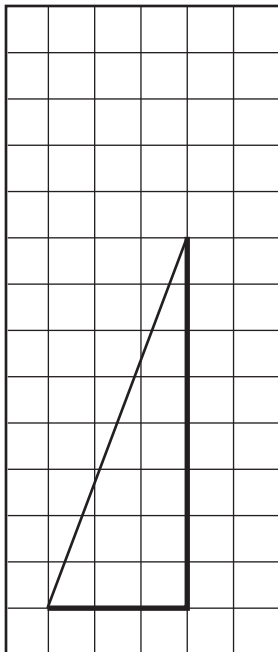
Answers will vary. Each angle you constructed should have the same measure as $\angle ABC$ that you drew.

Lesson B: Activity 4: Self-Check

1. From the grid, the rise is 12 in for a run of 12 in. This combination yields a 45° pitch.



2. Answers will vary. A sample answer is given. Use 1 unit for every foot.



The measure of the angle is about 69.5° .

Lesson B: Activity 5: Mastering Concepts

- c. $\angle A$ is larger than $\angle B$

$$\angle A = 34^\circ$$

$$\angle B = 30^\circ$$

Note that the size of an angle does not depend on how long its arms are drawn. The size of an angle depends on how far one arm is rotated away from the other.

Lesson C: Bisecting Angles

Lesson C: Activity 1: Self-Check

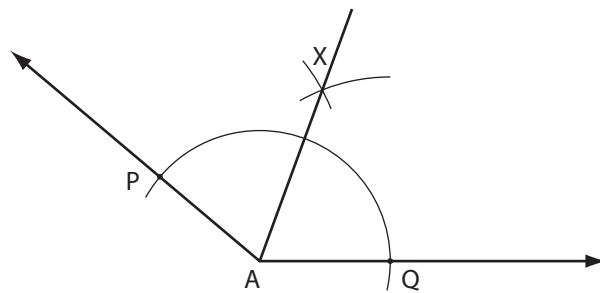
1. The two angles are the same size.
2. The angle between the pencil and the mirror is half the size of the angle between the pencil and its image.

Lesson C: Activity 2: Try This

- Step 1:** Fold the sheet of paper so that the fold goes through the vertex of $\angle ABC$ and ray BA falls on BC.
Step 2: Unfold the sheet. Draw ray BD along the crease between the arms of the angle and. Ray BD is the bisector.
- BD is the bisector of $\angle ABC$ since BD divides $\angle ABC$ into two congruent parts.
- The measures of the angles will vary, but $\angle ABD = \angle CBD = \frac{1}{2} \angle ABC$.

Lesson C: Activity 3: Self-Check

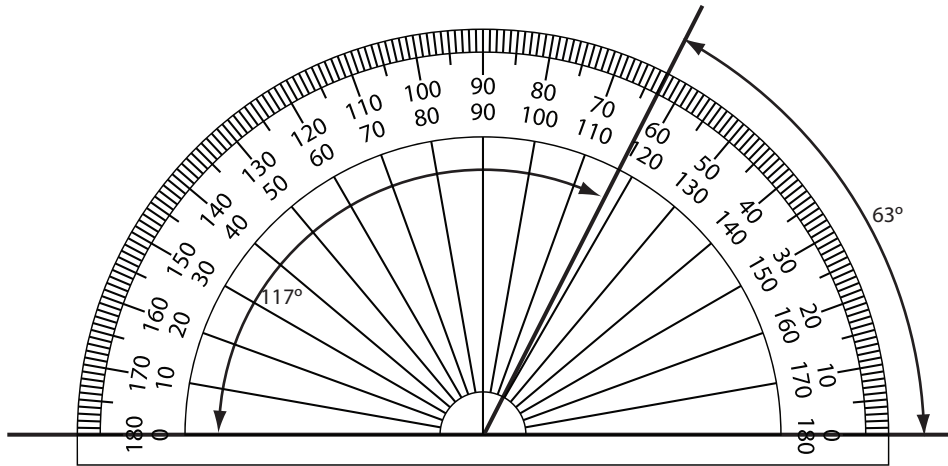
- Answers will vary depending on the obtuse angle you drew. Refer back to the multimedia segment demonstrating the steps for bisecting an angle using a compass.



If you have done your work carefully, $\angle PAX \cong \angle QAX$; that is, both angles are equal in measure.

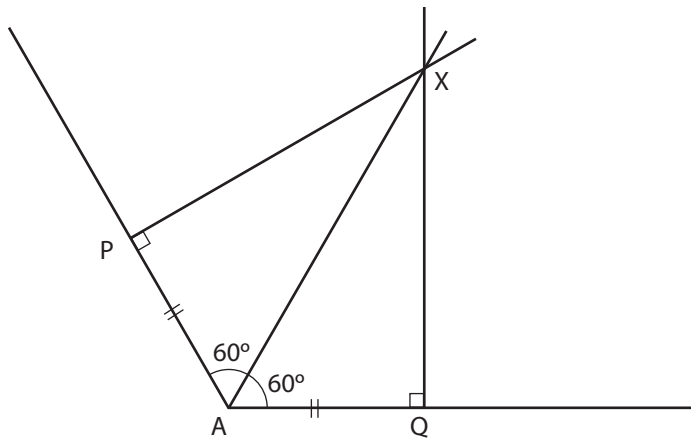
And, $\angle PAX = \angle QAX = \frac{1}{2} \angle PAQ$.

2. The student likely used the wrong scale on the protractor when measuring half of the angle. The measure of each half of the angle should be 117° , (using the lower scale on the protractor pictured below), not 63° (the upper scale).
 $\frac{1}{2} \times 234^\circ = 117^\circ$.



Lesson C: Activity 4: Self-Check

The construction is shown below.

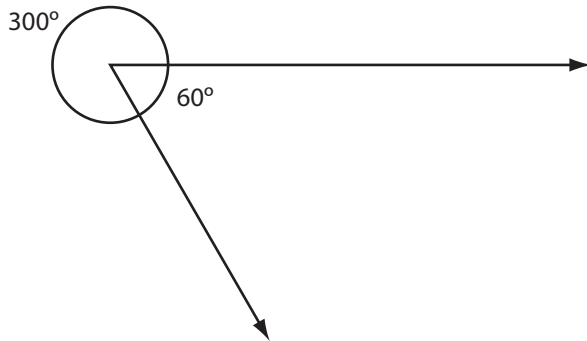


Each half of the original angle must measure 60° .

Lesson C: Activity 5: Mastering Concepts

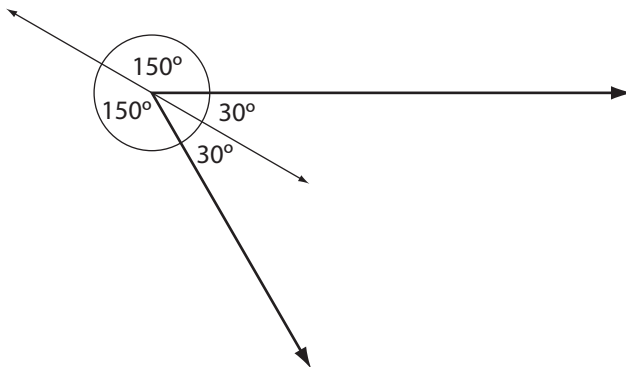
Zander is right!

Suppose Zander was asked to bisect the following 300° angle.



The 300° angle lies on the left and the 60° angle, which completes the full rotation, lies on the right. Remember, 1 full rotation = 360° , and here, $300^\circ + 60^\circ = 360^\circ$.

The bisector of the 60° angle divides it into two 30° angles. If you extend that bisector to the left, you will divide the 300° angle into two 150° angles. This is because $30^\circ + 150^\circ = 180^\circ$, and the bisector, when extended, forms straight angles.



Lesson D: Relationships Among Angles

Lesson D: Activity 1: Try This

1. A straight angle was formed. A straight angle is 180° . This is the value we got when we found the sum of the angles of the triangle.
2. The sum should be the same for any angle you draw. It was the same for the two that you drew, and you could have drawn a triangle of ANY shape and size!

Lesson D: Activity 2: Self-Check

The first pair is not adjacent because they do not share a vertex.

The second pair is not adjacent because they do not share a vertex or arm.

The third pair is not adjacent because they do not lie on opposite sides of a common arm.

Lesson D: Activity 3: Try This

1. $\angle 1 = 124^\circ$
 $\angle 2 = 56^\circ$
 $\angle 3 = 124^\circ$
 $\angle 4 = 56^\circ$
2. $\angle 1 + \angle 2 = 180^\circ$
 $\angle 1 + \angle 4 = 180^\circ$
 $\angle 3 + \angle 4 = 180^\circ$
 $\angle 2 + \angle 3 = 180^\circ$
3. The sums are all 180° .
4. a. They are the same size, but they are not adjacent.
 b. They are the same size, but they are not adjacent.

Lesson D: Activity 4: Self-Check

1. adjacent:
 $\angle ABC$ & $\angle CBE$
 $\angle CBE$ & $\angle EBD$
 $\angle EBD$ & $\angle DBA$
 $\angle DBA$ & $\angle ABC$
2. complementary:
 $\angle PQR$ & $\angle STU$
3. supplementary:
 $\angle ABC$ & $\angle CBE$
 $\angle CBE$ & $\angle EBD$
 $\angle EBD$ & $\angle DBA$
 $\angle DBA$ & $\angle ABC$
 $\angle IJK$ & $\angle LMN$
4. vertically opposite:
 $\angle ABD$ & $\angle CBE$
 $\angle ABC$ & $\angle DBE$

Lesson D: Activity 5: Self-Check

1. a. Since $\angle ABC$ is a right angle, $\angle ABD$ and $\angle DBC$ are complementary.
 Also, $\angle A$ and $\angle C$ are complementary because if one angle in a triangle is 90° , the other two angles must add up to 90° .
- b. $\angle BDA$ and $\angle BDC$ are supplementary because they adjacent angles which form a straight angle.

$$2. \quad b + 90^\circ = 180^\circ$$

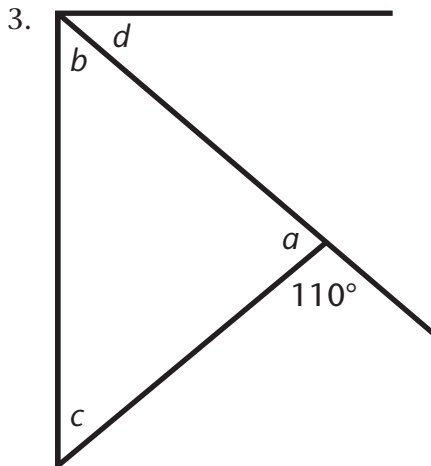
$$\quad \quad b = 180^\circ - 90^\circ$$

$$\quad \quad b = 90^\circ$$

$$a + 50^\circ = 90^\circ$$

$$\quad \quad a = 90^\circ - 50^\circ$$

$$\quad \quad a = 40^\circ$$



$$a + 110^\circ = 180^\circ$$

$$\quad \quad a = 180^\circ - 110^\circ$$

$$\quad \quad a = 70^\circ$$

$$a + b + c = 180^\circ$$

$$70^\circ + b + b = 180^\circ$$

$a = 70^\circ$ and $c = b$

$$70^\circ + 2b = 180^\circ$$

$$\quad \quad 2b = 180^\circ - 70^\circ$$

$$\quad \quad 2b = 110^\circ$$

$$\quad \quad \frac{2b}{2} = \frac{110^\circ}{2}$$

$$\quad \quad b = 55^\circ$$

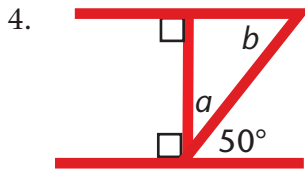
Since $b = c$, $c = 55^\circ$.

$$b + d = 90^\circ$$

$$55^\circ + d = 90^\circ$$

$$\quad \quad d = 90^\circ - 55^\circ$$

$$\quad \quad d = 35^\circ$$



$$a + 50^\circ = 90^\circ$$

$$a = 90^\circ - 50^\circ$$

$$a = 40^\circ$$

In the triangle.

$$a + b + 90^\circ = 180^\circ$$

$$40^\circ + b + 90^\circ = 180^\circ$$

$$b + 130^\circ = 180^\circ$$

$$b = 180^\circ - 130^\circ$$

$$b = 50^\circ$$

5. $a = 20^\circ$ Opposite angles

$20^\circ + b = 180^\circ$

$b = 180^\circ - 20^\circ$ Supplementary angles

$b = 160^\circ$

$c = b = 160^\circ$ Opposite angles

$a + d + 100^\circ = 180^\circ$ Triangle sum

$20^\circ + d + 100^\circ = 180^\circ$ $a = 20^\circ$

$d + 120^\circ = 180^\circ$

$d = 180^\circ - 120^\circ$

$d = 60^\circ$

Lesson D: Activity 6: Mastering Concepts

1. $\angle A + \angle B + \angle ACB = 180^\circ$
 So, $\angle A + \angle B = 180^\circ - \angle ACB$
 $\angle ACD + \angle ACB = 180^\circ$
 So, $\angle ACD = 180^\circ - \angle ACB$
 Therefore, $\angle A + \angle B = \angle ACD$
 For example, if $\angle A = 40^\circ$ and $\angle B = 60^\circ$, then $\angle ACD = 40^\circ + 60^\circ = 100^\circ$.
2. a. $\angle 1 + \angle 2 = 180^\circ$, because they form a straight angle.
 b. $\angle 3 + \angle 2 = 180^\circ$, because they form a straight angle.

- c. Since $\angle 1 + \angle 2 = \angle 3 + \angle 2$,
 $\angle 1 + \angle 2 - \angle 2 = \angle 3 + \angle 2 - \angle 2$
 $\angle 1 = \angle 3$
 Therefore, $\angle 1 \cong \angle 3$.
- d. Since $\angle 2 + \angle 1 = \angle 4 + \angle 1$,
 $\angle 2 + \angle 1 - \angle 1 = \angle 4 + \angle 1 - \angle 1$
 $\angle 2 = \angle 4$
 Therefore, $\angle 2 \cong \angle 4$.

Lesson E: Parallel and Perpendicular Lines

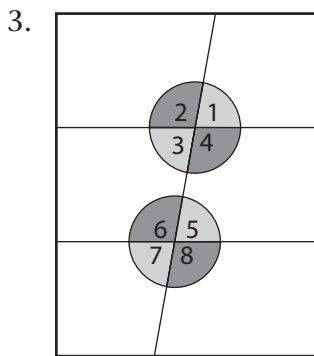
Lesson E: Activity 1: Self-Check

1. a. Parallel lines are lines that never meet. They are the same distance apart everywhere.
- b. Perpendicular lines are lines that intersect at a 90° angle.
2. a. i. parallel
- ii. These lines are parallel because if you extend the lines, they will never intersect.
- b. i. neither parallel nor perpendicular
- ii. These lines are not parallel because if you extend the lines, they will intersect. These lines are not perpendicular because, when they intersect, they do not meet at a 90° angle.
- c. i. perpendicular
- ii. These lines are perpendicular because they intersect at a 90° angle.
- d. i. neither parallel nor perpendicular
- ii. These lines are not parallel because they intersect. These lines are not perpendicular because they do not meet at a 90° angle.

Lesson E: Activity 2: Try This

Angle	Congruent to...
$\angle 1$	$\angle 3, \angle 5, \angle 7$
$\angle 2$	$\angle 4, \angle 6, \angle 8$
$\angle 3$	$\angle 1, \angle 5, \angle 7$
$\angle 4$	$\angle 2, \angle 6, \angle 8$
$\angle 5$	$\angle 1, \angle 3, \angle 7$
$\angle 6$	$\angle 2, \angle 4, \angle 8$
$\angle 7$	$\angle 1, \angle 3, \angle 5$
$\angle 8$	$\angle 2, \angle 4, \angle 6$

1. If the paper is folded so that the creases are perpendicular to the edges of the paper, then the creases will be parallel.
2. Answers will vary. You may have cut each of the pieces in half so that each piece contained one numbered angle. Alternately, you could have found an angle that was congruent to $\angle 3$. Then, you could use that congruent angle to compare with $\angle 6$. (A similar strategy could be used to compare $\angle 4$ with $\angle 5$.)



You would only need two colours.

$\angle 1, \angle 3, \angle 5,$ and $\angle 7$ would all be the same colour because $\angle 1 \cong \angle 3 \cong \angle 5 \cong \angle 7$.

$\angle 2, \angle 4, \angle 6,$ and $\angle 8$ would all be the same colour because $\angle 2 \cong \angle 4 \cong \angle 6 \cong \angle 8$.

Lesson E: Activity 3: Self-Check

1.

Angle Pair	Angle Relationship	Congruent or Supplementary?
$\angle 1$ and $\angle 3$	vertically opposite	congruent
$\angle 4$ and $\angle 8$	corresponding	congruent
$\angle 4$ and $\angle 5$	co-interior	supplementary
$\angle 3$ and $\angle 5$	alternate interior	congruent
$\angle 2$ and $\angle 8$	alternate exterior	congruent
$\angle 2$ and $\angle 7$	co-exterior	supplementary

2. a. $\angle 1 = 70^\circ$
 $\angle 2 = 110^\circ$
 $\angle 3 = 70^\circ$
 $\angle 4 = 110^\circ$
 $\angle 5 = 70^\circ$
 $\angle 6 = 110^\circ$
 $\angle 7 = 70^\circ$

- b. The measure $\angle 1$ is found by subtracting 110° from 180° . This is because the angle marked with 110° and $\angle 1$ are supplementary.

The measure of $\angle 4$ makes a corresponding angle pair with the angle marked 110° . Therefore, $\angle 4$ is also 110° .

The measure of $\angle 7$ can be found through a number of relationships.

Two such relationships are given below. You may have used one of these relationships to figure out $\angle 7$ or you may have used a different one.

- $\angle 7$ and the 110° angle are co-exterior angles; thus they are supplementary and $\angle 7$ measures 70° .
- $\angle 7$ and $\angle 1$ are alternate exterior angles; thus they are congruent and $\angle 7$ measures 70° .

Lesson E: Activity 4: Self-Check

1. a. $\overline{AB} \parallel \overline{CD}$ because both segments are perpendicular to the base of the triangle. The right angles marked are corresponding angles. If corresponding angles are congruent, the segments are parallel.

b. $x + 50^\circ = 180^\circ$
 $x = 180^\circ - 50^\circ$
 $x = 130^\circ$

Co-interior angles are supplementary.

2. $x + 143^\circ = 180^\circ$
 $x = 180^\circ - 143^\circ$
 $x = 37^\circ$

Co-exterior angles are supplementary.

Lesson E: Activity 5: Mastering Concepts

$\angle A \cong \angle ACE$

Alternate interior angles are congruent.

$\angle B \cong \angle DCE$

Corresponding angles are congruent.

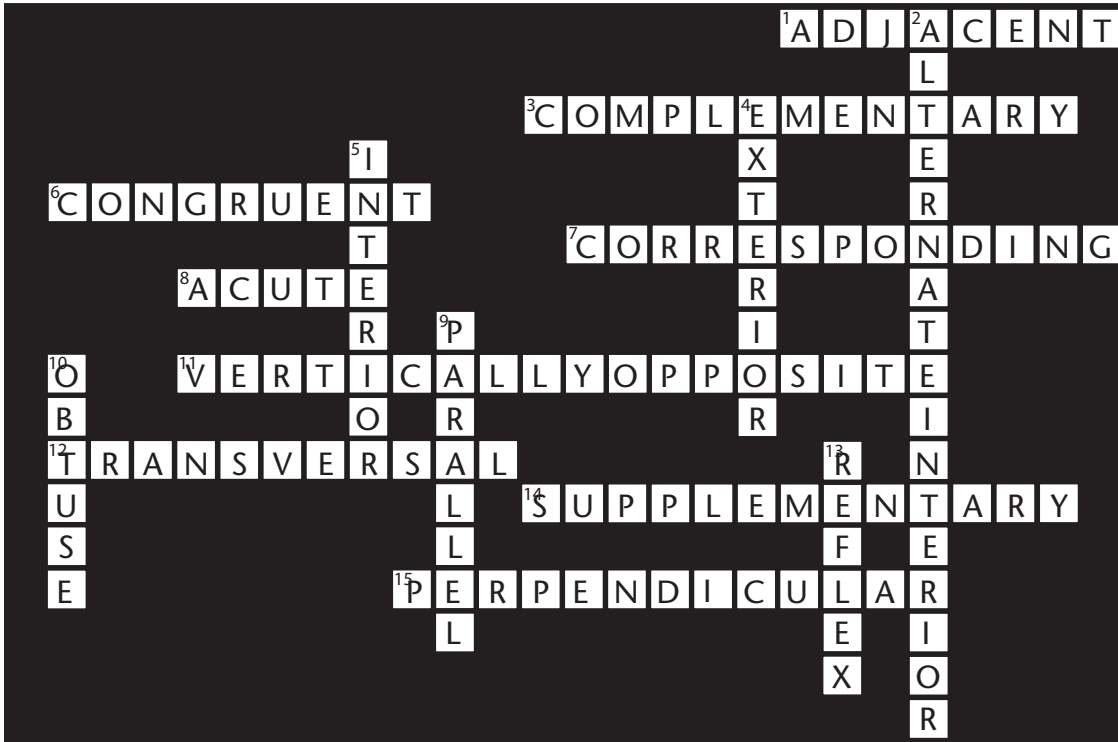
Therefore, $\angle A + \angle B = \angle ACE + \angle DCE$

But $\angle ACE + \angle DCE = \angle ACD$.

Therefore, $\angle A + \angle B = \angle ACD$

Lesson F: Solving Problems Using Angle Relationships

Lesson F: Activity 1: Self-Check



Lesson F: Activity 2: Self-Check

- Since the vertical bridge supports are parallel,
 $x = 32^\circ$ — Alternate interior angles are congruent.
- $b + 40^\circ = 180^\circ$ — co-interior angles
 $b = 180^\circ - 40^\circ$
 $b = 140^\circ$
 $a = b$ — corresponding angles
 $a = 140^\circ$
- $a = 75^\circ$ — Alternate exterior angles are congruent.

4. $\angle BCA = 40^\circ$

Corresponding angles are congruent.

$$\angle B + \angle BCA + \angle A = 180^\circ$$

triangle angle sum

$$\angle B + 40^\circ + 60^\circ = 180^\circ$$

$$\angle B + 100^\circ = 180^\circ$$

$$\angle B = 180^\circ - 100^\circ$$

$$\angle B = 80^\circ$$

5. Since \overleftrightarrow{AC} and \overleftrightarrow{DF} are parallel, the co-interior angles formed by \overline{BE} are supplementary.

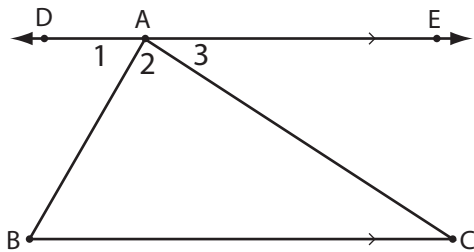
$$\angle ABE + \angle BED = 180^\circ$$

$$90^\circ + \angle BED = 180^\circ$$

$$\angle BED = 180^\circ - 90^\circ$$

$$\angle BED = 90^\circ$$

Lesson F: Activity 3: Mastering Concepts



\overleftrightarrow{DE} is parallel to \overline{BC} .

\overline{AB} is a transversal, so $\angle B$ and $\angle 1$ are alternate interior angles and are congruent.

\overline{AC} is a transversal, so $\angle C$ and $\angle 3$ are alternate interior angles and are congruent.

Since $\angle DAE$ is a straight angle, $\angle DAE = 180^\circ$. It follows that:

$$\angle 1 + \angle 2 + \angle 3 = 180^\circ$$

Since

$$\angle 1 \cong \angle B \text{ and } \angle 3 \cong \angle C,$$

$$\angle B + \angle 2 + \angle C = 180^\circ$$

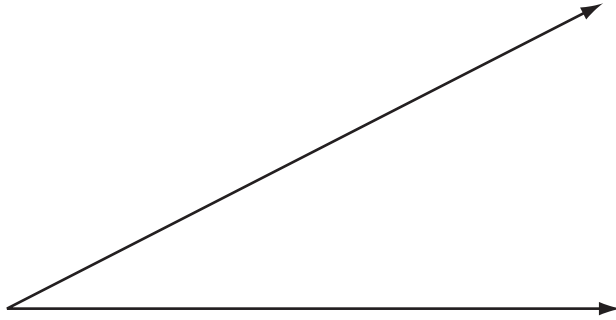
This proves that the three angles of $\triangle ABC$, $\angle B$, $\angle 2$, and $\angle C$, add up to 180° .

Glossary

acute angle

an angle greater than 0° but less than 90°

For example, this is an acute angle.



adjacent angles

angles which share a common vertex and lie on opposite sides of a common arm

adjacent side

the side next to the reference angle in a right triangle. (The adjacent side cannot be the hypotenuse.)

alternate exterior angles

exterior angles lying on opposite sides of the transversal

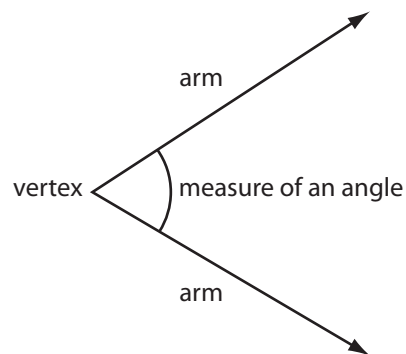
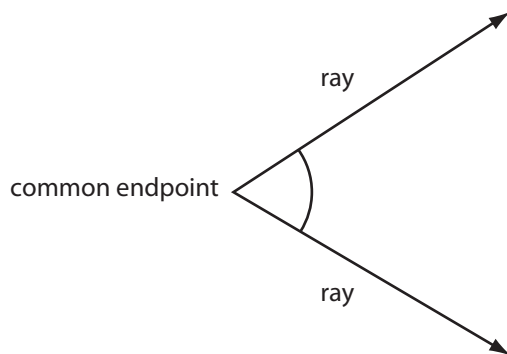
alternate interior angles

interior angles lying on opposite sides of the transversal

angle

a geometric shape formed by two rays with a common endpoint

Each ray is called an *arm of the angle*. The common endpoint of the arms of the angle is the vertex of the angle.



angle of depression

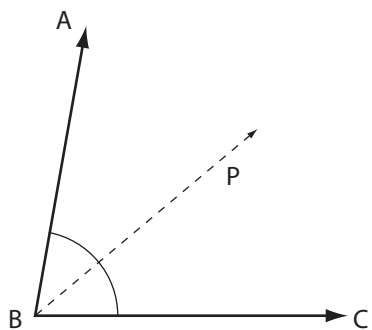
an angle below the horizontal that an observer must look down to see an object that is below the observer

angle of elevation

the angle above the horizontal that an observer must look to see an object that is higher than the observer

bisect

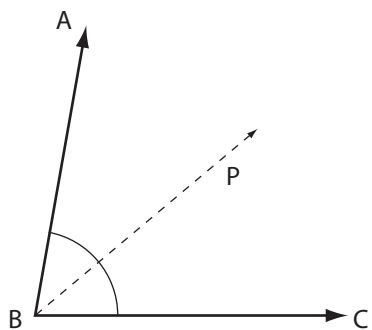
divide into two congruent (equal in measure) halves



bisector

a line or ray which divides a geometric shape into congruent halves

Ray BP is a bisector of $\angle ABC$, since it bisects $\angle ABC$ into two congruent halves.



$$\angle ABP \cong \angle PBC$$

clinometer

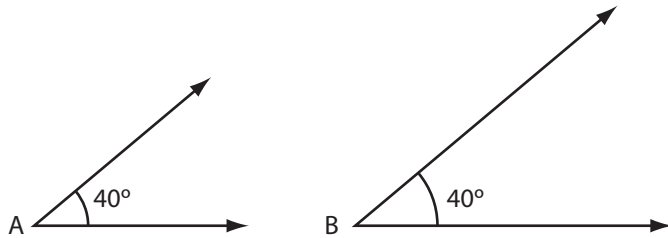
a device for measuring angles to distant objects that are higher or lower than your position

complementary angles

two angles with measures that add up to 90°
 One angle is called the *complement* to the other.

congruent angles

angles with the same measure



In the diagram $\angle A = 40^\circ$ and $\angle B = 40^\circ$. So, $\angle A$ and $\angle B$ are congruent.
 There is a special symbol for “is congruent to.” The congruence symbol is \cong .
 So, you can write $\angle A \cong \angle B$.

corresponding angles

angles in the same relative positions when two lines are intersected by a transversal

cosine ratio

the ratio of the length of the side adjacent to the reference angle, to the length of the hypotenuse of the right triangle

exterior angles

angles lying outside two lines cut by a transversal

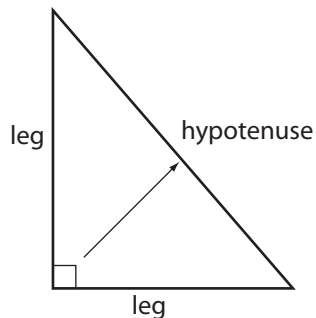
full rotation

an angle having a measure of 360°
 This is a full rotation angle.



hypotenuse

in a right triangle, the side opposite the right angle; the longest side in a right triangle



indirect measurement

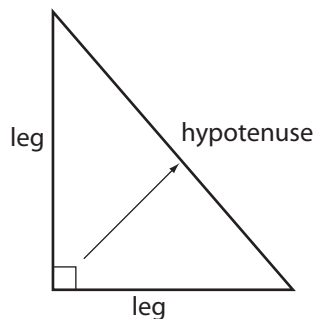
taking one measurement in order to calculate another measurement

interior angles

angles lying between two lines cut by a transversal

leg

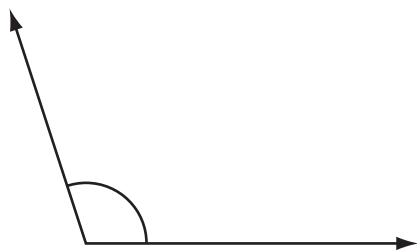
one of the two sides of a right triangle that forms the right angle



obtuse angle

an angle greater than 90° but less than 180°

For example, this is an obtuse angle.



opposite side

the side across from the reference angle in a right triangle

parallel

lines that are the same distance apart everywhere: they never meet

perpendicular

lines that meet at right angles

polygon

a many-sided figure

A triangle is a polygon with three sides, a quadrilateral is a polygon with four sides, and so on.

proportion

the statement showing two ratios are equal

Pythagorean Theorem

for any right triangle, the square of the hypotenuse is equal to the sum of the squares of the two legs

Pythagorean triple

three whole numbers, which represent the lengths of the sides of a right triangle

There are an infinite number of such triples.

reference angle

an acute angle that is specified (example, shaded) in a right triangle

referent

an object or part of the human body you can refer to when estimating length or distance

reflex angle

an angle having a measure greater than 180° but less than 360°

This is an example of a reflex angle.



regular polygon

a polygon with all its angles equal in measure and all its sides equal in measure

right angle

one quarter of a complete rotation. It is 90° in measure.

scale factor

the number by which the length and the width of a figure is multiplied to form a larger or smaller similar figure

similar figures

figures with the same shape but not necessarily the same size

A figure similar to another may be larger or smaller

sine ratio

the ratio of the length of the side opposite to the reference angle, over the hypotenuse of the right triangle

solve a right triangle

to find all the missing sides and angles in a right triangle

straight angle

one half a rotation; an angle 180°

This is a straight angle.



straightedge

a rigid strip of wood, metal, or plastic having a straightedge used for drawing lines
When a ruler is used without reference to its measuring scale, it is considered to be a straightedge.

supplementary angles

two angles, which add up to 180°

In a pair of supplementary angles, one angle is the supplement to the other.

symmetry

the property of being the same in size and shape on both sides of a central dividing line

tangent ratio

the ratio of the length of the side opposite to the selected acute angle, to the length of the side adjacent to the selected acute angle in a right triangle

transversal

a line that cuts across two or more lines

trigonometry

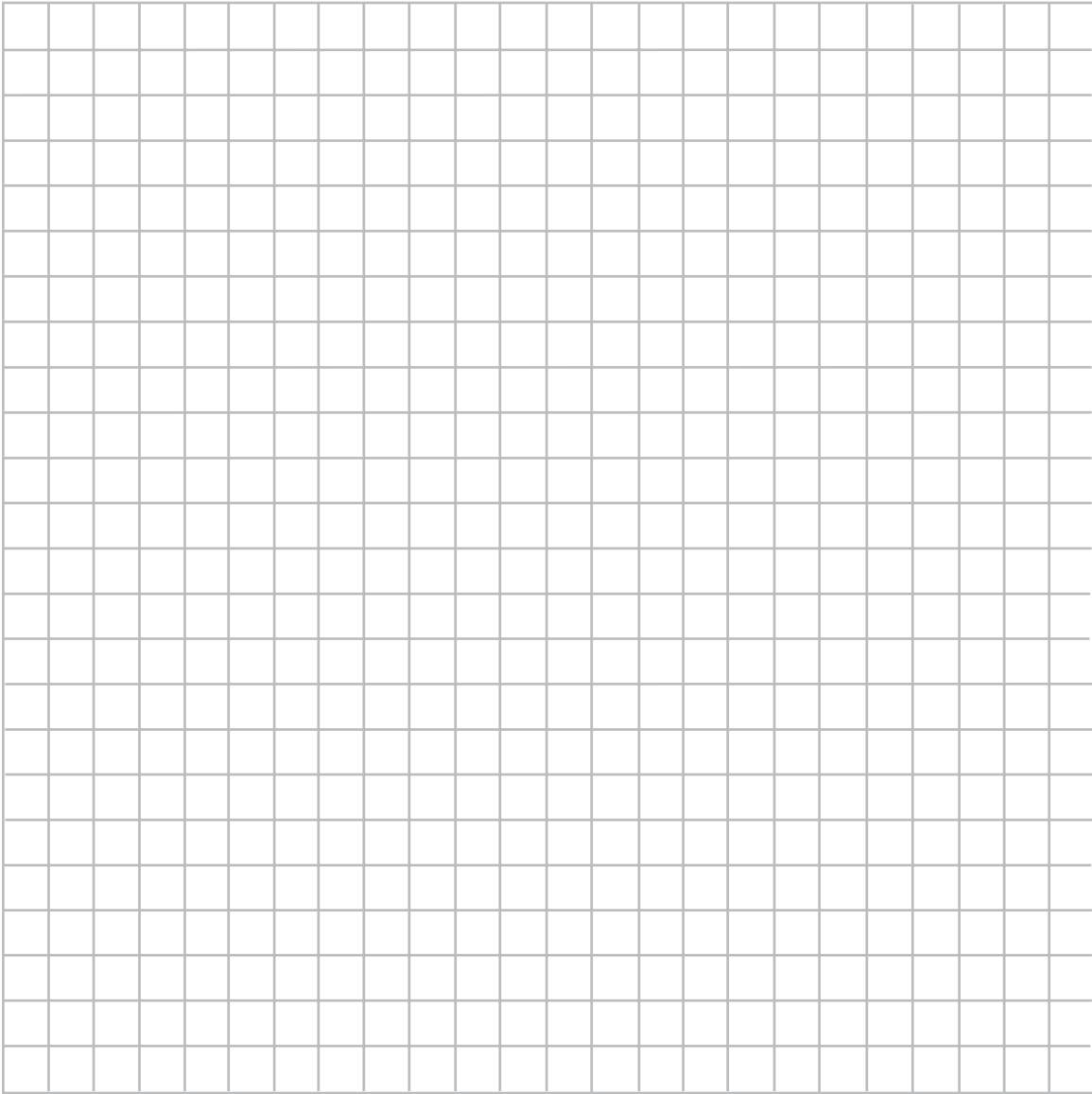
the branch of mathematics based originally on determining sides and angles of triangles, particularly right triangles

vertically opposite angles

angles lying across from each other at the point where two lines intersect

Vertically opposite angles are also referred to as *opposite angles*.

Grid Paper



This book is shared online by Free Kids Books at <https://www.freekidsbooks.org> in terms of the creative commons license provided by the publisher or author.

Want to find more books like this?



<https://www.freekidsbooks.org>

Simply great free books -

Preschool, early grades, picture books, learning to read,
early chapter books, middle grade, young adult,

Pratham, Book Dash, Mustardseed, Open Equal Free, and many more!

Always Free – Always will be!

Legal Note: This book is in CREATIVE COMMONS - Awesome!! That means you can share, reuse it, and in some cases republish it, but only in accordance with the terms of the applicable license (not all CCs are equal!), attribution must be provided, and any resulting work must be released in the same manner.

Please reach out and contact us if you want more information:

<https://www.freekidsbooks.org/about> Image Attribution: Annika Brandow, from You! Yes You! CC-BY-SA. This page is added for identification.