

*Transforming Mathematics Education*

SECONDARY  
MATH THREE

*An Integrated Approach*

Standard Teacher Notes

MODULE 5

# Modeling With Geometry

MATHEMATICSVISIONPROJECT.ORG

**The Mathematics Vision Project**

*Scott Hendrickson, Joleigh Honey, Barbara Kuehl, Travis Lemon, Janet Sutorius*

© 2018 Mathematics Vision Project

Original work © 2013 in partnership with the Utah State Office of Education

This work is licensed under the Creative Commons Attribution CC BY 4.0





# MODULE 5 - TABLE OF CONTENTS

## MODELING WITH GEOMETRY

### **5.1 Any Way You Slice It – A Develop Understanding Task**

Visualizing two-dimensional cross sections of three dimensional objects (G.GMD.4)

**READY, SET, GO Homework:** *Modeling with Geometry 5.1*

### **5.2 Any Way You Spin It – A Develop Understanding Task**

Visualizing solids of revolution (G.GMD.4)

**READY, SET, GO Homework:** *Modeling with Geometry 5.2*

### **5.3 Take Another Spin – A Solidify Understanding Task**

Approximating volumes of solids of revolution with cylinders and frustums (G.MG.1, G.GMD.4)

**READY, SET, GO Homework:** *Modeling with Geometry 5.3*

### **5.4 You Nailed It! – A Practice Understanding Task**

Solving problems using geometric modeling (G.MG.1, G.MG.2, G.MG.3)

**READY, SET, GO Homework:** *Modeling with Geometry 5.4*

### **5.5 Special Rights – A Solidify Understanding Task**

Examining the relationship of sides in special right triangles (G.SRT.11)

**READY, SET, GO Homework:** *Modeling with Geometry 5.5*

### **5.6 More Than Right – A Develop Understanding Task**

Developing strategies for solving non-right triangles (G.SRT.10, G.SRT.11)

**READY, SET, GO Homework:** *Modeling with Geometry 5.6*

**5.7 Justifying the Laws – A Solidify Understanding Task**

Examining the Law of Cosines and the Law of Sines (G.SRT.10, G.SRT.11)

**READY, SET, GO Homework:** *Modeling with Geometry 5.7*

**5.8 Triangle Areas by Trig – A Practice Understanding Task**

Finding the missing sides, angles and areas of general triangles (G.SRT.9, G.SRT.10, G.SRT.11)

**READY, SET, GO Homework:** *Modeling with Geometry 5.8*

## 5.1 Any Way You Slice It

### A Develop Understanding Task

Students in Mrs. Denton's class were given cubes made of clay and asked to slice off a corner of the cube with a piece of dental floss.

Jumal sliced his cube this way.

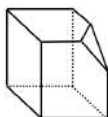

Jabari sliced his cube like this.

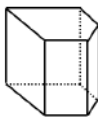

CC BY Sean Freese  
<https://flic.kr/p/bZrxdy>

1. Which student, Jumal or Jabari, interpreted Mrs. Denton's instructions correctly?  
Why do you say so?

When describing three-dimensional objects such as cubes, prisms or pyramids we use precise language such as *vertex*, *edge* or *face* to refer to the parts of the object in order to avoid the confusion that words like "corner" or "side" might create.

A **cross section** is the face formed when a three-dimensional object is sliced by a plane. It can also be thought of as the intersection of a plane and a solid.

2. Draw and describe the cross section formed when Jumal sliced his cube.
3. Draw and describe the cross section formed when Jabari sliced his cube.
4. Draw some other possible cross-sections that can be formed when a cube is sliced by a plane.

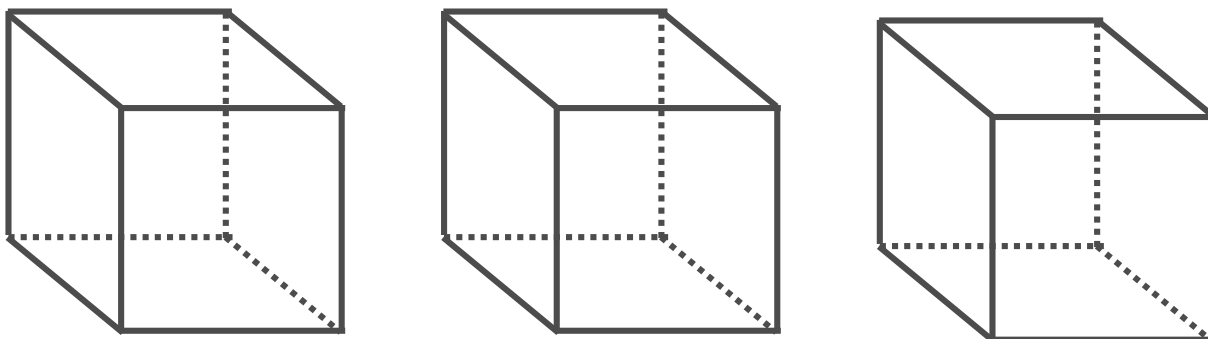

5. What type of quadrilateral is formed by the intersection of the plane that passes through diagonally opposite edges of a cube?

Explain how you know what quadrilateral is formed by this cross section.

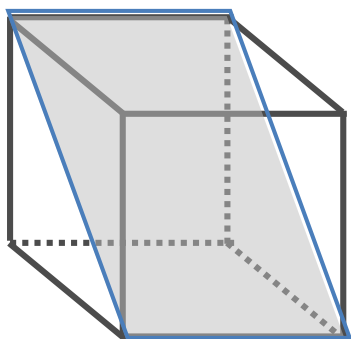

Cross sections can be visualized in different ways. One way is to do what Jumal and Jabari did—cut a clay model of the solid with a piece of dental floss. Another way is to partially fill a clear glass or plastic model of the three-dimensional object with colored water and tilt it in various ways to see what shapes the surface of the water can assume.

Experiment with various ways of examining the cross sections of different three-dimensional shapes.

6. Partially fill a cylindrical jar with colored water, and tilt it in various ways. Draw the cross sections formed by the surface of the water in the jar.

7. Try to imagine a cubical jar partially filled with colored water, and tilted in various ways. Which of the following cross sections can be formed by the surface of the water? Which are impossible?

- a square
- a rhombus
- a rectangle
- a parallelogram
- a trapezoid
- a triangle
- a pentagon
- a hexagon
- an octagon
- a circle

## 5.1 Any Way You Slice It – Teacher Notes

### *A Develop Understanding Task*

**Purpose:** The purpose of this task is to surface a variety of strategies for visualizing two-dimensional cross sections of three-dimensional objects, and to identify and/or draw such cross sections. Students encounter cross sections when they slice a loaf of bread, a piece of cake, or a hard-boiled egg, or when they tilt a glass of water in different ways and examine the surface of the water. This task aims to formalize these observations by defining a cross section as the intersection of a plane and a three-dimensional object.

**Core Standards Focus:**

**G.GMD.4** Identify the shapes of two-dimensional cross-sections of three-dimensional objects, and identify three-dimensional objects generated by rotations of two-dimensional objects.

**Standards for Mathematical Practice:**

**SMP 7 – Look for and make use of structure**

**Vocabulary:** Students will need to understand that a *cross section* is the shape of the surface formed when a geometric solid is sliced by a plane.

**The Teaching Cycle:**

**Launch (Whole Class):**

Give students a few minutes to respond to questions 1-4 individually, and then discuss them as a class. Students should note that “corner” is an ambiguous term, since it can refer to the vertex point where the edges of the cube meet, or to the three dimensional region where two faces of the cube meet, such as when we say, “Go stand in the corner of the room.” Encourage students to use more precise language as they work through this, and subsequent tasks.

Question 4 should highlight the strategy of drawing in the “edges” on the faces of the cube where the plane intersects the faces, such as in the following diagrams.



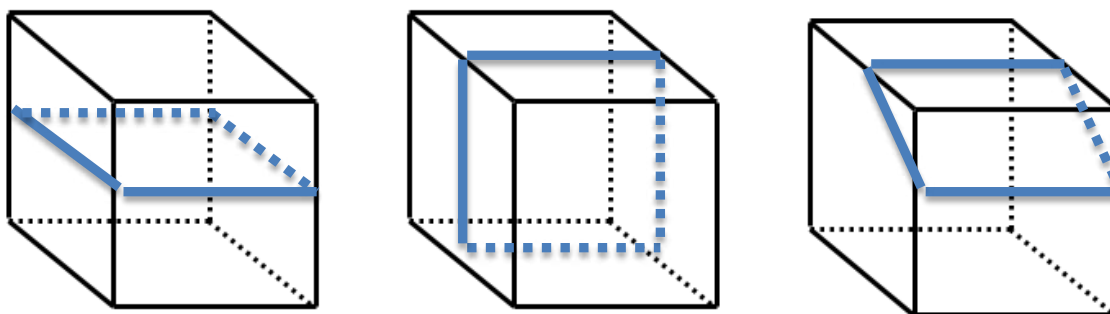

Following this introductory discussion, set students to work on the remainder of the task. Set up some stations in the classroom where students can access the materials needed to work on questions 6 and 7.

**Explore (Small Group):**

Students can discuss question 5 in small groups while waiting for their turns to access the materials for questions 6 and 7. Students may initially think that the shaded cross section in question 5 is a parallelogram (or a rhombus), since it looks like one in this two-dimensional image. Listen for students' justification as to what type of quadrilateral they claim it to be. Ask how they might justify that one side length is longer than or the same length as another. How might they reason about the angles in the quadrilateral?

If possible, for question 6 provide a variety of sealed containers, including a cylinder, each partially filled with colored water. It might be surprising to students to find that they can create rectangular cross sections in a cylinder, or a triangular cross section in a cone. As an alternative approach to this question, allow students to partially submerge objects in water and trace the "edges" where the object intersects the surface of the water. Regardless of how students collect the data, they should sketch the various types of cross sections that can be formed by intersecting a particular object with a plane.

In question 7 watch for students who find it difficult to visualize how to draw cross sections within a two-dimensional drawing of a three-dimensional object. How do they attend to the vertices,

edges and faces that would be intersected by a single plane? Watch for students who create “impossible” cross sections by using points on the same edge or face that could not possibly lie in a single plane.

**Discuss (Whole Class):**

This is an open-ended task that is intended to surface different ways of thinking about cross sections when we can’t actually experiment with an object directly. Discuss the strategies that have emerged for students and relate these back to the ideas that was introduced in question 4: specifically, to imagine tracing the “edges” of the figure outlining the surface where the plane intersects the object.

Have students draw and describe some of the cross sections they noted in various three-dimensional shapes that were unexpected or surprising to them, such as the rectangular cross sections in a cylinder or the hexagon cross section in a cube.

**Aligned Ready, Set, Go: Modeling with Geometry 5.1**

**Cube drawings for use with question #7**

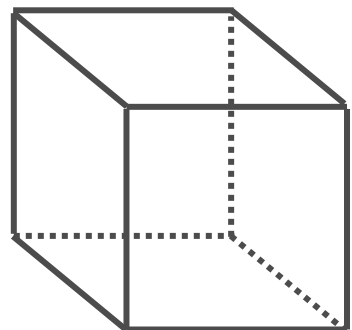
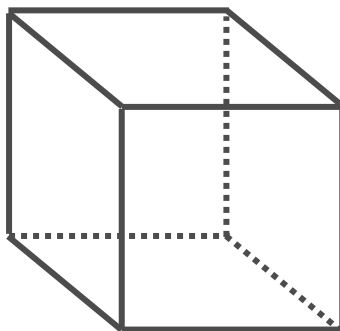
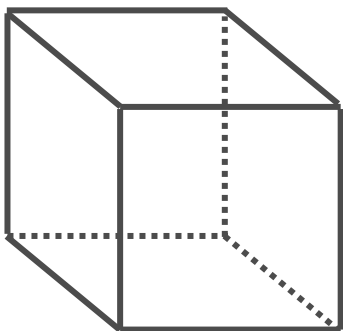
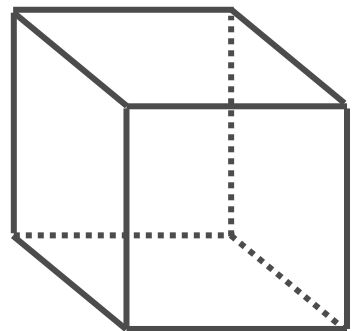
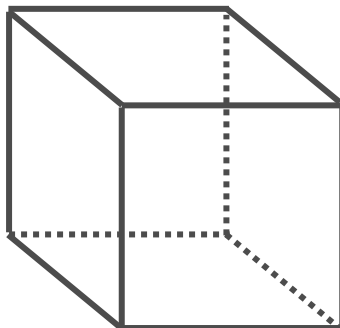
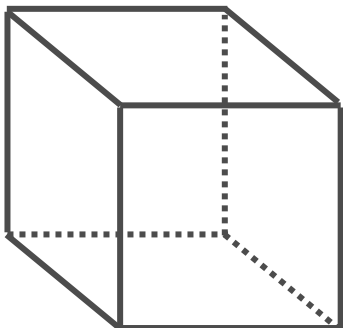
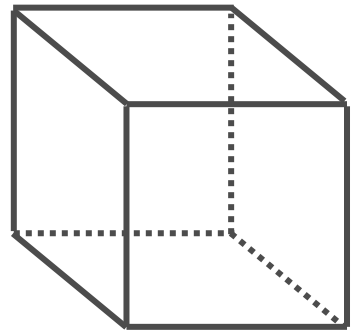
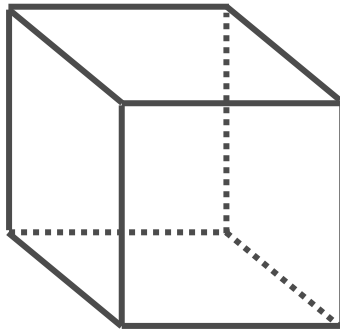
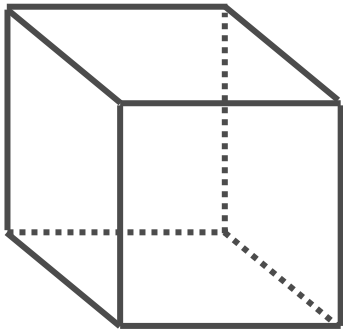

READY, SET, GO!

Name

Period

Date

**READY**

Topic: Comparing perimeter, area and volume

**Solve each of the following problems. Make certain you label the units on each of your answers.**

1. Calculate the perimeter of a rectangle that measures 5 cm by 12 cm.

2. Calculate the area of the same rectangle.

3. Calculate the volume of a rectangular box that measures 5 cm by 12 cm. and is 8 cm. deep.

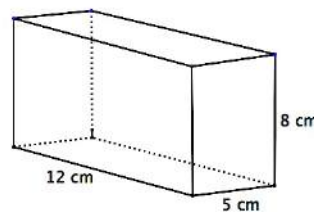

4. Look back at problems 1 – 3. Explain how the units change for each answer.

5. Calculate the surface area for the box in problem 3. Assume it does NOT have a cover on top. Identify the units for the surface area. How do you know your units are correct?

6. Calculate the circumference of a circle if the radius measures 8 inches. (Use  $\pi = 3.14$ )

7. Calculate the area of the circle in problem 6.

8. Calculate the volume of a ball with a diameter of 16 inches. ( $V = \frac{4}{3}\pi r^3$ )

9. Calculate the surface area of the ball in problem 8. ( $SA = 4\pi r^2$ )

10. If a measurement were given, could you know if it represented a perimeter, an area, or a volume? Explain.

11. In the problems above, which type of measurement would be considered a “linear measurement?”

**Need help? Visit [www.rsgsupport.org](http://www.rsgsupport.org)**

**SET**

Topic: Examining the cross sections of a cone

**Consider the intersection of a plane and a cone.**

12. If the plane were parallel to the base of the cone, what would be the shape of the cross-section? Can think of 2 possibilities? Explain.

13. How would a plane need to intersect the cone so that it would create a parabola?

14. Describe how the plane would need to intersect the cone in order to get a cross-section that is a triangle. Would the triangle be scalene, isosceles, or equilateral? Explain.

15. Would it be possible for the intersection of a plane and a cone to be a line? Explain.

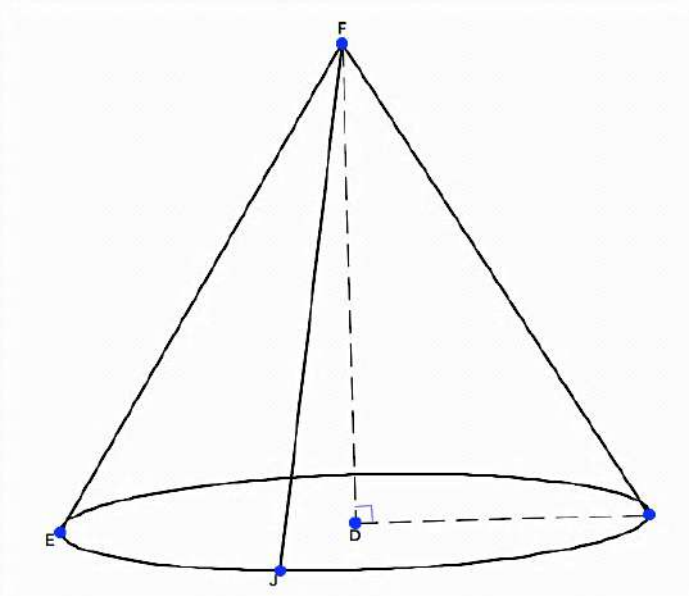

**GO**

Topic: Finding the area of a triangle

**Calculate the area of triangle EFG in each exercise below.**

16.

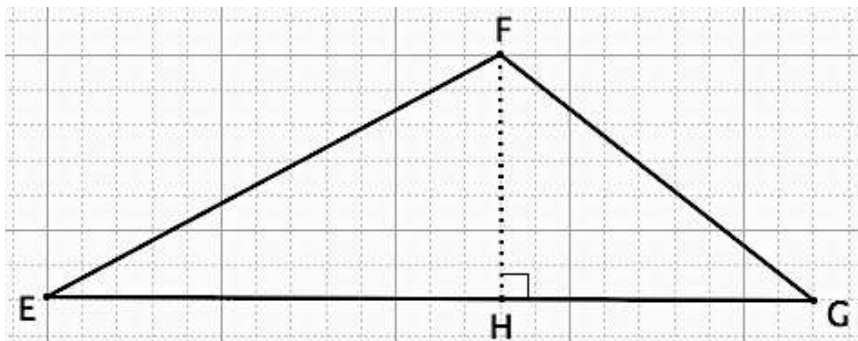

Need help? Visit [www.rsgsupport.org](http://www.rsgsupport.org)

17.

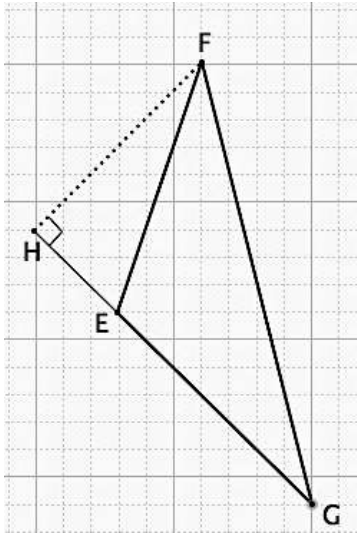

18.

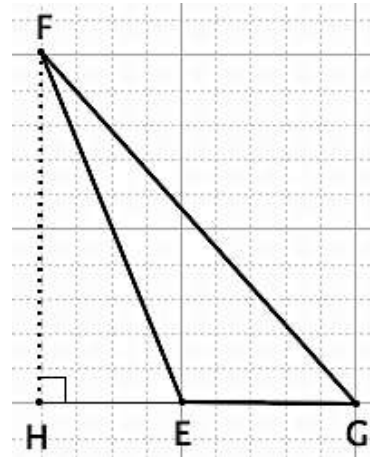

19. Calculate the areas of  $\triangle EFG$ ,  $\triangle EOG$ , and  $\triangle EMG$ . Justify your answers.

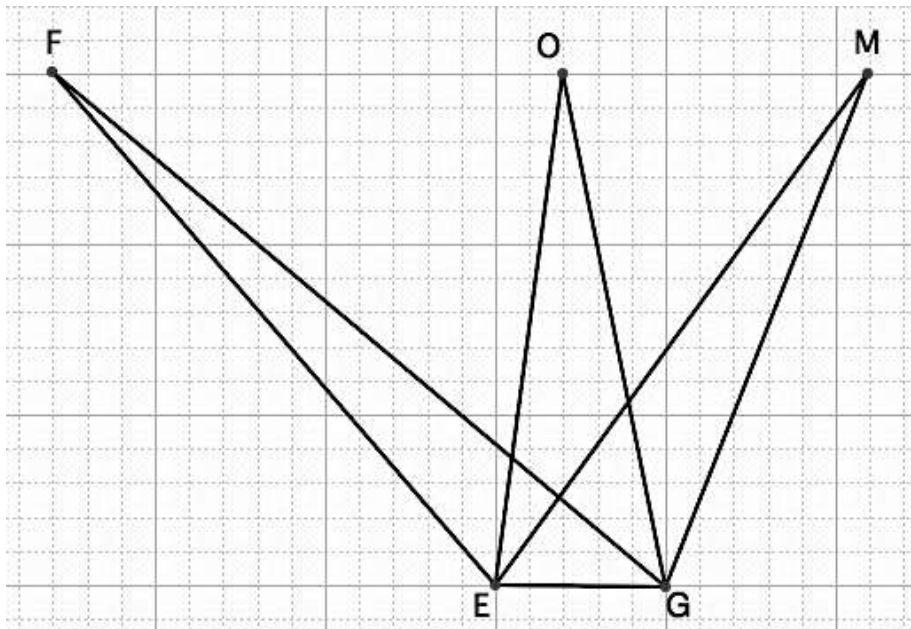

Need help? Visit [www.rsgsupport.org](http://www.rsgsupport.org)

## 5.2 Any Way You Spin It

### A Develop Understanding Task

Perhaps you have used a pottery wheel or a wood lathe. (A lathe is a machine that is used to shape a piece of wood by rotating it rapidly on its axis while a fixed tool is pressed against it. Table legs and wooden pedestals are carved on a wood lathe). You might have played with a spinning top or watched a figure skater spin so rapidly she looked like a solid blur. The clay bowl, the table leg, the rotating top and the spinning skater—each of these can be modeled as **solids of revolution**—*a three dimensional object formed by spinning a two dimensional figure about an axis.*

Suppose the right triangle shown below is rotating rapidly about the  $x$ -axis. Like the spinning skater, a solid image would be formed by the blur of the rotating triangle.

1. Draw and describe the solid of revolution formed by rotating this triangle about the  $x$ -axis.

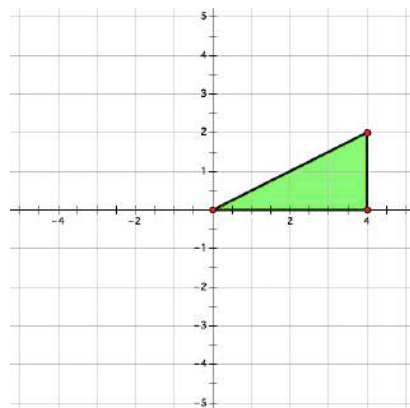

2. Find the volume of the solid formed.

3. What would this figure look like if the triangle rotates rapidly about the  $y$ -axis? Draw and describe the solid of revolution formed by rotating this triangle about the  $y$ -axis.

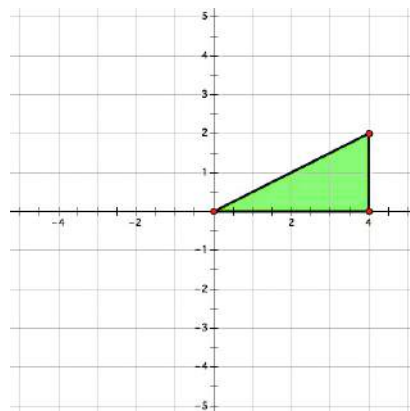

4. Find the volume of the solid formed.



CC BY Kellinahandbasket  
<https://flic.kr/p/4jYxqY>

5. What about the following two-dimensional figure? Draw and describe the solid of revolution formed by rotating this figure about the  $x$ -axis.

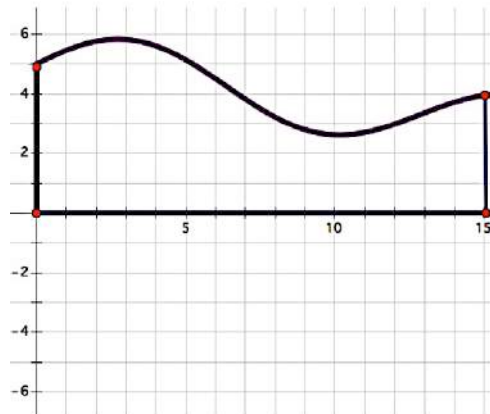

6. Draw a cross section of the solid of revolution formed by this figure if the plane cutting the solid is the plane containing the coordinate axes.

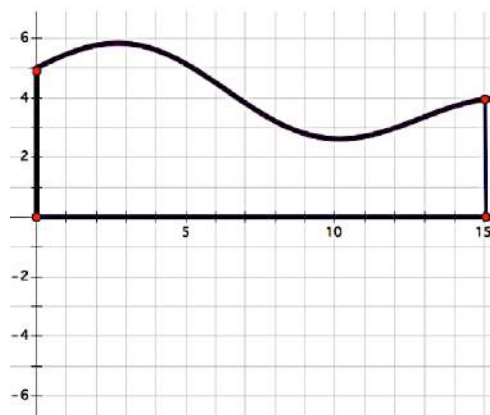

7. Draw some cross sections of the solid of revolution formed by the figure above if the planes cutting the solid are perpendicular to the plane containing the coordinate axes. Draw the cross sections when the intersecting planes are located at  $x = 5$ ,  $x = 10$  and  $x = 15$ .

So, why are we interested in solids that don't really exist—after all, they are nothing more than a blur that forms an image of a solid in our imagination. Solids of revolution are used to create



mathematical models of real solids by describing the solid in terms of the two-dimensional shape that generates it.

8. For each of the following solids, draw the two-dimensional shape that would be revolved about the  $x$ -axis to generate it.

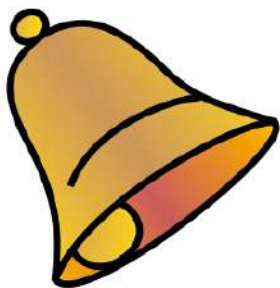

Images this page:

<http://openclipart.org/detail/21978/bell-by-nicubunu>

<http://openclipart.org/detail/191140/brown-vaze-clipart.-by-hatarar205-191140>

<http://openclipart.org/detail/139759/r-is-for-rocket-by-marauder>

## 5.2 Any Way You Spin It – Teacher Notes

### *A Develop Understanding Task*

**Purpose:** The purpose of this task is to develop skills for visualizing solids of revolution generated by rotating two-dimensional objects about an axis. Students should also begin to recognize that a solid of revolution can be thought of as a collection of circular disks, and that cross sections perpendicular to the axis of revolution will always be circular.

**Core Standards Focus:**

**G.GMD.4** Identify the shapes of two-dimensional cross-sections of three-dimensional objects, and identify three-dimensional objects generated by rotations of two-dimensional objects.

**Standards for Mathematical Practice:**

**SMP 7 – Look for and make use of structure**

**Vocabulary:** Students will need to understand that a *solid of revolution* is the three-dimensional shape formed when a two-dimensional object is rotated rapidly about an axis.

**The Teaching Cycle:**

**Launch (Whole Class):**

Use the examples described in the first paragraph of the task to introduce the concept of a solid of revolution. Once you have discussed these examples, assign students to work on questions 1-8 of the task.

**Explore (Small Group):**

Pay attention to how students differentiate the results of revolving the triangle in questions 1 and 3 about the x-axis versus the y-axis, as demonstrated by both their drawings and their written descriptions. Students should recognize that the solid formed in question 1 is a cone, and that the

solid formed in question 3 is a cylinder with a cone removed, and use appropriate formulas to find their volumes.

For questions 6 and 7 listen to how students differentiate between the various planes that are used to slice the solid of revolution that they drew in question 5. For question 6, the cross section is a two-dimensional figure that is symmetric about the  $x$ -axis (see diagram at right). For question 7 the cross sections requested are all circles of various radii, with the cross section at  $x = 5$  having the largest radius (5 units) and the cross section at  $x = 10$  having the smallest radius (approximately 2.5 units). Make sure that students know how to determine the radii of these circular cross sections.

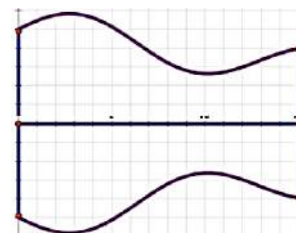

Question 8 requires students to visualize the two-dimensional shape that defines each solid of revolution shown, where these shapes are familiar images. If students are having difficulty with this, show them an example of a crepe-paper holiday decoration, such as a bell or pumpkin, that starts as a flat object, but opens up to form the desired three-dimensional object. (Such decorations can be purchased at most craft stores.)

**Discuss (Whole Class):**

Share student drawings and descriptions as needed, based on your observations of students' thinking and possible misconceptions.

Have students present their work on questions 2 and 4, including descriptions of how they determined the radius and height of the solids of revolution formed by rotating the triangle about the  $x$  and  $y$ -axes.

**Aligned Ready, Set, Go: Modeling with Geometry 5.2**

<b>READY, SET, GO!</b>	Name _____	Period _____	Date _____
------------------------	------------	--------------	------------

**READY**

Topic: Finding the trigonometric ratios in a right triangle

Use the given measures on the triangles to write the indicated trig value.

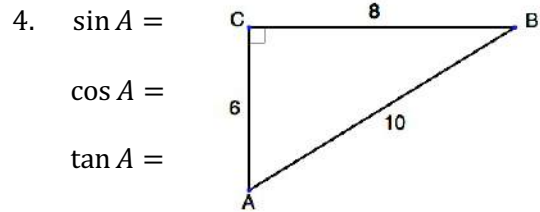
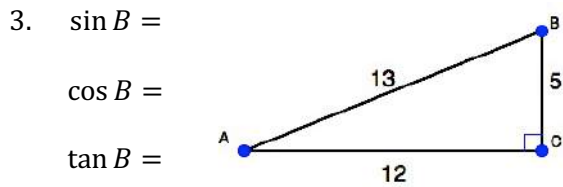
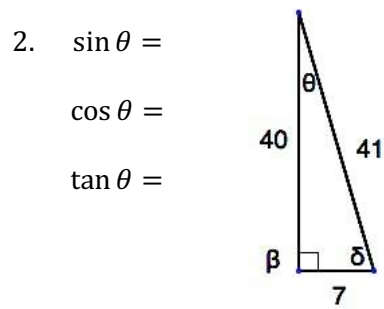
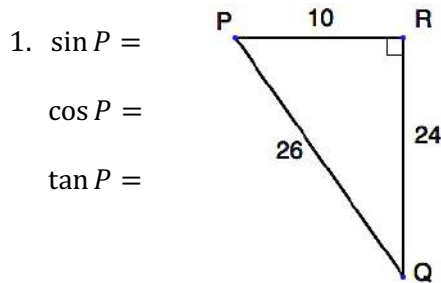

**SET**

Topic: Drawing solids of revolution

For each of the following solids, draw the two-dimensional shape that would be revolved about the x-axis to generate it.

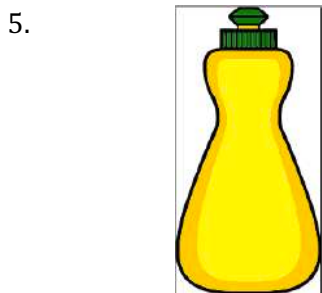

Need help? Visit [www.rsgsupport.org](http://www.rsgsupport.org)

6.



7.

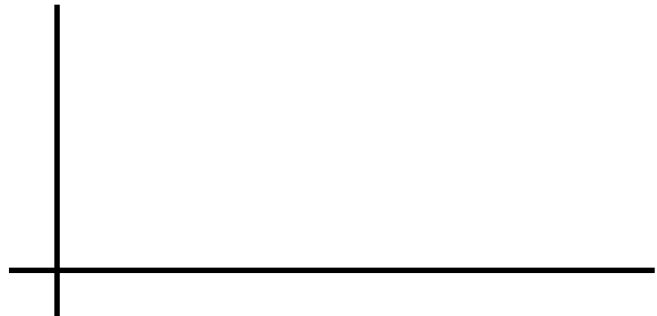
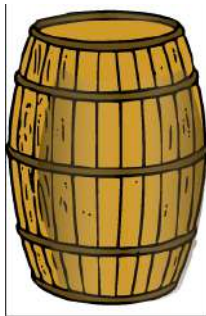

8.



Images used above:

<http://openclipart.org/detail/174126/dish-detergent-bottle-by-tikigiki-174126>

<http://openclipart.org/detail/190246/snow-man-with-hat-by-tiothy-190246>

<http://openclipart.org/detail/167894/barrel-rendered-by-kevie>

[http://openclipart.org/detail/1638/flashlight-by-johnny\\_automatic](http://openclipart.org/detail/1638/flashlight-by-johnny_automatic)

**Need help? Visit [www.rsgsupport.org](http://www.rsgsupport.org)**

Mathematics Vision Project

Licensed under the Creative Commons Attribution CC BY 4.0

[mathematicsvisionproject.org](http://mathematicsvisionproject.org)

9. Name something in your house that would be shaped like the solid of revolution formed, if the figure on the right were rotated about the x-axis.

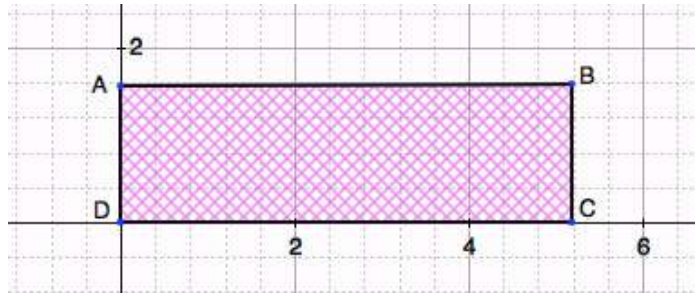

10. Name something in the world that would be shaped like the solid of revolution formed if the figure on the right were rotated about the y-axis.

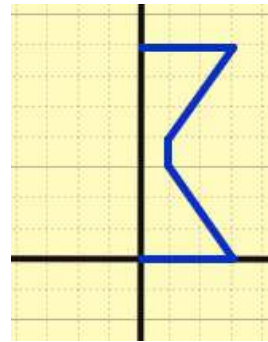

GO

Topic: Using formulas to find the volume of a solid

Find the volume of the indicated solid.

11.  $V = \pi r^2 h$  cylinder

$r = 3$  inches  
 $h = 10$  inches

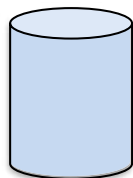

12.  $V = \frac{1}{3}BH$  right circular cone

$r = 8$  cm  
 $H = 20$  cm

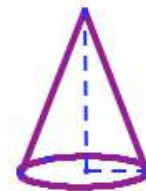

13.  $V = \frac{1}{3}l^2 h$  square pyramid

$h = \frac{5\sqrt{2}}{2}$  m

$l = 3\sqrt{5}$  m

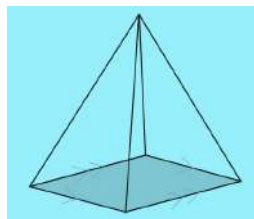

The base is a square.

14.  $V = \frac{1}{3}h(a^2 + ab + b^2)$  square frustum

Where  $a$  and  $b$  are the base and top side lengths and  $h$  is the height

$h = 12$  in  
 $a = 5\sqrt{7}$  in  
 $b = 2\sqrt{7}$  in

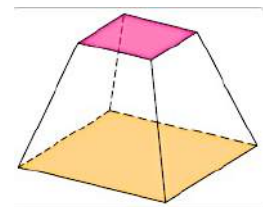

Need help? Visit [www.rsgsupport.org](http://www.rsgsupport.org)

## 5.3 Take Another Spin

### *A Solidify Understanding Task*

The trapezoid shown below is revolved about the  $y$ -axis to form a frustum (e.g., bottom slice) of a cone.



CC BY ieshraq the potter  
<https://flic.kr/p/7r4myS>

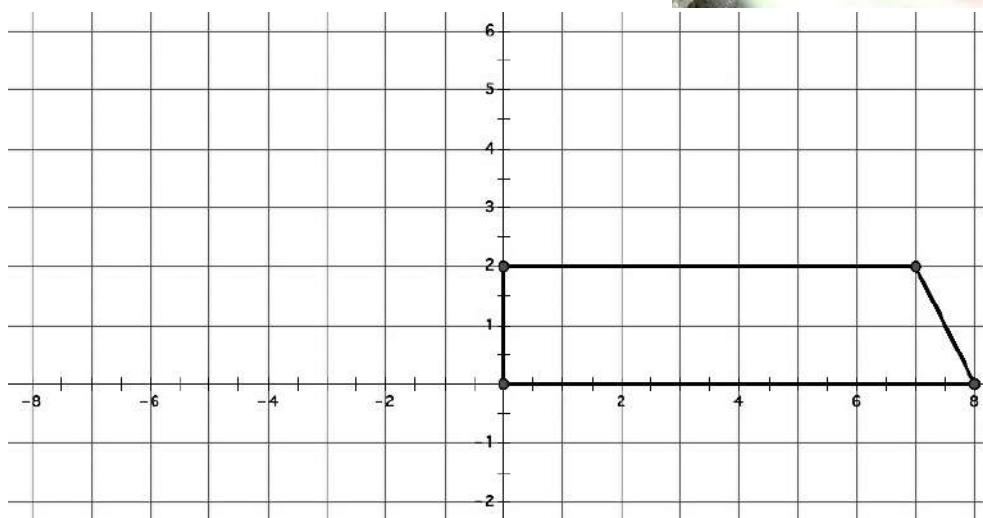

1. Draw a sketch of the three-dimensional object formed by rotating the trapezoid about the  $y$ -axis.
2. Find the volume of the object formed. Explain how you used the diagram to help you find the volume.

You have made use of the formulas for cylinders and cones in your work with solids of revolution. Sometimes a solid of revolution cannot be decomposed exactly into cylinders and cones. We can approximate the volume of solids of revolution whose cross sections include curved edges by replacing them with line segments.

3. The following diagram shows the cross section of a flower vase. Approximate the volume of the vase by using line segments to approximate the curved edges. (Show the line segments you used to approximate the figure on the diagram.)

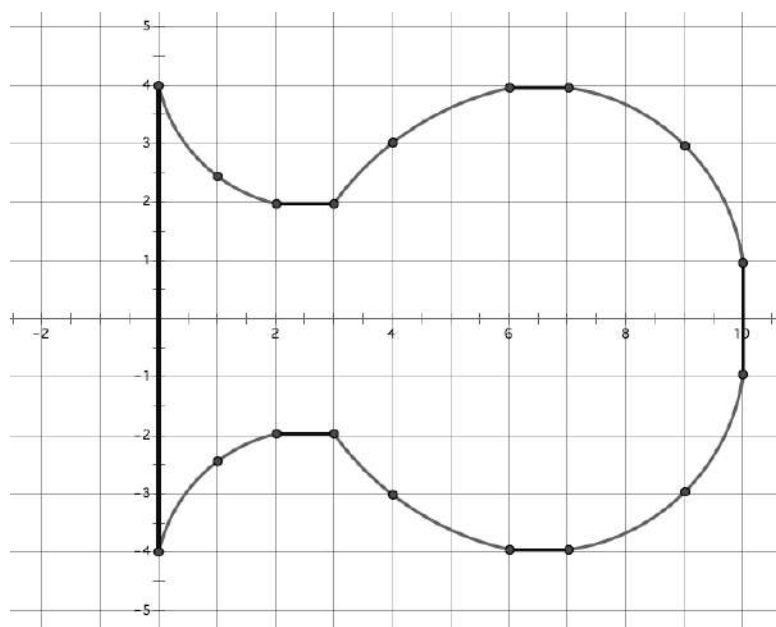

4. Describe and carry out a strategy that will improve your approximation for the volume of the vase.



## 5.3 Take Another Spin – Teacher Notes

### *A Solidify Understanding Task*

**Purpose:** In this task students examine another solid of revolution—a frustum—and create a strategy for finding its volume. They then use a variety of strategies to decompose a figure that consists of curved edges into cylinders, frustums and cones to generate a sequence of better and better approximations of the actual volume of the solid.

**Core Standards Focus:**

**G.MG.1** Use geometric shapes, their measures, and their properties to describe objects (e.g., modeling a tree trunk or a human torso as a cylinder).★

**G.GMD.4** Identify the shapes of two-dimensional cross-sections of three-dimensional objects, and identify three-dimensional objects generated by rotations of two-dimensional objects.

**Standards for Mathematical Practice:**

**SMP 7 – Look for and make use of structure**

**The Teaching Cycle:**

**Launch (Whole Class):**

Introduce the geometric object called a *frustum* as defined in the task. Students should then go right to work on this task, using the idea of a solid of revolution that was introduced in the previous task.

**Explore (Small Group):**

On questions 1 and 2, students will need to be able to visualize this solid of revolution as a slice off of the bottom of a cone. Listen for strategies students use to find the volume of this solid. They may

recognize that they can find the volume of the cone of which this solid is a slice, and then remove the volume of a smaller cone from the top of this larger cone, leaving just the volume of the frustum. Even after they have described a strategy for finding the volume of the frustum, they may not be able to carry out the strategy in this particular case since the height of the cones are not given. Ask how they might use the diagram to determine the height of the larger cone. Students might use the slope of the lateral edge of the frustum to write an equation of a line that would represent the lateral edge of the larger cone, and then find the height of the cone by finding the  $y$ -intercept of this line. If possible, let students figure out this or a similar strategy on their own.

On question 3, watch for the strategies students use to approximate the outer edges of the vase. For example, part of the vase could be approximated with a line generating a frustum, and the remainder of the vase as a horizontal line generating a cylinder, such as in the diagram at the right. Look for a range of strategies for approximating the volume from this strategy, which involves two geometric solids, to a strategy involving many geometric solids. (See diagram below.)

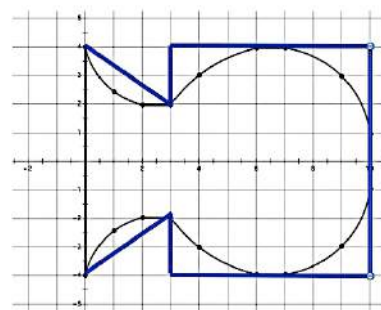

**Discuss (Whole Class):**

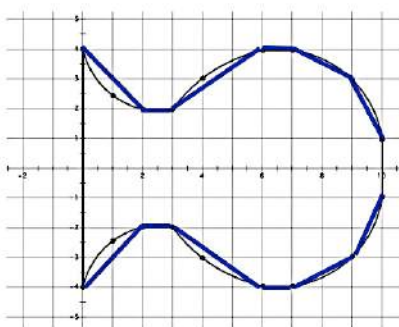

If all students have successfully figured out how to find the volume of the frustum in question 1 you can begin the discussion with question 3. Allow multiple students to show how they decomposed the vase into smaller geometric solids, starting with a simple decomposition and ending with a sophisticated strategy, such as the one illustrated in the figure at the left.

Compare the various approximations, and ask students to consider slicing the solid into a stack of circular disks every  $\frac{1}{2}$  unit along the horizontal axis. Have a student illustrate what this image

would look like. You may want to challenge students to build such an approximation by cutting circles out of cardboard and gluing them together in order.

**Aligned Ready, Set, Go: Modeling with Geometry 5.3**

READY, SET, GO!
Name \_\_\_\_\_
Period \_\_\_\_\_
Date \_\_\_\_\_

**READY**

Topic: Finding missing angles in a triangle

Use the given information and what you know about triangles to find the missing angles.

(All angle measures are in degrees.)

1.

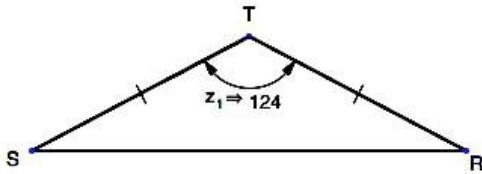

2.

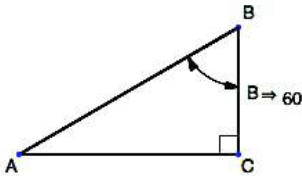

3.

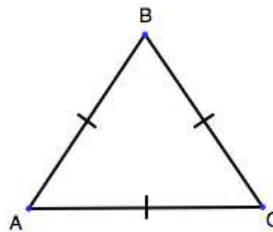

4.

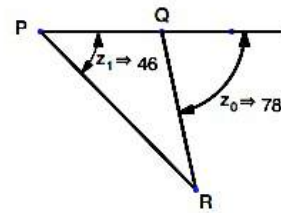

5.

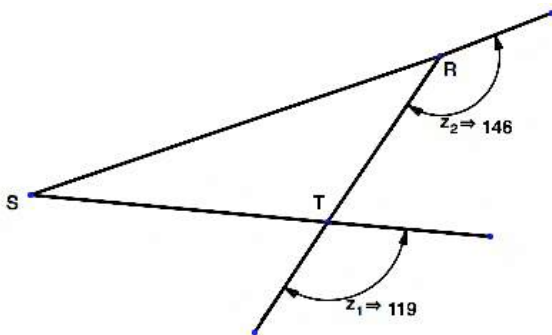

6.  $\overline{EG} \cong \overline{FH}$

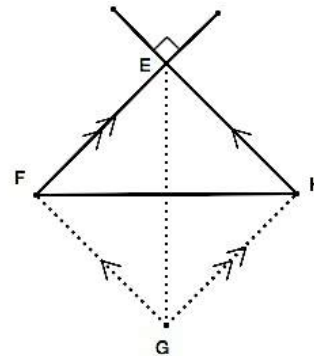

7.

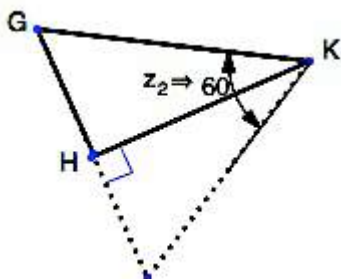

8.

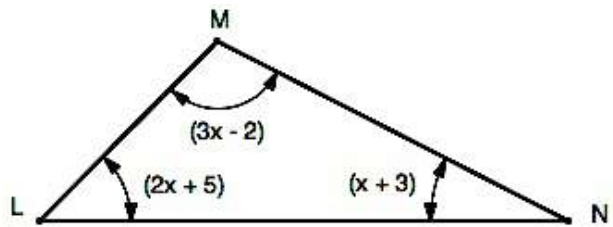

Visit [www.mathematicsvisionproject.org](http://www.mathematicsvisionproject.org)

**SET**

Topic: Calculating the surface area and volumes of combined shapes.

**Answer the following questions about the Washington Monument.**

The picture at the right is of the Washington Monument in DC. The shaft of the monument is a square frustum. The bottom square measures 55 ft. on a side and the top square measures 34.5 feet. The top is a square pyramid.

9. Find the dimensions of the 4 triangular faces of the pyramid.  
 (Height is 55.5 ft)

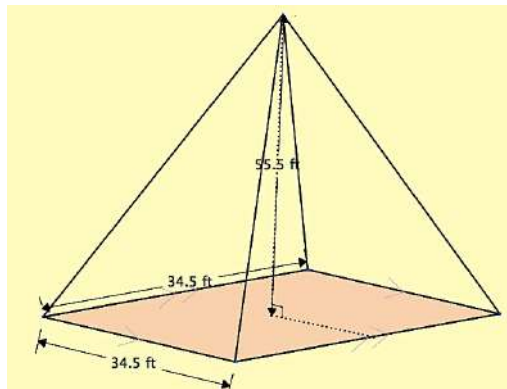

<https://flic.kr/p/axqjPQ>

10. Find the area of each face of the pyramid.  
 11. Find the area of the 4 trapezoids that make the faces of the frustum.

The area of a trapezoid:  $A = \frac{b_1 + b_2}{2} h$

12. Find the total surface area of the Washington Monument.  
 13. Find the total volume of the Washington Monument.

Volume of a square frustum:  $V = \frac{1}{3}h(a^2 + ab + b^2)$  where  $a$  and  $b$  are the side lengths of each square.

Volume of pyramid:  $V = \frac{1}{3}l^2h$

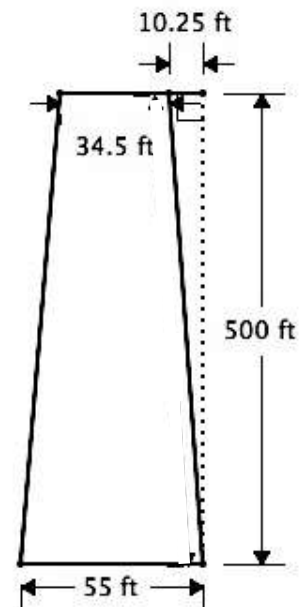

Need help? Visit [www.rsgsupport.org](http://www.rsgsupport.org)

14. Draw a sketch of the three-dimensional object formed by rotating the figure about the  $x$ -axis.

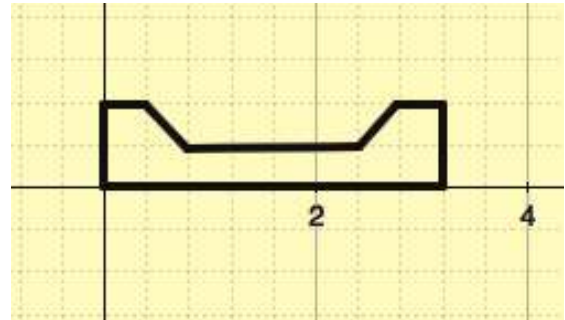

**GO**

Topic: Solving for missing sides in a right triangle

Calculate the missing sides in the right triangle. Give your answers in simplified radical form.

15.



16.

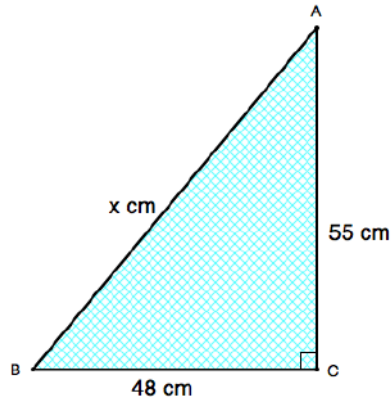

17.

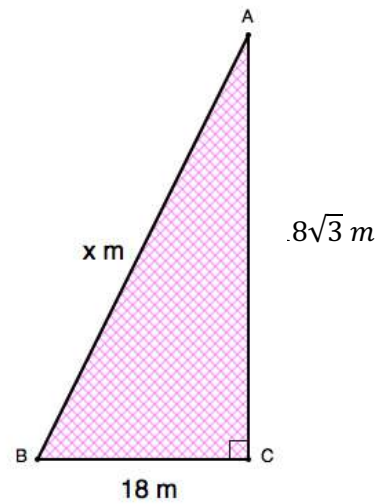

18.

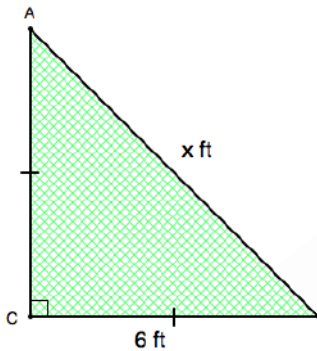

19.

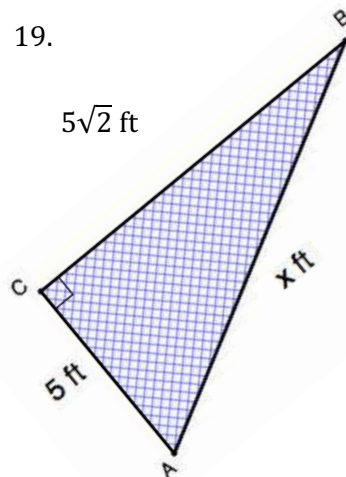

20.

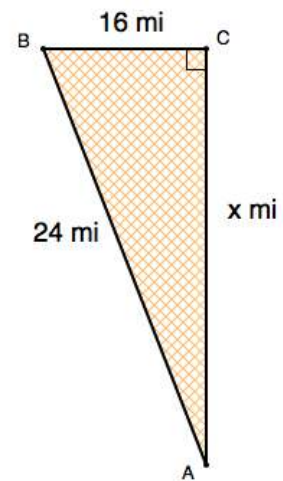

Need help? Visit [www.rsgsupport.org](http://www.rsgsupport.org)

## 5.4 You Nailed It!

### *A Practice Understanding Task*

Tatiana is helping her father purchase supplies for a deck he is building in their back yard. Based on her measurements for the area of the deck, she has determined that they will need to purchase 24 decking planks. These planks will be attached to the framing joists with 16d nails. (Tatiana thinks it is strange that these nails are referred to as “16 penny nails” and wonders where that way of naming nails comes from. After doing some research she has found that in the late 1700s in England the size of a nail was designated by the price of purchasing one hundred nails of that size. She doubts that her dad will be able to buy one hundred 16d nails for 16 pennies.)



CC BY Martin Pettitt  
<https://flic.kr/p/TKh4gH>

Nails are sold by the pound at the local hardware store, so Tatiana needs to figure out how many pounds of 16d nails to tell her father to buy. She has gathered the following information.

- The deck requires 24 decking planks
- Each plank requires 9 nails to attach it to the framing joists
- 16d nails are made of steel that has a density of  $4.67 \text{ oz/in}^3$
- There are 16 ounces in a pound

Tatiana has also found the following drawing of a cross section of a 16d nail. She knows she can use this drawing to help her find the volume of the nail, treating it as a solid of revolution. (Note: The scale on the  $x$ - and  $y$ -axis is in inches.)

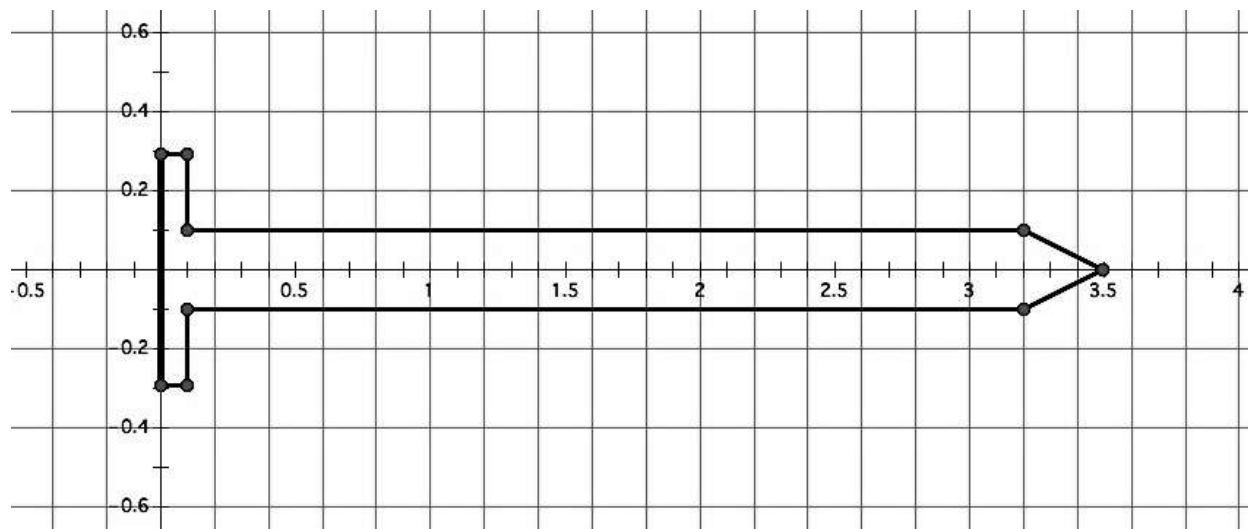

1. Devise a plan for finding the volume of the nail based on the given drawing. Describe your plan in words, and then show the computations that support your work.

2. Devise a plan for finding the number of pounds of 16d nails Tatiana's father should buy. Describe your plan in words, and then show the computations that support your work.



## 5.4 You Nailed It! – Teacher Notes

### *A Practice Understanding Task*

**Purpose:** This task provides an opportunity for students to solidify their understanding of solids of revolution in a problem-solving, modeling context. Students will decompose a geometric solid of revolution into familiar three-dimensional objects whose volumes can be calculated. Students will also need to draw upon their ability to reason with units when solving problems.

**Core Standards Focus:**

**G.MG.1** Use geometric shapes, their measures, and their properties to describe objects (e.g., modeling a tree trunk or a human torso as a cylinder).★

**G.MG.2** Apply concepts of density based on area and volume in modeling situations (e.g., persons per square mile, BTUs per cubic foot).★

**G.MG.3** Apply geometric methods to solve design problems (e.g., designing an object or structure to satisfy physical constraints or minimize cost; working with typographic grid systems based on ratios).★

**Related Standards: N.Q.1.**

**Standards for Mathematical Practice:**

**SMP 2 – Reason abstractly and quantitatively**

**SMP 4 – Model with mathematics**

**Vocabulary:** Students need to understand that the quantity *density* is a derived quantity that represents the weight per unit of volume of the nails, in this case measured in ounces per cubic inch.

**The Teaching Cycle:**

**Launch (Whole Class):**

Discuss the problem-solving scenario of this task, and make sure that students understand the question they are trying to answer. This is a multi-step problem, so emphasize the need with students to devise a plan for carrying out their work.

**Explore (Small Group):**

Listen for how students plan to approach the work of problems 1 and 2:

For problem 1, students will need to decompose the nail into three familiar shapes: the disk (“flat” cylinder) that forms the top of the nail, the cylinder that forms the length of the nail, and the cone that forms the point of the nail. They will need to calculate the volume of each of these shapes by using the grid to give them pertinent information about the radius and height of each object.

Finally, they will need to add the volume of the three shapes together to get the total volume of the nail. For problem 2, students will need to calculate the weight of a 16d nail by multiply its volume by the density of the steel of which it is composed. Once the weight of one nail has been found, they need to multiply by the total number of nails needed for the project. Finally, they need to convert this total weight in ounces to total weight in pounds.

**Discuss (Whole Class):**

Have students share their problem-solving plans and their computational work for questions 1 and 2, as needed. An interesting question to ask students might be, “How much of the total weight of the nails is due to the seemingly insignificant weight of the pointed-tip of the nails?”

**Aligned Ready, Set, Go: Modeling with Geometry 5.4**

<b>READY, SET, GO!</b>	Name _____	Period _____	Date _____
------------------------	------------	--------------	------------

**READY**

Topic: Finding the trigonometric ratios in a right triangle

Use the given measures on the triangle to write the indicated trig value. Write them as a fraction. Then write them as a decimal rounded to the thousandths place.

1.  $\sin A =$   
 $\cos A =$   
 $\tan A =$

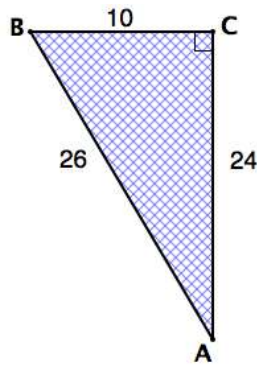

2.  $\sin B =$   
 $\cos B =$   
 $\tan B =$

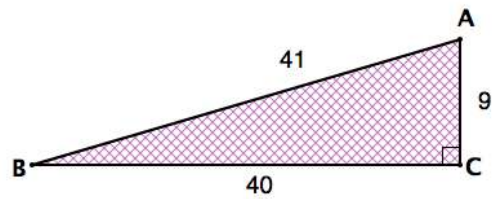

3.  $\sin P =$   
 $\cos P =$   
 $\tan P =$

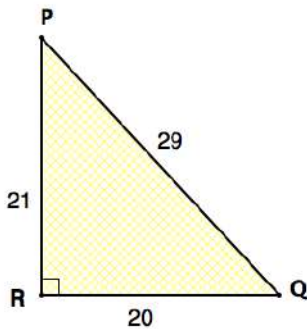

4.  $\sin S =$   
 $\cos S =$   
 $\tan S =$

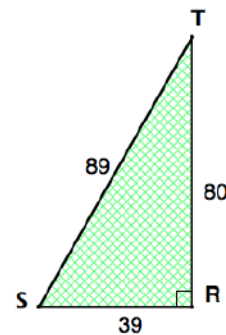

5. Which trigonometric ratio is **exact**, the fraction or the decimal? Explain.

6. My calculator tells me that  $\frac{\sqrt{2}}{2} = 0.7071067812$ . Is one value more accurate than the other? Explain.

Need help? Visit [www.rsgsupport.org](http://www.rsgsupport.org)

**SET**

Topic: Exploring applications of volume, weight and density

**Answer the following questions about the grain stored in the storage silos.**

7. The figure at the right is of 2 grain, storage silos.  
The diameter of each measures 24 feet and the height of the cylinder measures 51 feet. The height of the cone adds an additional 12 feet.  
Find the total volume of one silo.



8. How many bushels of grain will each silo be able to store, if a bushel is 1.244 cubic feet?  
(Assume it can be filled to the top.)
9. Density relates to the degree of compactness of a substance. A cubic inch of gold weighs a great deal more than a cubic inch of wood because gold is more dense than wood. The density of grains also varies. Use the information below to calculate how many tons of each grain can be stored in one silo. (1 ton = 2000 lbs.)
- 1 bushel of oats weighs 32 pounds
- 1 bushel of barley weighs 48 pounds
- 1 bushel of wheat weighs 60 pounds
10. A  $\frac{3}{4}$ -ton pickup has the capacity to haul a little more than 1500 lbs. If the hauling bed of the pickup measures 4 ft. by 6.5 ft. by 2 ft., can a  $\frac{3}{4}$ -ton pickup safely haul a full (level) load of oats, barley, or wheat? Justify your answer for each type of grain.

**Need help?** Visit [www.rsgsupport.org](http://www.rsgsupport.org)

GO

Topic: Forms of linear and quadratic functions

Write what you know about the function (including end-behavior) and then graph it.

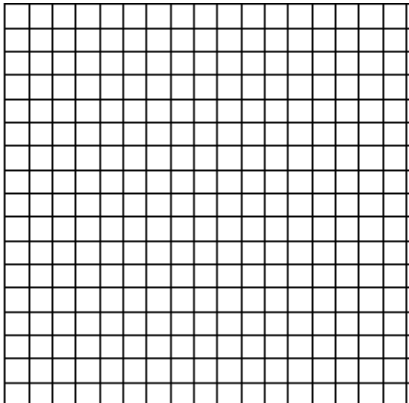
11. Equation: $f(x) = (x - 2)(x + 3)$	Graph:
What I know about this function:  End behavior: as $x \rightarrow -\infty$ , $f(x) \rightarrow$ ____ as $x \rightarrow \infty$ , $f(x) \rightarrow$ ____	

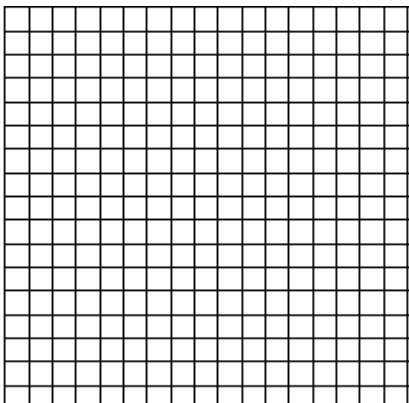
12. Equation: $g(x) = x^2 + 6x + 9$	Graph:
What I know about this function:  End behavior: as $x \rightarrow -\infty$ , $f(x) \rightarrow$ ____ as $x \rightarrow \infty$ , $f(x) \rightarrow$ ____	

Need help? Visit [www.rsgsupport.org](http://www.rsgsupport.org)

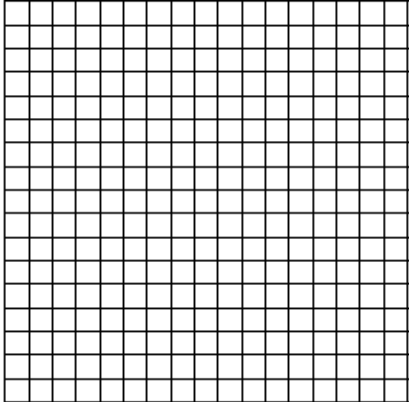
13.	Equation: $y = -x^2 - 4$	Graph:
What I know about this function:		
End behavior: as $x \rightarrow -\infty$ , $f(x) \rightarrow \underline{\hspace{2cm}}$ as $x \rightarrow \infty$ , $f(x) \rightarrow \underline{\hspace{2cm}}$		

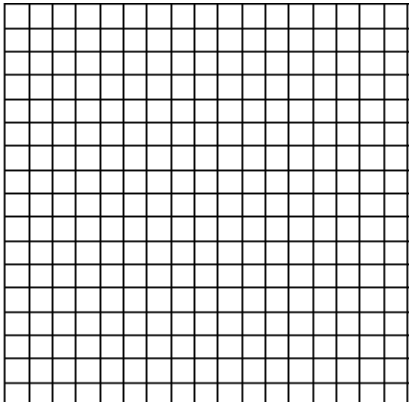
14.	Equation: $h(x) = 2(x - 5) + 3$	Graph:
What I know about this function:		
End behavior: as $x \rightarrow -\infty$ , $f(x) \rightarrow \underline{\hspace{2cm}}$ as $x \rightarrow \infty$ , $f(x) \rightarrow \underline{\hspace{2cm}}$		

Need help? Visit [www.rsgsupport.org](http://www.rsgsupport.org)

## 5.5 Special Rights

### *A Solidify Understanding Task*

In previous courses you have studied the Pythagorean theorem and right triangle trigonometry.

Both of these mathematical tools are useful when trying to find missing sides of a right triangle.

1. What do you need to know about a right triangle in order to use the Pythagorean theorem?
2. What do you need to know about a right triangle in order to use right triangle trigonometry?

While using the Pythagorean theorem is fairly straight forward (you only have to keep track of the legs and hypotenuse of the triangle), right triangle trigonometry generally requires a calculator to look up values of different trig ratios. There are some right triangles, however, for which knowing a side length and an angle is enough to calculate the value of the other sides without using trigonometry. These are known as *special right triangles* because their side lengths can be found by relating them to another geometric figure for which we know something about its sides.

One type of special right triangle is a  $45^\circ$ - $45^\circ$ - $90^\circ$  triangle.

3. Draw a  $45^\circ$ - $45^\circ$ - $90^\circ$  triangle and assign a specific value to one of its sides. (For example, let one of the legs measure 5 cm, or choose to let the hypotenuse measure 8 inches. You will want to try both approaches to perfect your strategy.) Now that you have assigned a measurement to one of the sides of your triangle, find a way to calculate the measures of the other two sides. As part of your strategy, you may want to relate this triangle to another geometric figure that may be easier to think about.



CC BY Phil Roeder  
<https://flic.kr/p/9rasVva>

4. Generalize your strategy by letting one side of the triangle measure  $x$ . Show how the measure of the other two sides can be represented in terms of  $x$ . (Make sure to consider cases where  $x$  is the length of a leg, as well as the case where  $x$  is the length of the hypotenuse.)

Another type of special right triangle is a  $30^\circ$ - $60^\circ$ - $90^\circ$  triangle.

5. Draw a  $30^\circ$ - $60^\circ$ - $90^\circ$  triangle and assign a specific value to one of its sides. Now that you have assigned a measurement to one of the sides of your triangle, find a way to calculate the measures of the other two sides. As part of your strategy, you may want to relate this triangle to another geometric figure that may be easier to think about.
6. Generalize your strategy by letting one side of the triangle measure  $x$ . Show how the measure of the other two sides can be represented in terms of  $x$ . (Make sure to consider cases where  $x$  is the length of a leg, as well as the case where  $x$  is the length of the hypotenuse.)
7. Can you think of any other angle measurements that will create a special right triangle?



## 5.5 Special Rights – Teacher Notes

### *A Solidify Understanding Task*

**Purpose:** This task allows students the opportunity to review previous work with right triangles using the Pythagorean theorem and right triangle trigonometry in preparation for the next task in this module where they will find ways to determine unknown measurements in non-right triangles. In this task students will develop relationships between the lengths of the sides of  $45^\circ$ - $45^\circ$ - $90^\circ$  triangles and  $30^\circ$ - $60^\circ$ - $90^\circ$  triangles, in preparation for finding exact values for the coordinates of points on the unit circle in Secondary Math III.

**Core Standards Focus:**

**G.SRT.11 (+)** Understand and apply the Law of Sines and the Law of Cosines to find unknown measurements in right and non-right triangles (e.g., surveying problems, resultant forces).

**Standards for Mathematical Practice:**

**SMP 7 – Look for and make use of structure**

**SMP 8 – Look for and express regularity in repeated reasoning**

**Vocabulary:** By the end of the task make sure that students understand why the 30-60-90 and 45-45-90 triangles are referred to as special right triangles. Question 7 will aid in this discussion.

**The Teaching Cycle:**

**Launch (Whole Class):**

Give students a few minutes to individually answer questions 1 and 2, and then discuss them as a whole class. Students should be able to identify that to use the Pythagorean theorem we need to know any two sides of the right triangle, and to use right triangle trig we need to know one side and the measure of an acute angle. We select the appropriate trig ratio depending on the given side and the side to be determined.

Once students have reviewed these key issues, read with them the paragraph that describes *special right triangles*, then set students to work on the task.

**Explore (Small Group):**

Questions 3 and 5 ask students to visualize special right triangles as part of another, well-known geometric shape. Do not short-change this visualization by telling students how to “see” these triangles or what to relate them to. Students should be allowed to develop these relationships for themselves, so they will recognize them in the future. For many students it is difficult to *recall* these relationships, but it is easy to *re-derive* them when needed. If needed, prompt students by asking, “What if you put two congruent copies of these triangles together, what shapes might be formed? What can you say about the side lengths in this new figure? What happens to the side lengths when the two copies are pulled apart?”

Listen for students who can present the more general strategies for relating a side of length  $x$  in a special right triangle to the lengths of the other sides. You may prompt this discussion by asking, “If the length of this side is  $x$ , how might we express the length of the other two sides in terms of  $x$ ?”

**Discuss (Whole Class):**

Select a student to present who can relate a  $45^\circ$ - $45^\circ$ - $90^\circ$  triangle to the triangle formed by a diagonal of a square, and then use that image to reason about the lengths of the other two sides. All students should make note of both of the following possible scenarios, and be able to derive the other sides based on the side whose length is  $x$ .

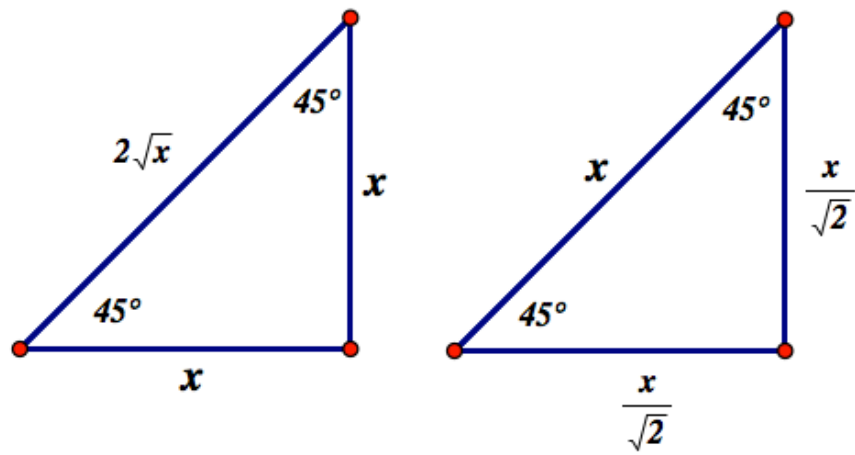

Select a student to present who can relate a 30°-60°-90° triangle to the triangle formed by an altitude of an equilateral triangle, and then use that image to reason about the lengths of the other two sides. All students should make note of each of the following possible scenarios, and be able to derive the other sides based on the side whose length is  $x$ .

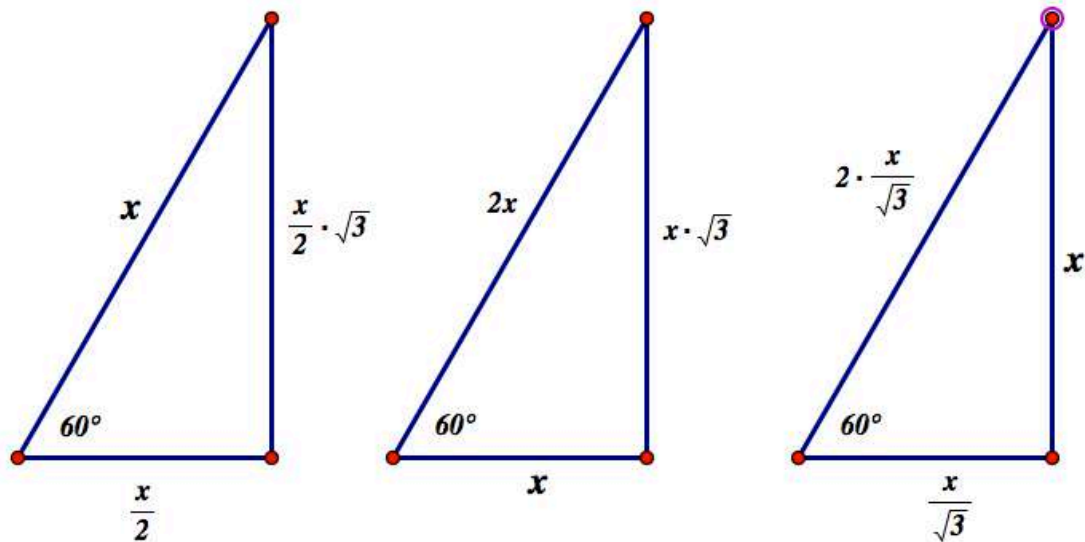

You may wish to discuss the alternative forms of some of these expressions created by rationalizing

the denominator, such as  $\frac{x}{\sqrt{2}} = \frac{\sqrt{2}x}{2}$ ,  $\frac{x}{\sqrt{3}} = \frac{\sqrt{3}x}{3}$  or  $2 \cdot \frac{x}{\sqrt{3}} = \frac{2\sqrt{3}x}{3}$ , as well as writing  $\frac{x}{2} \cdot \sqrt{3}$  as

$\frac{\sqrt{3}x}{2}$ . For each of these equations the expression on the left gives a “rule” for computing the length

of the side from the given side  $x$ , and the expression on the right gives a numerical name for that length.

### **Aligned Ready, Set, Go: Modeling with Geometry 5.5**

READY, SET, GO!

Name

Period

Date

**READY**

Topic: Finding missing measures in triangles

Use the given figure to answer the questions. Round your answers to the hundredths place.

Given:  $m\angle CBD = 51^\circ$   
 $m\angle CDA = 30^\circ$

1. Find  $m\angle BCD$

Given:  $m\angle CAD = 90^\circ$

2. Find  $m\angle BCA$  and  $m\angle ACD$

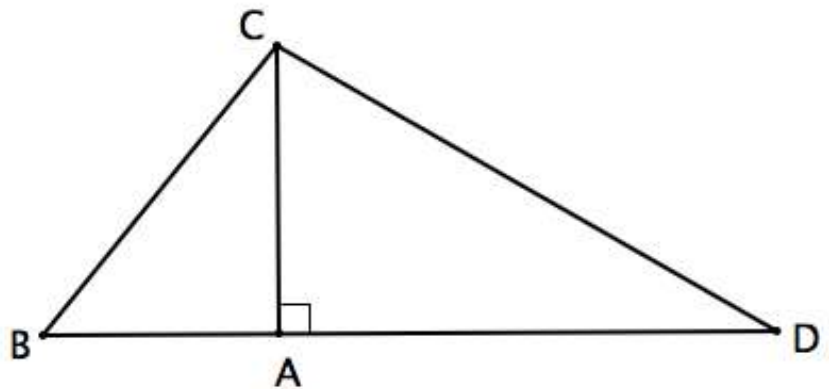

Given:  $CA = 6 \text{ ft}$

3. Find BC

4. Find BA

5. Find CD

6. Find AD

7. Find BD

8. Find the area of  $\triangle BCD$

Need help? Visit [www.rsgsupport.org](http://www.rsgsupport.org)

**SET**

Topic: Recalling triangle relationships in Special Right Triangles

Fill in all the missing measures in the triangles.

9.

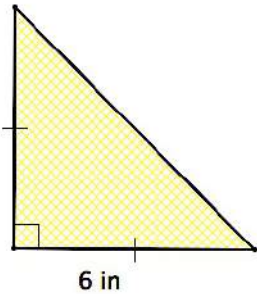

10.

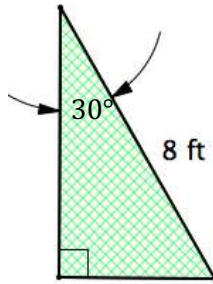

11.

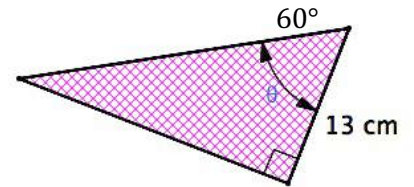

12.

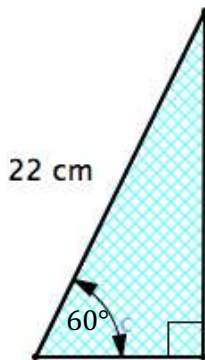

13.

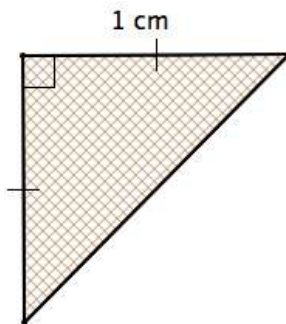

14.

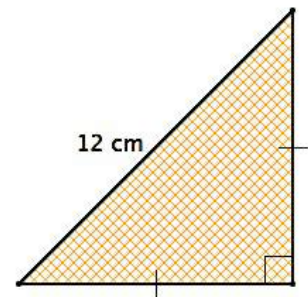

Use an appropriate triangle from above to fill in the function values below. No calculators.

15.

$\sin 45^\circ =$	
$\cos 45^\circ =$	
$\tan 45^\circ =$	

16.

$\sin 30^\circ =$	
$\cos 30^\circ =$	
$\tan 30^\circ =$	

17.

$\sin 60^\circ =$	
$\cos 60^\circ =$	
$\tan 60^\circ =$	

Need help? Visit [www.rsgsupport.org](http://www.rsgsupport.org)

GO

Topic: Performing function arithmetic on a graph

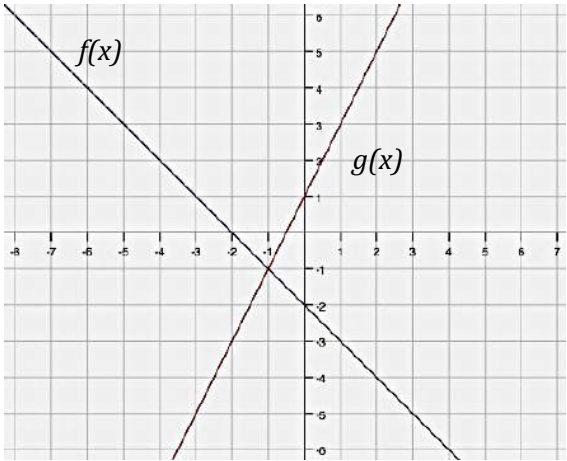
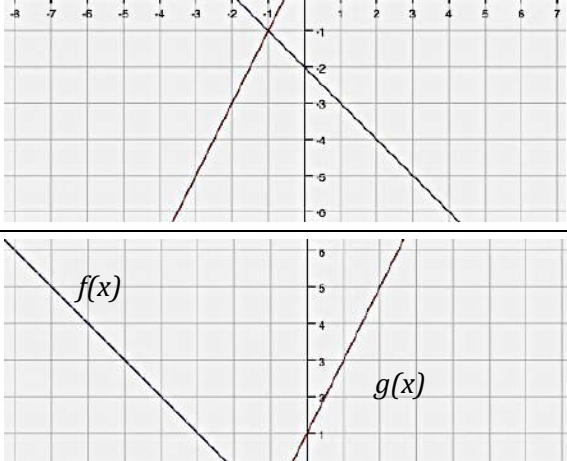
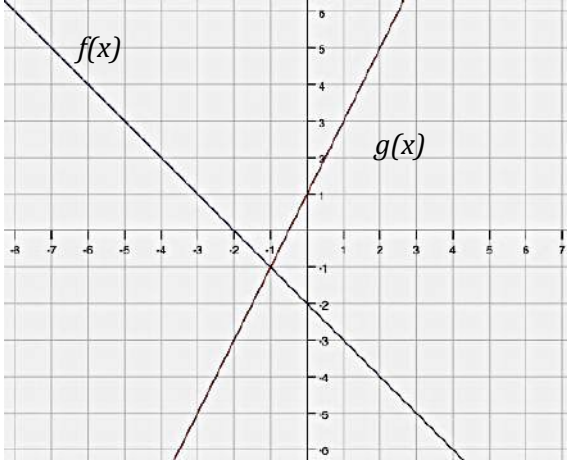
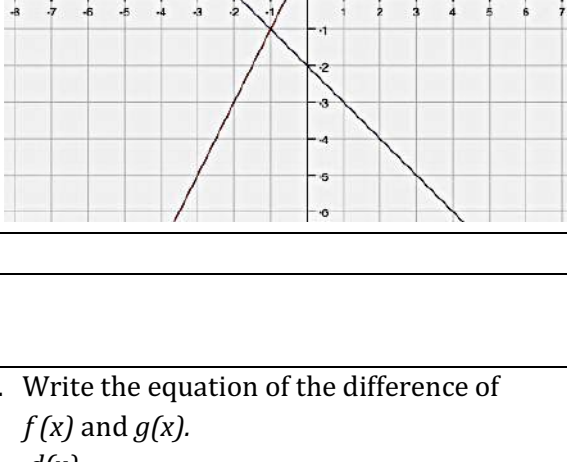
<p>18. Add <math>f(x)</math> and <math>g(x)</math> using the graph at the right.</p> <p>Draw the new figure on the graph and label it as <math>s(x)</math>, the sum of <math>x</math>.</p>	
<p>19. Subtract <math>f(x)</math> from <math>g(x)</math> using the graph at the right.</p> <p>Draw the new figure on the graph and label it as <math>d(x)</math>, the difference of <math>x</math>.</p>	
<p>20. Multiply <math>f(x)</math> and <math>g(x)</math> on the second graph at the right.</p> <p>Draw the new figure on the graph and label it as <math>p(x)</math>, the product of <math>x</math>.</p>	
<p>21. Divide <math>f(x)</math> by <math>g(x)</math> on the second graph at the right.</p> <p>Draw the new figure on the graph and label it as <math>q(x)</math>, the quotient of <math>x</math>.</p>	
<p>22. Write the equations of <math>f(x)</math> and <math>g(x)</math>.</p>	
<p>23. Write the equation of the sum of <math>f(x)</math> and <math>g(x)</math>.  <math>s(x) =</math></p>	<p>24. Write the equation of the difference of <math>f(x)</math> and <math>g(x)</math>.  <math>d(x) =</math></p>
<p>25. Write the equation of the product of <math>f(x)</math> and <math>g(x)</math>.  <math>p(x) =</math></p>	<p>26. Write the equation of the quotient of <math>f(x)</math> divided by <math>g(x)</math>.  <math>q(x) =</math></p>

Need help? Visit [www.rsgsupport.org](http://www.rsgsupport.org)

## 5.6 More Than Right

### A Develop Understanding Task

We can use right triangle trigonometry and the Pythagorean theorem to solve for missing sides and angles in a right triangle. What about other triangles? How might we find unknown sides and angles in acute or obtuse triangles if we only know a few pieces of information about them?

In the previous task we found it might be helpful to create right triangles by drawing an altitude in a non-right triangle. We can then apply trigonometry or the Pythagorean theorem to the smaller right triangles, which may help us learn something about the sides and angles in the larger triangle.

See if you can devise a strategy for finding the missing sides and angles of each of these triangles.

1.

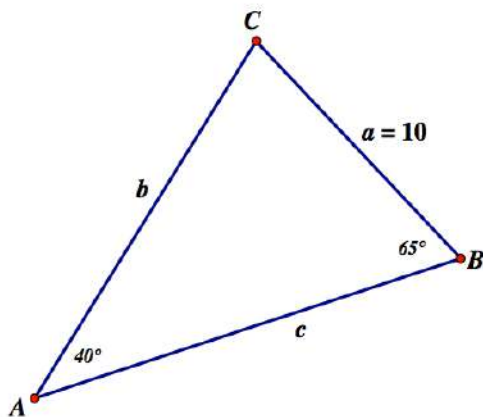

CC BY Daniel X. O'Neil  
<https://flic.kr/p/8hn6x2>



2.

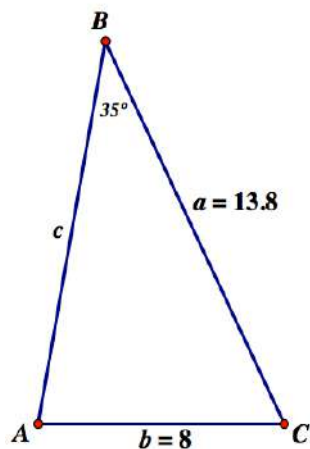

3. See if you can generalize the work you have done on problems 1 and 2 by finding relationships between sides and angles in the following diagram. Unlike the previous two problems, this triangle contains an obtuse angle at  $C$ . Find as many relationships as you can between sides  $a$ ,  $b$  and  $c$  and the related angles  $A$ ,  $B$  and  $C$ .

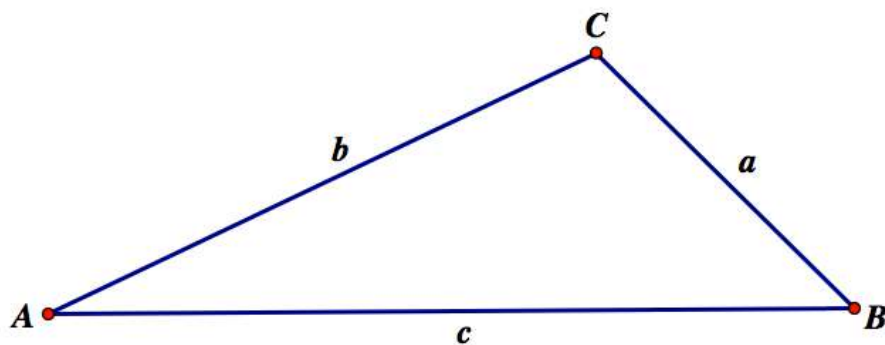

## 5.6 More Than Right – Teacher Notes

### *A Develop Understanding Task*

**Purpose:** Rather than initially giving students the Law of Sines and Law of Cosines, the purpose of this task is to give students opportunities to develop the geometric and algebraic ideas that underpin these two laws. Decomposing a non-right triangle into two right triangles by drawing one of its altitudes is an insightful geometric strategy. Recognizing that an altitude drawn in a non-right triangle can form a leg of two different right triangles—and its length is the same regardless of which right triangle is used to calculate it—is a useful algebraic strategy. In this task, students should be able to find missing sides and angles of non-right triangles using a variety of strategies leading to the development of the Law of Sines and the Law of Cosines that will be formalized in the next task.

**Core Standards Focus:**

**G.SRT.10** (+) Prove the Laws of Sines and Cosines and use them to solve problems.

**G.SRT.11** (+) Understand and apply the Law of Sines and the Law of Cosines to find unknown measurements in right and non-right triangles (e.g., surveying problems, resultant forces).

**Standards for Mathematical Practice:**

**SMP 7 – Look for and make use of structure**

**The Teaching Cycle:**

**Launch (Whole Class):**

Remind students that in the previous task they drew auxiliary lines in geometric figures to relate special right triangles to other shapes. For example, they may have drawn a diagonal in a square to create a  $45^\circ$ - $45^\circ$ - $90^\circ$  right triangle, or the altitude of an equilateral triangle to form a

$30^\circ$ - $60^\circ$ - $90^\circ$  right triangle. Using this strategy they could relate what they knew about the original figure to the new figure formed. With this strategy in mind, set students to work on the rest of the task.

**Explore (Small Group):**

Make sure that students are working with right triangles and not assuming that they can apply the Pythagorean theorem or right triangle trig ratios to the given triangles. Point out this error in thinking and ask how they might form right triangles by drawing additional lines in the triangles.

Listen for how students decide which altitude to draw in each triangle. You may need to ask, "Is there another way to divide this triangle up into smaller right triangles?" Watch for how students attend to the given sides and angles in making their decisions about which altitude to draw and which trig ratios to use.

Select students to present who have potential strategies, even though they may not be fully developed. For example, on problem 1 a student might draw an altitude from vertex  $C$  to side  $AB$  and use the length of side  $a$  and the trig ratio  $\sin B$  to calculate the length of the altitude. Once the length of the altitude is known, the student might use that length along with  $\sin C$  to calculate the length of side  $b$ . However, the student may not know how to find the length of side  $c$ . Listen for other students who may be able to continue the strategy by using cosine ratios to find the length of the two smaller segments on side  $c$ .

Similarly, for problem 2 students may draw one of the altitudes, write some relationships based on right triangle trig or the Pythagorean theorem, but not know how to make use of the relationships they write. Again, watch for how students decide which altitude to draw, and listen for someone who notices that the altitude drawn from vertex  $C$  perpendicular to side  $AB$  provides enough information to calculate the length of this altitude. The length of this altitude can also be expressed

in another way using the equation  $\sin A = \frac{h}{8}$ . Knowing the value of  $h$  allows us to compute the measure of angle  $A$ .

Problem 3 is designed to allow students to generate relationships between the sides and angles of this obtuse triangle. Allow students to explore without imposing any particular agenda. This diagram will be revisited in the next task. Students should recognize that they cannot write any relationships until they first add an altitude to the triangle. They will then be able to write some trig relationships, apply the Pythagorean theorem, and perhaps use substitution or setting two expressions equal to each other to create other relationships.

**Discuss (Whole Class):**

The discussion should focus on strategies for solving the triangles given in 1 and 2. The key strategy was established in the launch: to form right triangles by adding one or more altitudes to the diagram. However, not all altitudes are equally useful. An additional strategy that might emerge is to use an altitude that does not intersect any of the sides whose measurements are known. Another key strategy is to find two different expressions for the length of a segment, particularly the altitude. This allows one to set expressions equal to each other, or substitute one expression into another. One unknown side will always be decomposed into two smaller segments whose lengths can be found individually, and added together to get the length of the third side of the triangle. List these ideas as they emerge in the discussion of questions 1 and 2. Then have students apply these strategies to the diagram in question 3.

**Aligned Ready, Set, Go: Modeling with Geometry 5.6**

READY, SET, GO!

Name \_\_\_\_\_

Period \_\_\_\_\_

Date \_\_\_\_\_

**READY**

Topic: Finding area of triangles

Find the area of each triangle.  $A = \frac{1}{2}bh$

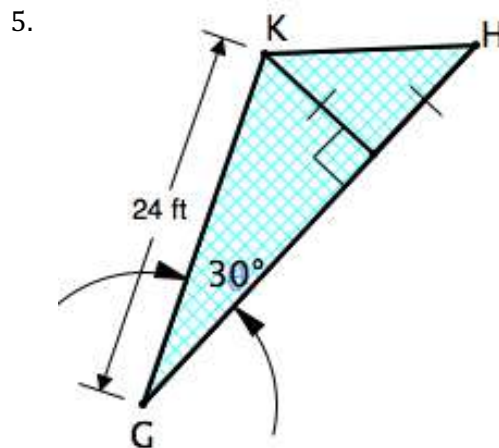
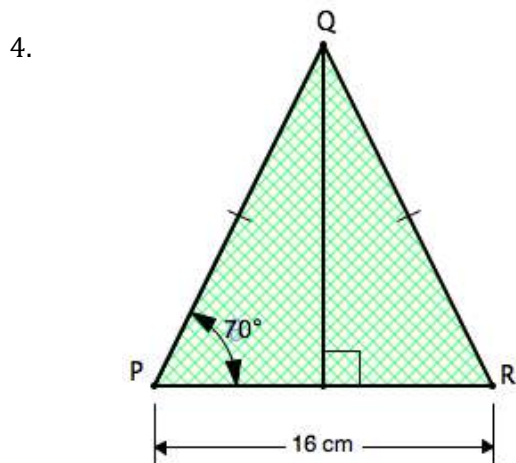
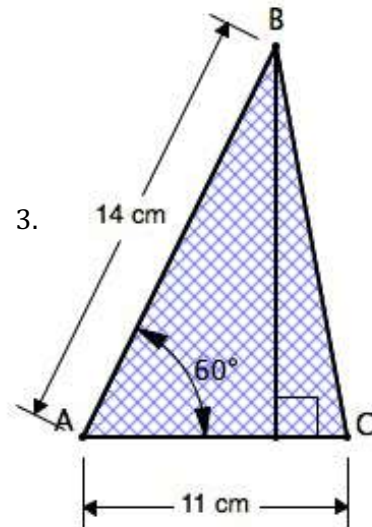
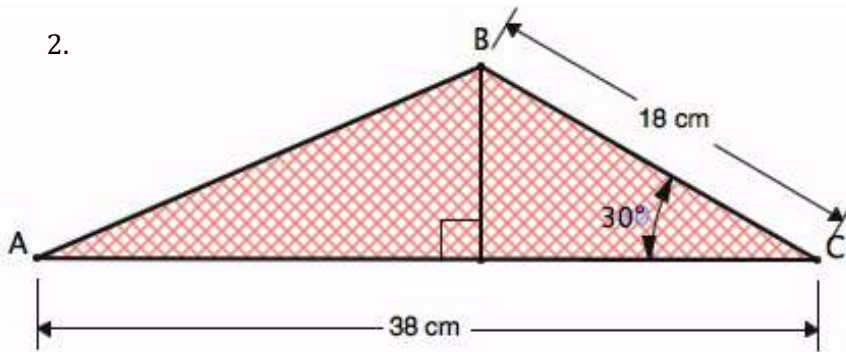
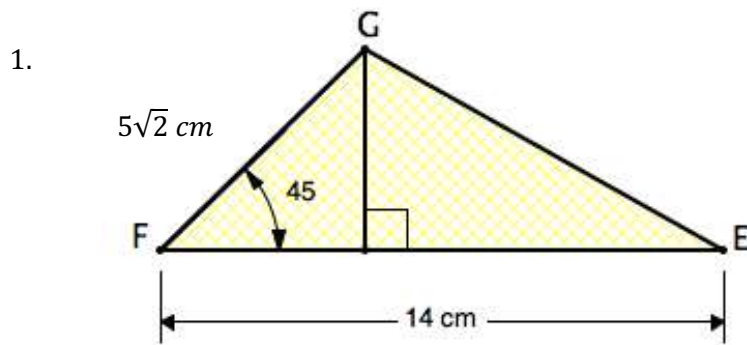

need help? visit [www.rsgsupport.org](http://www.rsgsupport.org)

**SET**

Topic: Using right triangle trig to solve triangles

**Solve the following application problems using right triangle trigonometry.**

6. While traveling across a flat stretch of desert, Joey and Holly make note of a mountain peak in the distance that seems to be directly in front of them. They estimate the angle of elevation to the peak as  $5^\circ$ . After traveling 6 miles towards the mountain the angle of elevation is  $25^\circ$ . Approximate the height of the mountain in miles and in feet. **5,280ft = 1 mile** (While figuring, use at least 4 decimal places.)

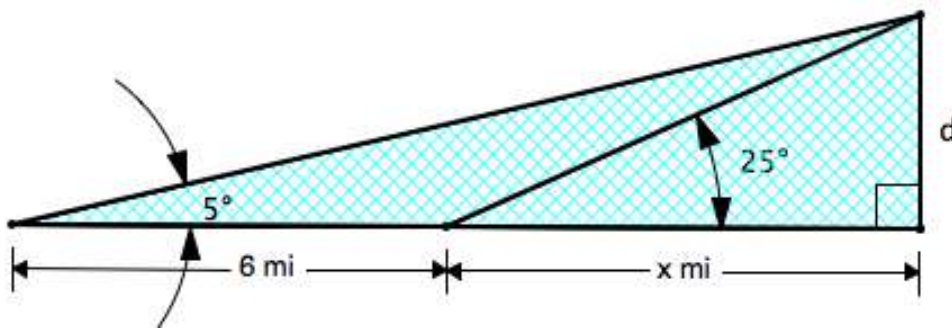

7. The Star Point Ranger Station and the Twin Pines Ranger Station are 30 miles apart along a straight scenic road. Each station gets word of a cabin fire in a remote area known as Ben's Hideout. A straight path from Star Point to the fire makes an angle of  $34^\circ$  with the road, while a straight path from Twin Pines makes an angle of  $14^\circ$  with the road. Find the distance  $d$  of the fire from the road.

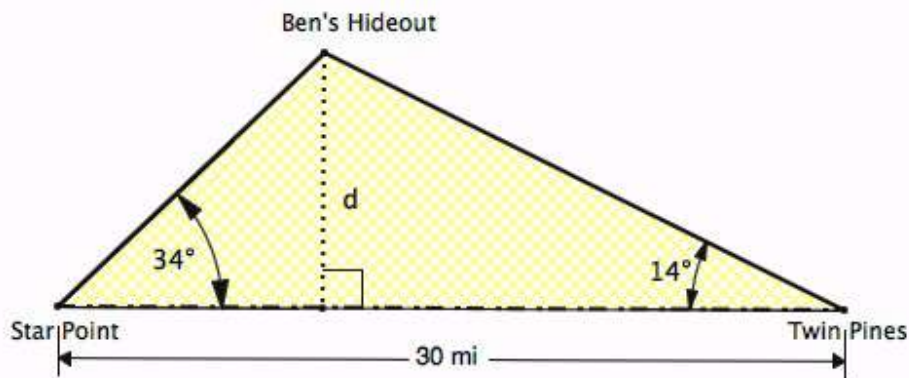

Need help? Visit [www.rsgsupport.org](http://www.rsgsupport.org)

GO

Topic: Recalling measures in special right triangles

Fill in the missing sides and angles in the right triangles. Write answers in simplified radical form. Do NOT use a calculator.

8.

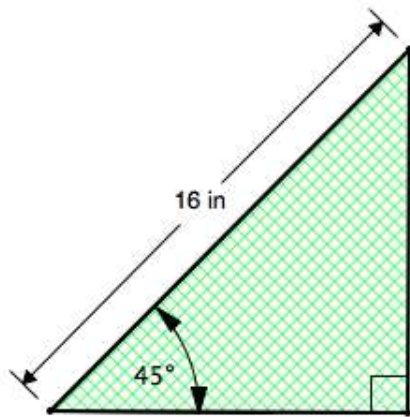

9.

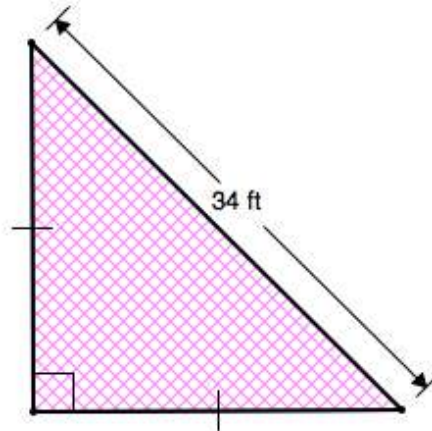

10. Write a rule for finding the sides of an isosceles right triangle when you know the hypotenuse and the measure of the hypotenuse does NOT show a  $\sqrt{2}$ .

11.

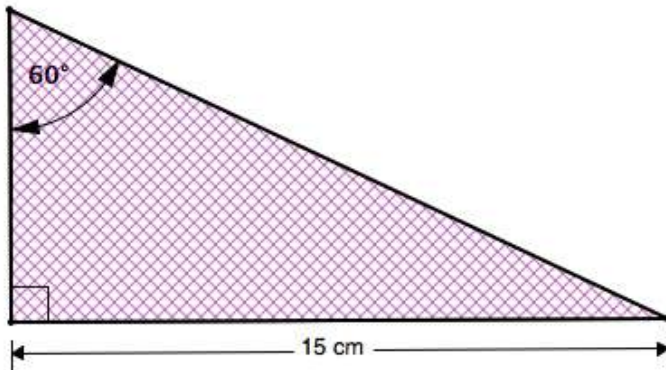

12.

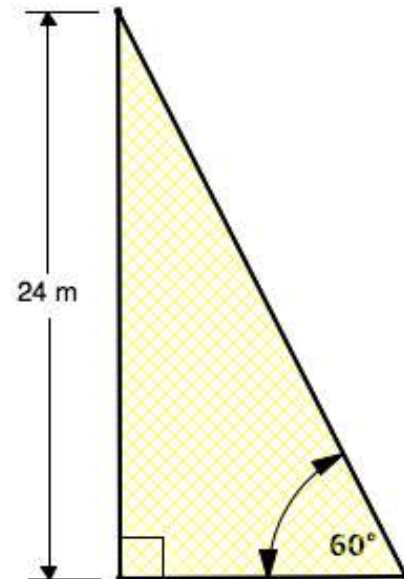

Need help? Visit [www.rsgsupport.org](http://www.rsgsupport.org)



13. Write a rule for finding the missing sides in a  $30^\circ - 60^\circ - 90^\circ$  when you know the side opposite the  $60^\circ$  angle but the measurement doesn't show a  $\sqrt{3}$ .

Fill in the missing measurements.

14.

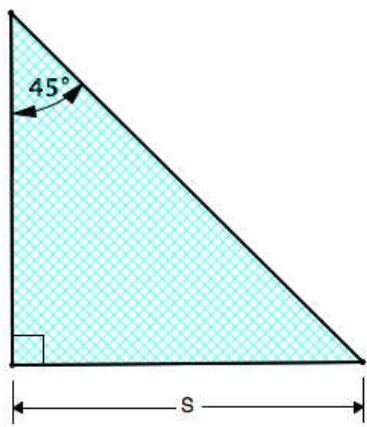

15.

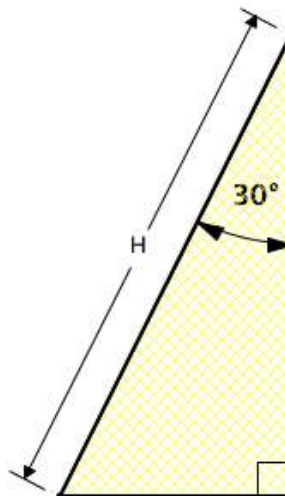

Fill in the ratios for the given functions. Do not use a calculator. Answers should be in simplified radical form.

16.

$\sin 45^\circ =$	
$\cos 45^\circ =$	
$\tan 45^\circ =$	

17.

$\sin 30^\circ =$	
$\cos 30^\circ =$	
$\tan 30^\circ =$	

18.

$\sin 60^\circ =$	
$\cos 60^\circ =$	
$\tan 60^\circ =$	

Need help? Visit [www.rsgsupport.org](http://www.rsgsupport.org)



## 5.7 Justifying the Laws

### A Solidify Understanding Task



CC BY Rumble Press  
<https://flic.kr/p/iASeZ8>

The Pythagorean theorem makes a claim about the relationship between the areas of the three squares drawn on the sides of a right triangle: *the sum of the area of the squares on the two legs is equal to the area of the square on the hypotenuse*. We generally state this relationship algebraically as  $a^2 + b^2 = c^2$ , where it is understood that  $a$  and  $b$  represent the length of the two legs of the right triangle, and  $c$  represents the length of the hypotenuse.

What about non-right triangles? Is there a relationship between the areas of the squares drawn on the sides of a non-right triangle? (Note: The following proof is based on *The Illustrated Law of Cosines*, by Don McConnell <http://www.cut-the-knot.org/pythagoras/DonMcConnell.shtml>)

The diagram on the next page shows an acute triangle with squares drawn on each of the three sides. The three altitudes of the triangle have been drawn and extended through the squares on the sides of the triangle. The altitudes divide each square into two smaller rectangles.

1. Find an expression for the areas of each of the six small rectangles formed by the altitudes. Write these expressions inside each rectangle on the diagram. (Hint: The area of each rectangle can be expressed as the product of the side length of the square and the length of a segment that is a leg of a right triangle. You can use right triangle trigonometry to express the length of this segment.)
2. Although none of the six rectangles are congruent, there are three pairs of rectangles where each rectangle in the pair has the same area. Using three different colors—red, blue and green—shade pairs of rectangles that have the same area with the same color.
3. The area of each square is composed of two smaller, rectangular areas of two different colors. Write three different “equations” to represent the areas of each of the squares. For example, you might write  $a^2 = \text{blue} + \text{red}$  if those are the colors you chose for the areas of the rectangles formed in the square drawn on side  $a$ .

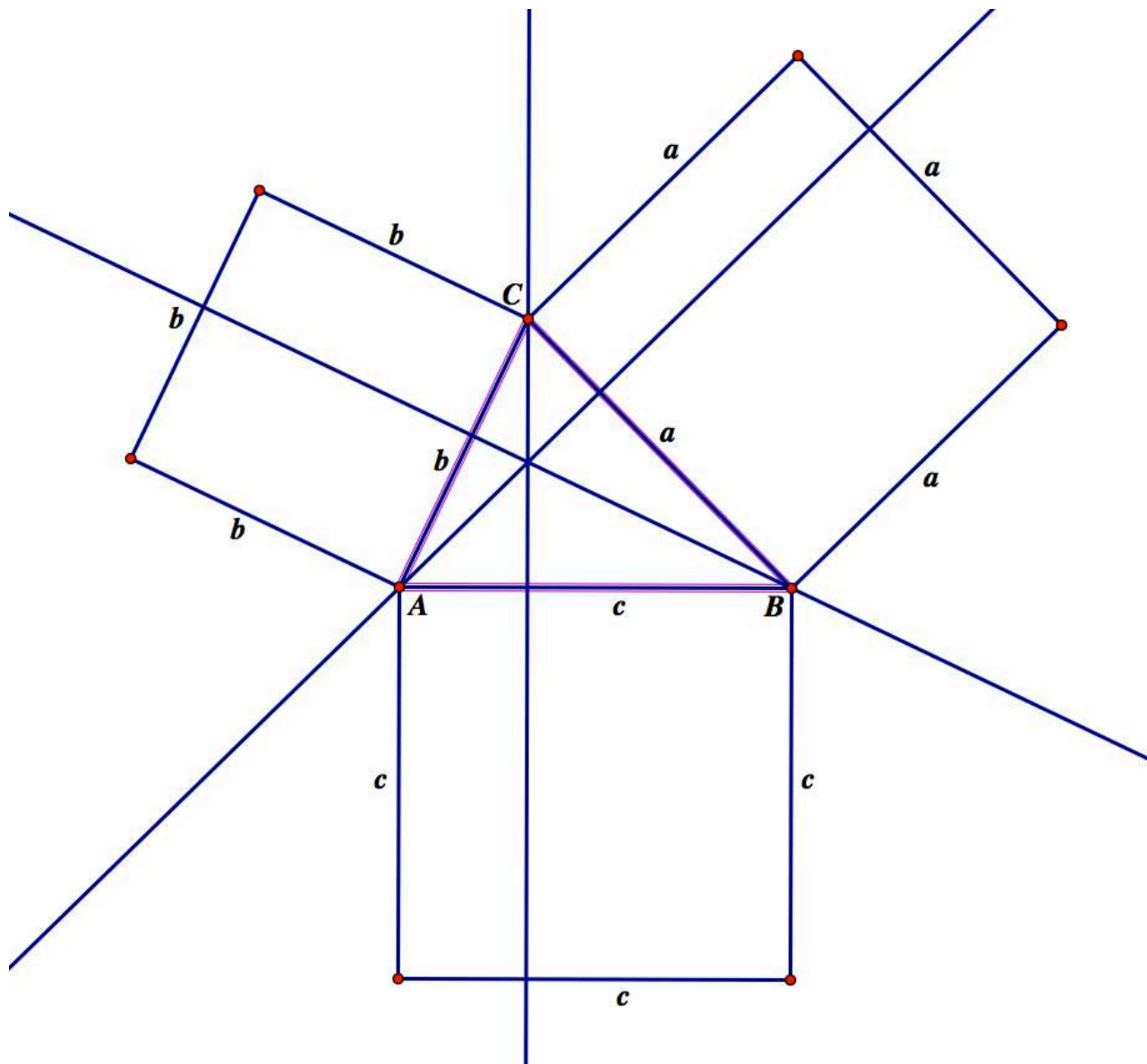

4. Select one of your equations from step 3, such as  $a^2 = \text{blue} + \text{red}$ , and use the other two squares to substitute a different expression in for each color. For example, if in your diagram

$blue = b^2 - green$  and  $red = c^2 - green$ , we can write this equation:  
 $a^2 = b^2 - green + c^2 - green$  or  $a^2 = b^2 + c^2 - 2 \cdot green$ .

Write your selected equation in its modified form here:

5. Since each color is actually a variable representing an area of a rectangle, replace the remaining color in your last equation with the expression that gives the area of the rectangles of that color.

Write your final equation here:

6. Repeat steps 4 and 5 for the other two equations you wrote in step 3. You should end up with three different versions of the **Law of Cosines**, each relating the area of one of the squares drawn on a side of the triangle to the areas of the squares on the other two sides.

$$a^2 =$$

$$b^2 =$$

$$c^2 =$$

7. What happens to this diagram if angle  $C$  is a right angle? (Hint: Think about the altitudes in a right triangle.)
8. Why do we have to subtract some area from  $a^2 + b^2$  to get  $c^2$  when angle  $C$  is less than right?

The Law of Cosines can also be derived for an obtuse triangle by using the altitude of the triangle drawn from the vertex of the obtuse angle, as in the following diagram, where we assume that angle  $A$  is obtuse.

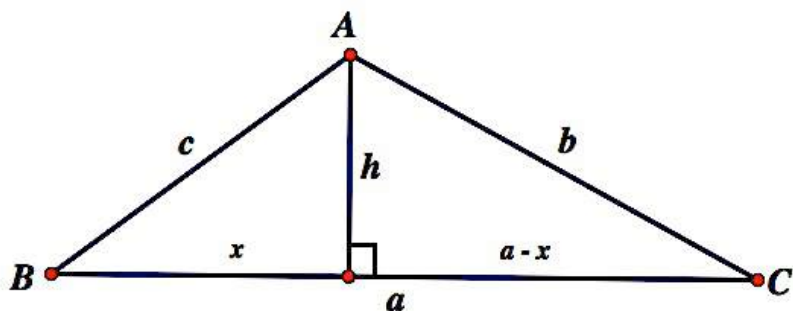

- Use this diagram to derive one of the forms of the Law of Cosines you wrote above. (Hint: As in the previous task, *More Than Right*, the length of the altitude can be represented in two different ways, both using the Pythagorean theorem and the portions of side  $a$  that form the legs of two different right triangles.)
- Use the same diagram above to derive the **Law of Sines**. (Hint: How can you represent the length of the altitude in two different ways using sides  $a$ ,  $b$ , or  $c$  and right triangle trigonometry instead of the Pythagorean theorem?)

## 5.7 Justifying the Laws – Teacher Notes

### *A Solidify Understanding Task*

**Purpose:** In this task students examine proofs of the Law of Cosines and the Law of Sines using the geometric and algebraic strategies developed in the previous task. Generic triangles in this task are labeled using the convention that the side opposite  $\angle A$  is labeled as side  $a$ , the side opposite  $\angle B$  is labeled as side  $b$ , and the side opposite  $\angle C$  is labeled as side  $c$ . Students examine how they can represent the length of a leg of a right triangle  $ABC$  with a trig expression in terms of a labeled angle and a labeled side (e.g., “ $b\cos(A)$ ”). Such expressions are used in the algebraic derivation of the Law of Cosines and Law of Sines. The next task will provide students with opportunities to practice these laws in applications, such as finding the area of a triangle.

**Note to teachers:** Since students have only worked with right triangle trigonometry, finding the sine or cosine of an angle measuring greater than 90 has no meaning, since such angles do not exist in right triangles. This task, and the RSG homework that accompanies this task, takes this restriction into account.

#### **Core Standards Focus:**

**G.SRT.10** (+) Prove the Laws of Sines and Cosines and use them to solve problems.

**G.SRT.11** (+) Understand and apply the Law of Sines and the Law of Cosines to find unknown measurements in right and non-right triangles (e.g., surveying problems, resultant forces).

#### **Standards for Mathematical Practice:**

**SMP 7 – Look for and make use of structure**

**The Teaching Cycle:****Launch (Whole Class):**

Students will need to understand how the diagram referred to in questions 1-6 was constructed so they can make sense of the algebraic work of these questions. If you have Geometer's Sketchpad or similar dynamic geometry software, you may want to have students construct this diagram using the software, or provide a pre-constructed version of the diagram for the students to use. If students are constructing this diagram for themselves, it will help to first create a custom "square" tool so the three squares on the sides of the triangle are easy to create. Whether or not you are using dynamic geometry software or the static diagram on the second page of the task, help students understand how the diagram was created: first, an acute triangle  $ABC$  was constructed using three arbitrary points as vertices; second, a square was constructed on each side of the triangle; third, the lines containing the three altitudes of the triangle were constructed—these lines dividing each square into two smaller rectangles.

Note for students: When we refer to  $\angle A$ ,  $\angle B$  or  $\angle C$  we are referring to the angles of the original triangle, even though the altitudes form additional angles at each vertex. Also, the triangle has been labeled in the standard way, with the side opposite  $\angle A$  labeled as side  $a$ , etc.

Model the algebraic work of question 1 by finding an expression for one of the six small rectangles. For example, if the segment highlighted in the following diagram has unknown length  $x$ , then  $\cos C = \frac{x}{a}$ , so  $x = a \cos C$ , and the area of the shaded rectangle is  $b \cdot a \cos C$ . Ask students to find similar ways to label all six rectangles, and then have them continue with questions 2-6.

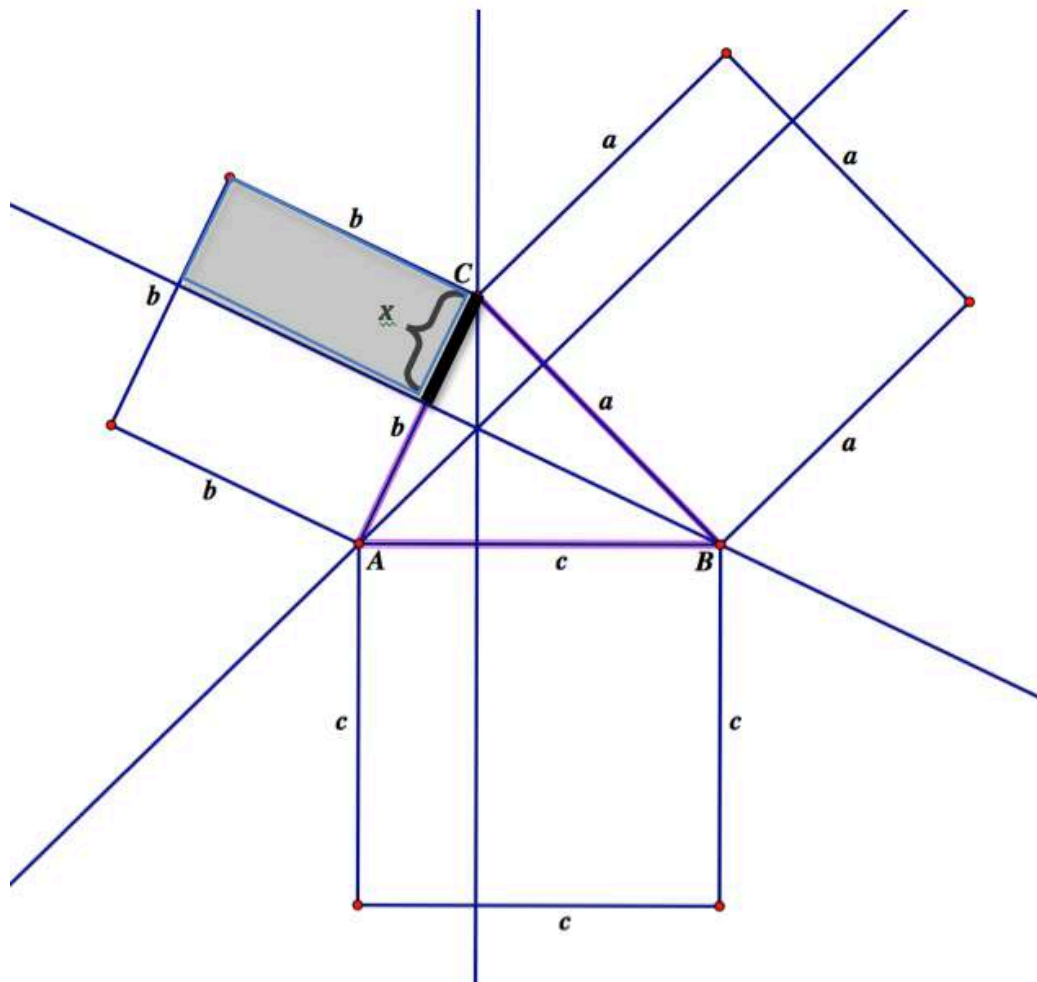

**Explore (Small Group):**

For question 2 students should end up with a colored diagram, similar to the following. (Note: Because students are choosing which color to use for each area expression, their diagrams may be colored differently from what is shown below; however, the same pairs of rectangles should share the same colors.)

Based on the color-coding of the diagram below, for question 3 students would write:

$$a^2 = \text{blue} + \text{red}$$

$$b^2 = \text{blue} + \text{green}$$

$$c^2 = \text{green} + \text{red}$$

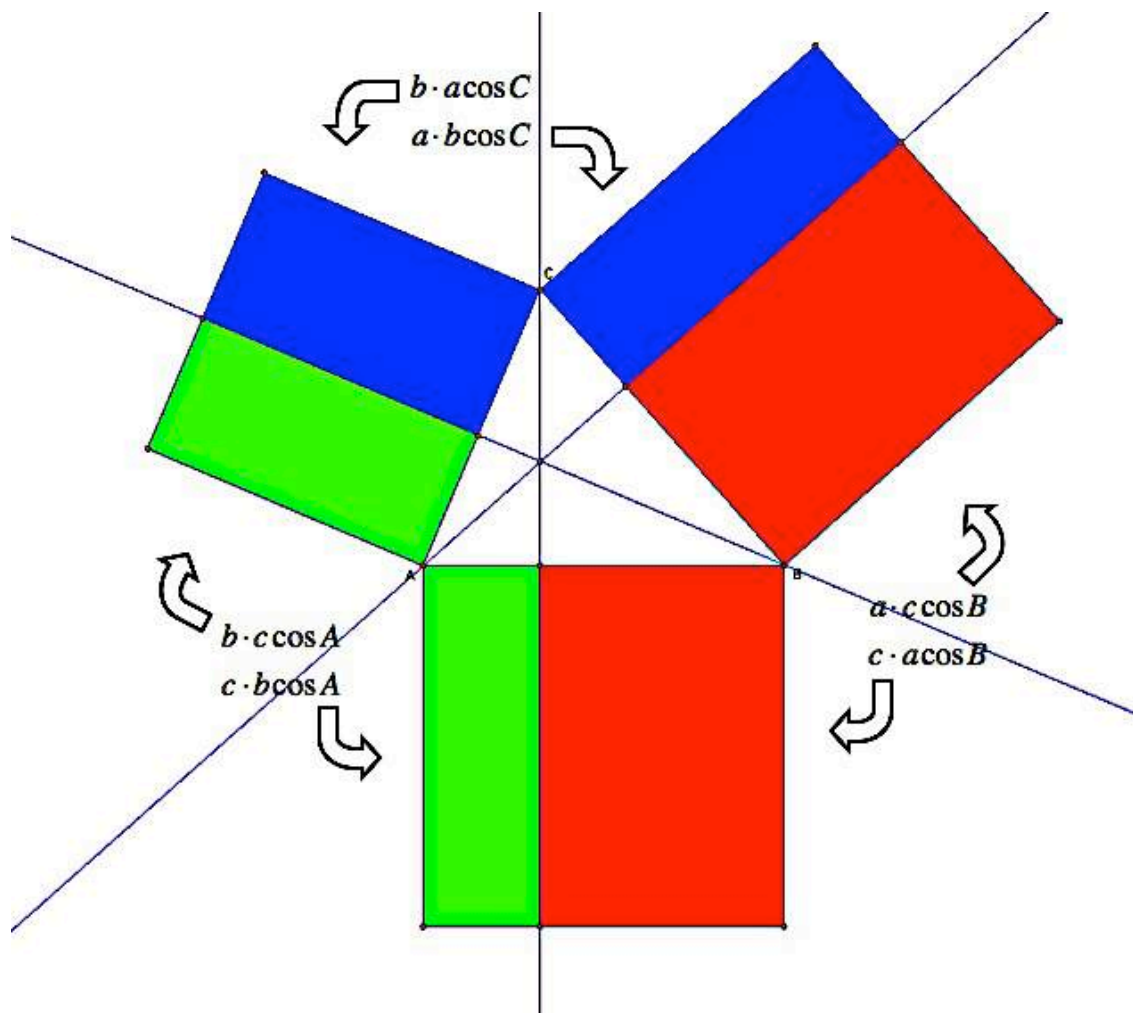

Using the diagram and the suggestions given in 4 and 5, students should be able to derive the three forms of the Law of Cosines:

$$a^2 = b^2 + c^2 - 2bc \cos A$$

$$b^2 = a^2 + c^2 - 2ac \cos B$$

$$c^2 = a^2 + b^2 - 2abc \cos C$$

Question 7 is intended to help students notice that the Pythagorean theorem is a special case of the Law of Cosines with right triangles. If  $\angle C$  is a right angle, then the legs are the altitudes, so the squares on the two legs do not get divided into smaller rectangles. Only the square on the hypotenuse will be



divided into two smaller rectangles by the altitude drawn from  $C$ . These two rectangles formed on the hypotenuse will be the same colors as the two squares on the other two sides. This is best illustrated by using a dynamic sketch of the diagram and dragging point  $C$  until it forms a right angle.

This derivation falls apart if one of the angles is obtuse. Therefore, question 9 asks students to derive the Law of Cosines in terms of a diagram that does work for obtuse triangles. This same diagram is used in question 10 to derive the Law of Sines.

For the Law of Cosines, students will need to use the decomposition of side  $a$  into two smaller segments of length  $x$  and  $a - x$ . They should ignore the labels on these two smaller segments when deriving the Law of Sines. (This will focus their attention on using the sine ratio rather than the cosine ratio. If students are using the cosine ratio for question 10, point out that in the Law of Cosines we used the cosine ratio, but the intent of the Law of Sines is to find a relationship between the sines of the angles. This derivation of the Law of Sines will involve the ratios  $\sin B$  and  $\sin C$ .)

### Discuss (Whole Class):

If needed, have a student present how they derived the Law of Cosines using the color-coded rectangles.

Focus the remainder of the discussion on deriving the Law of Cosines and the Law of Sines using the diagram given prior to question 9. Point out that this diagram works equally well for obtuse and acute triangles. If available, use student work to outline this proof. If necessary, prompt the work of the derivation by asking questions such as, "How could we determine the length of segment  $h$  in two different ways?"

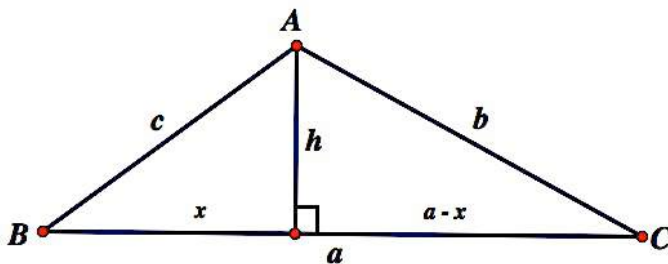

Derivation of the Law of Cosines based on this diagram:

$$x^2 + h^2 = c^2 \Rightarrow h^2 = c^2 - x^2$$

$$(a-x)^2 + h^2 = b^2 \Rightarrow h^2 = b^2 - (a-x)^2 = b^2 - (a^2 - 2ax + x^2) = b^2 - a^2 + 2ax - x^2$$

$$b^2 - a^2 + 2ax - x^2 = c^2 - x^2$$

$$b^2 = a^2 + c^2 - 2ax$$

$$\cos B = \frac{x}{c} \Rightarrow x = c \cos B$$

$$b^2 = a^2 + c^2 - 2ac \cos B$$

If you had to do a lot of prompting on the derivation of the Law of Cosines, give students a few extra minutes to work on deriving the Law of Sines for themselves, since it involves similar reasoning.

Derivation of the Law of Sines based on this diagram:

$$\sin B = \frac{h}{c} \Rightarrow h = c \sin B$$

$$\sin C = \frac{h}{b} \Rightarrow h = b \sin C$$

$$c \sin B = b \sin C$$

This last statement is equivalent to  $\frac{\sin B}{b} = \frac{\sin C}{c}$ , the more conventional form for writing the Law of Sines.

Point out to students that if  $\triangle ABC$  is acute we could use an altitude drawn from angle  $B$  or angle  $C$  to show that the ratio  $\frac{\sin A}{a}$  is also equivalent to  $\frac{\sin B}{b}$  or  $\frac{\sin C}{c}$ , leading to the more extended version of the Law of Sines,  $\frac{\sin A}{a} = \frac{\sin B}{b} = \frac{\sin C}{c}$ . (This can also be shown to be true for obtuse triangles, but it requires that students work with an altitude that lies outside of the triangle, and the use of a trig identity,  $\sin A = \sin (180^\circ - A)$ , which students do not yet have access to. See teacher note above.)

**Aligned Ready, Set, Go: Modeling with Geometry 5.7**

READY, SET, GO!

Name

Period

Date

**READY**

Topic: Recalling circumference and area of a circle

**Use the given information to find the indicated value. Leave  $\pi$  in your answer. Include the correct unit.**

1. radius = 3 ft

circumference:

area:

2. diameter = 14 cm

circumference:

area:

3. circumference =  $38\pi$  km

radius:

area:

4. area =  $49\pi$  in<sup>2</sup>

diameter:

circumference:

5. circumference =  $15\pi$  mi

radius:

area:

6. area =  $121\pi$  m<sup>2</sup>

radius:

circumference:

**Solve for the missing angle. Round your answers to the nearest degree.**

(Hint: In problems 10, 11, and 12, get the trig function alone. Then solve for  $\theta$ .)

7.  $\cos \theta = \frac{1}{6}$

8.  $\tan \theta = \frac{2}{3}$

9.  $\sin \theta = \frac{7}{8}$

10.  $5 \sin \theta - 2 = 0$

11.  $7 \cos \theta - 6 = 0$

12.  $4 \tan \theta - 1 = 0$

**SET**

Topic: Using the Laws of sine and cosine to solve triangles

<p><b>Law of Sines:</b> If <math>ABC</math> is a triangle with sides <math>a</math>, <math>b</math>, and <math>c</math>, then</p> $\frac{a}{\sin A} = \frac{b}{\sin B} = \frac{c}{\sin C}$ <p>or it can be written as:</p> $\frac{\sin A}{a} = \frac{\sin B}{b} = \frac{\sin C}{c}$	<p><b>Law of Cosines:</b> If <math>ABC</math> is a triangle with sides <math>a</math>, <math>b</math>, and <math>c</math>, then</p> $a^2 = b^2 + c^2 - 2bc \cos A$ $b^2 = a^2 + c^2 - 2ac \cos B$ $c^2 = a^2 + b^2 - 2ab \cos C$
---	--

Need help? Visit [www.rsgsupport.org](http://www.rsgsupport.org)

Use the *Law of sines* to solve each triangle.

13.

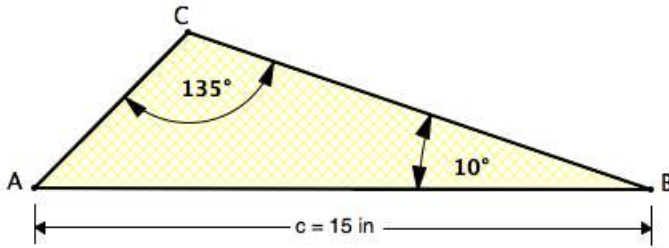

14.

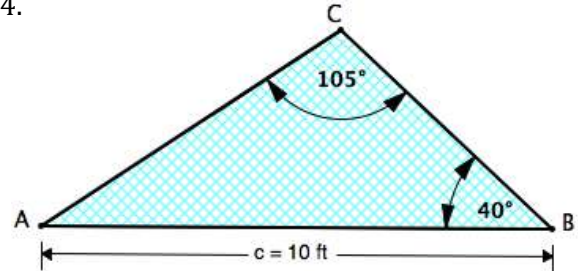

15.

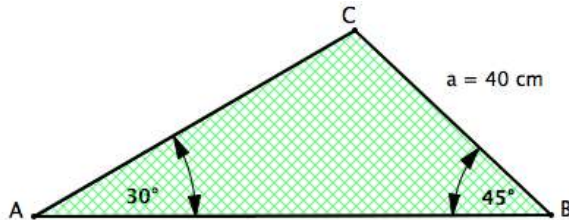

16.

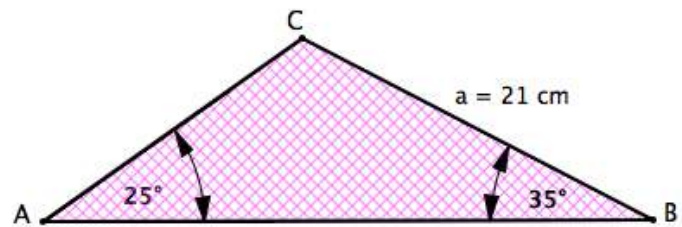

17. What information do you need in order to use the *Law of sines*?

18. Use the *Law of cosines* to find the remaining angles and side of the triangle.

19. Use the *Law of cosines* to find the remaining angles and side of the triangle.

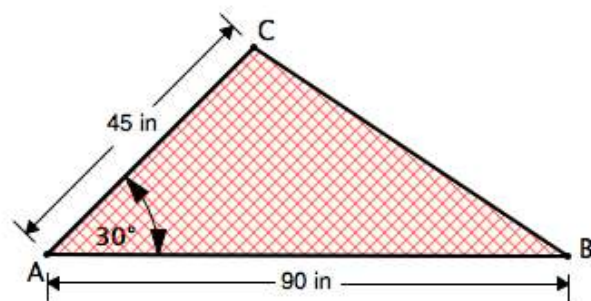
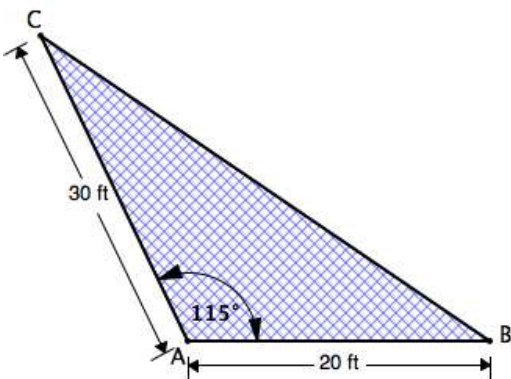

Need help? Visit [www.rsgsupport.org](http://www.rsgsupport.org)

20. Use the *Law of cosines* to find the three angles of the triangle.

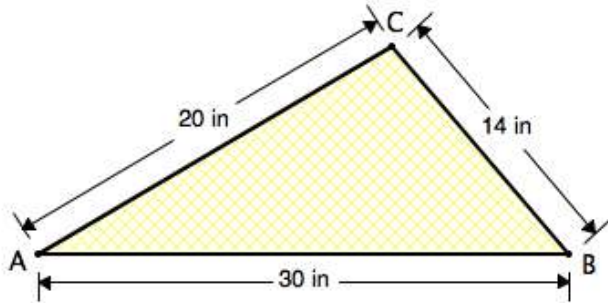

21. Use the *Law of cosines* to find the three angles of the triangle.

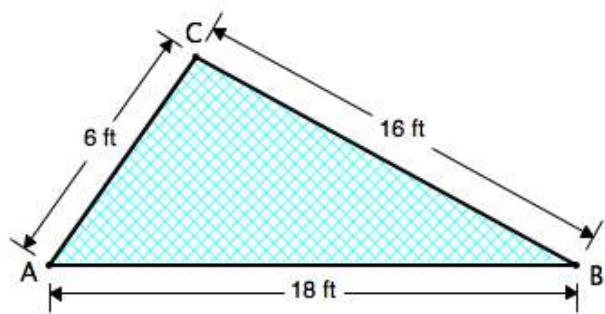

22. What information do you need in order to use the *Law of cosines* to solve a triangle?

**GO**

Topic: Recalling the trig ratios of the special right triangles

**Fill in the missing angle. Do NOT use a calculator.**

23. $\sin \theta = \frac{\sqrt{2}}{2}$	24. $\tan \theta = \sqrt{3}$	25. $\cos \theta = \frac{1}{2}$
26. $\sin \theta = \frac{\sqrt{3}}{2}$	27. $\tan \theta = 1$	28. $\tan \theta = \frac{\sqrt{3}}{3}$
29. $\sin \theta = \frac{1}{2}$	30. $\cos \theta = \frac{\sqrt{2}}{2}$	31. $\cos \theta = \frac{\sqrt{3}}{2}$

Need help? Visit [www.rsgsupport.org](http://www.rsgsupport.org)

## 5.8 Triangle Areas by Trig

### A Practice Understanding Task

Find the area of the following two triangles using the strategies and procedures you have developed in the past few tasks. For example, draw an altitude as an auxiliary line, use right triangle trigonometry, use the Pythagorean theorem, or use the Law of Sines or the Law of Cosines to find needed information.



CC BY Shelly  
<https://flic.kr/p/uuVVs5>

1. Find the area of this triangle.

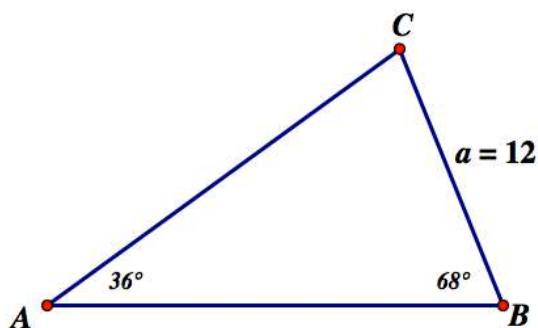

2. Find the area of this triangle.

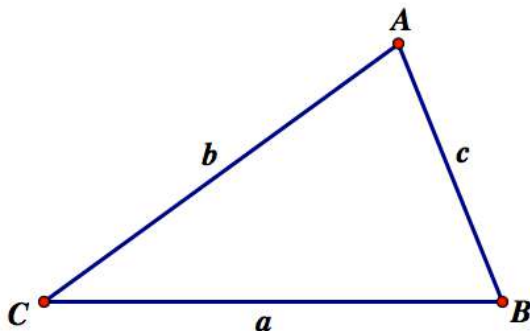

Jumal and Jabari are helping Jumal's father with a construction project. He needs to build a triangular frame as a component of the project, but he has not been given all the information he needs to cut and assemble the pieces of the frame. He is even having a hard time envisioning the shape of the triangle from the information he has been given.

Here is the information about the triangle that Jumal's father has been given.

- Side  $a = 10.00$  meters
- Side  $b = 15.00$  meters
- Angle  $A = 40.0^\circ$

Jumal's father has asked Jumal and Jabari to help him find the measure of the other two angles and the missing side of this triangle.

Carry out each student's strategy as described below. Then draw a diagram showing the shape and dimensions of the triangle that Jumal's father should construct. (Note: To provide as accurate information as possible, Jumal and Jarbari decide to round all calculated sides to the nearest cm—that is, to the nearest hundredth of a meter—and all angle measures to the nearest tenth of a degree.)

#### Jumal's Approach

- Find the measure of angle  $B$  using the Law of Sines
- Find the measure of the third angle  $C$
- Find the measure of side  $c$  using the Law of Sines
- Draw the triangle

Jabari's Approach

- Solve for  $c$  using the Law of Cosines:  $a^2 = b^2 + c^2 - 2bc \cos(C)$

(Jabari is surprised that this approach leads to a quadratic equation, which he solves with the quadratic formula. He is even more surprised when he finds two reasonable solutions for the length of side  $c$ .)

- Draw both possible triangles and find the two missing angles of each using the Law of Sines



## 5.8 Triangle Areas by Trig – Teacher Notes

### *A Practice Understanding Task*

**Purpose:** The purpose of this task is to practice the strategies that have been used in the previous tasks for finding missing sides and angles of non-right triangles. These strategies include drawing an altitude of a triangle as an auxiliary line, using right triangle trigonometry to label sides of the right triangles formed by the altitude, using the Pythagorean theorem to relate sides of the right triangles formed by the altitude, or choosing to use the Law of Sines or the Law of Cosines as appropriate for the given information. Problem 2 leads to an alternative formula for the area of a triangle:  $A = \frac{1}{2} ab \sin(C)$ . Problem 3 introduces the ambiguous case of the Law of Sines.

#### **Core Standards Focus:**

**G.SRT.9 (+)** Derive the formula  $A = \frac{1}{2} ab \sin(C)$  for the area of a triangle by drawing an auxiliary line from a vertex perpendicular to the opposite side.

**G.SRT.10 (+)** Prove the Laws of Sines and Cosines and use them to solve problems.

**G.SRT.11 (+)** Understand and apply the Law of Sines and the Law of Cosines to find unknown measurements in right and non-right triangles (e.g., surveying problems, resultant forces).

#### **Standards for Mathematical Practice:**

**SMP 7 – Look for and make use of structure**

**SMP 8 – Look for and express regularities in repeated reasoning**

#### **The Teaching Cycle:**

##### **Launch (Whole Class):**

Remind students of the strategies they have used in the previous tasks to find missing sides and angles in non-right triangles as described in the introductory paragraph of this task. Students should be able to go right to work on this task following this brief introduction.

**Explore (Small Group):**

Problem 1 is intended to set up the mathematical thinking that will be used in problem 2 to derive an alternative formula for the area of a triangle based on the length of two sides and an included angle. Students should begin with their familiar formula for finding the area of a triangle,  $A = \frac{1}{2}bh$ . In problem 1, students can use the Law of Sines to find the lengths of the missing sides of the triangle—one of which can be treated as the base. They will also need to find the length of the altitude associated with this base using a trig ratio. They can then apply their known area formula to find the area of the triangle.

Problem 2 follows the same pattern as problem 1, only the length of the base and corresponding altitude will be a variable and an expression. It is assumed that most students will use side  $a$  as the base, but the corresponding altitude could be written as  $h = b\sin C$  or  $h = c\sin B$ , leading to two different expressions for the area. Watch for both expressions to emerge.

Problem 3 introduces the ambiguous case of the Law of Sines. Jumal’s approach leads to a unique triangle, whereas Jabari’s approach leads to two triangles that satisfy the given conditions. Here is an example as to why  $SSA$  cannot be guaranteed to give us congruent triangles. Identify students who can present both approaches (see notes below).

**Discuss (Whole Class):**

Only have a presentation on problem 1 if there are students who have not successfully found the area of that triangle. Rather, begin by have two students present their work on problem 2—one who got  $A = \frac{1}{2}ab\sin C$  and one who got  $A = \frac{1}{2}ac\sin B$  for the area formula. Note that for this *labeled* triangle, both formulas are correct. More important than memorizing either formula is to recognize what information is used in each case to determine the area of the triangle. Ask students what an area “rule” might be for an *unlabeled* triangle. Students should recognize that in each case we are taking *one-half of the product of the length of two sides and the sine of the included angle*.

For question 3, begin by having a student draw a diagram that would represent the given information, such as the diagram below. (Note that this is a SSA situation.) Then have one student present Jumal's approach, and one student present Jabari's.

Jumal's approach:

- Find the measure of angle  $B$  using the Law of Sines:

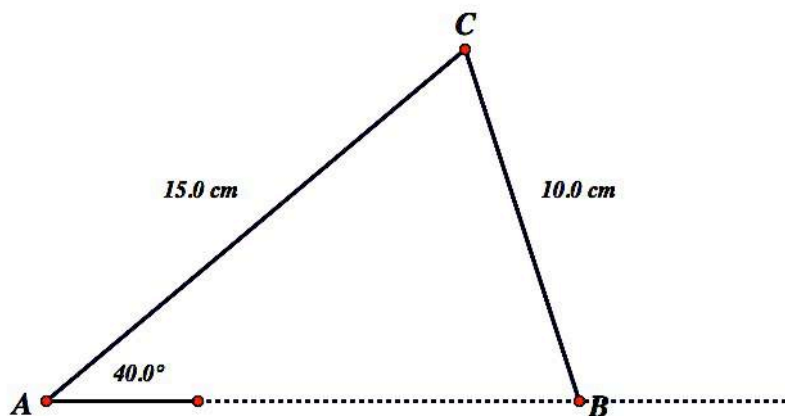

$$\frac{\sin 40^\circ}{10} = \frac{\sin B}{15} \Rightarrow \frac{15 \sin 40^\circ}{10} = \sin B \Rightarrow \sin^{-1}\left(\frac{15}{10} \sin 40^\circ\right) = B = 74.6^\circ$$

- Find the measure of the third angle  $C$ :

$$180^\circ - 40^\circ - 74.6^\circ = 65.4^\circ$$

- Find the measure of side  $c$  using the Law of Sines:

$$\frac{\sin 65.4^\circ}{c} = \frac{\sin 40^\circ}{10} \Rightarrow c = \frac{10 \sin 65.4^\circ}{\sin 40^\circ} \approx 14.14 \text{ cm}$$

- Draw the triangle:

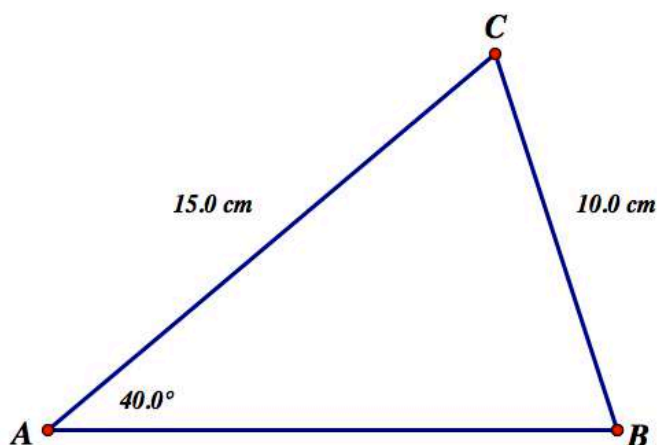

### Jabari's Approach

- Solve for  $c$  using the Law of Cosines:  $a^2 = b^2 + c^2 - 2bc \cos(C)$

$$10^2 = 15^2 + c^2 - 2(15)(c)(\cos 40^\circ)$$

$$\cos 40^\circ = 0.766$$

$$100 = 225 + c^2 - 22.98c$$

[Use the quadratic formula to solve for  $c$ ]

$$0 = c^2 - 22.98c + 125$$

$$\frac{22.98 \pm \sqrt{22.98^2 - 4 \cdot 1 \cdot 125}}{2 \cdot 1} \approx 14.14 \text{ cm} \quad \text{or} \quad 8.84 \text{ cm}$$

- Draw both possible triangles and find the two missing angles of each using the Law of Sines

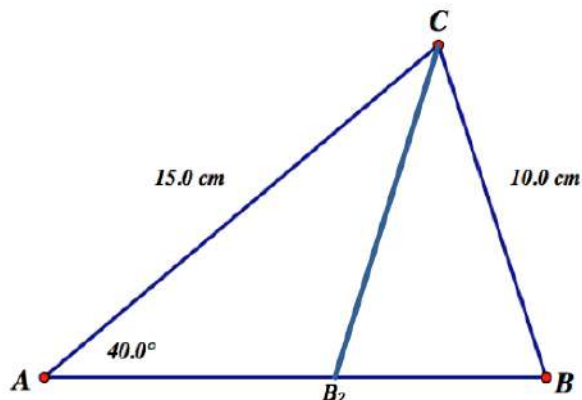

$$\frac{\sin 40^\circ}{10} = \frac{\sin C}{8.84} \Rightarrow C = \sin^{-1}\left(\frac{8.84 \sin 40^\circ}{10}\right) = 34.6^\circ$$

$$B_2 = 180^\circ - 40^\circ - 34.6^\circ = 105.4^\circ$$

It might be helpful for students to think of side  $CB$  as being free to “swing” around a circle, as in the following diagram. Note that there are two points of intersection between the collection of possible radii of the circle and the line that contains side  $AB$  of the triangle. Consequently, two triangles can be defined using the same  $SSA$  criteria.

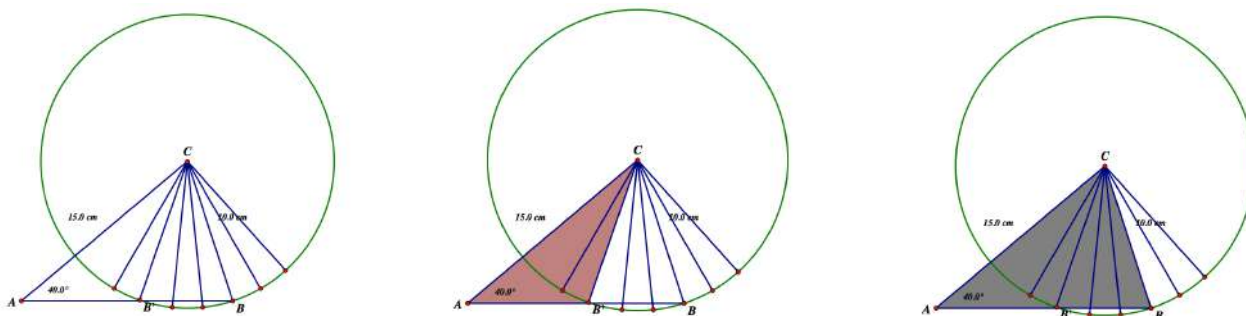

**Aligned Ready, Set, Go: Modeling with Geometry 5.8**

READY, SET, GO!

	Name	Period	Date
--	------	--------	------

**READY**

Topic: Rotational symmetry

Hubcaps have *rotational symmetry*. That means that a hubcap does not have to turn a full circle to appear the same. For instance, a hubcap with this pattern,  will look the same every 1/4 turn. It is said to have 90° *rotational symmetry* because for each quarter turn it rotates 90°.

**State the rotational symmetry for the following hubcaps. Focus your answer on just the spokes, not the center design.** (Answers will be in degrees.)

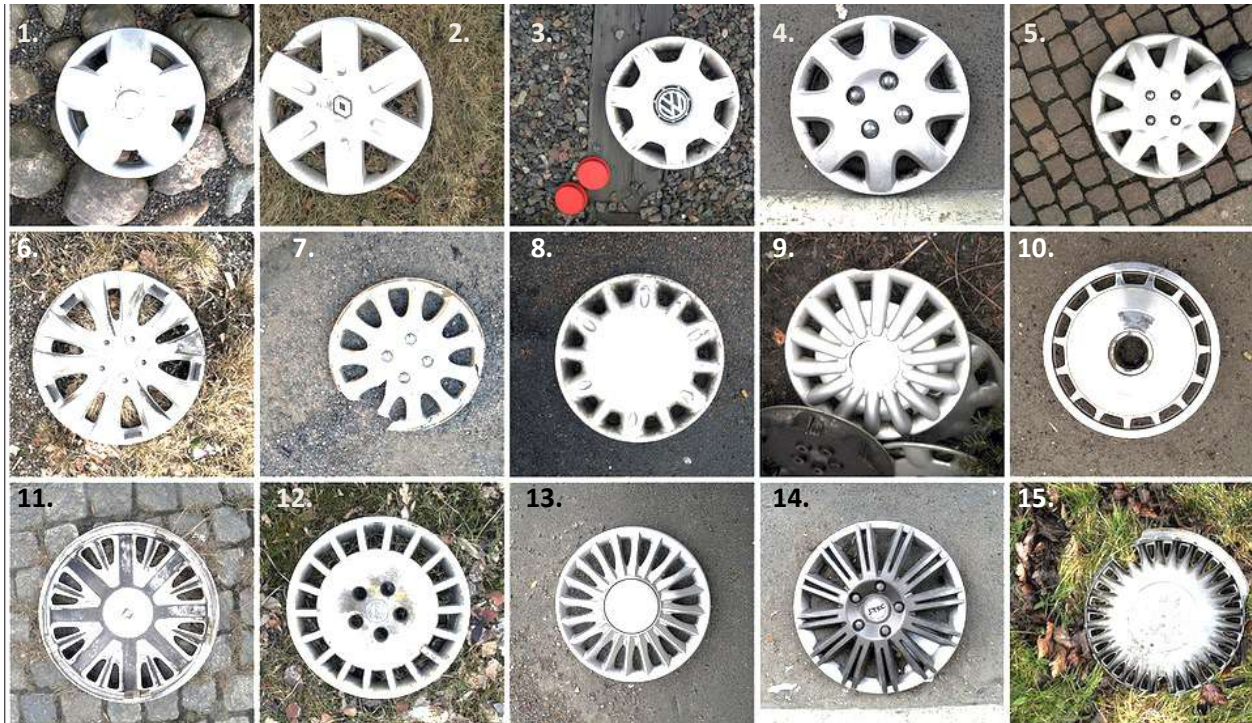

**SET**

Topic: Area formulas for triangles

*Area of an Oblique Triangle:* The area of **any** triangle is one-half the product of the lengths of two sides times the sine of their included angle.  $Area = \frac{1}{2}bc \sin A = \frac{1}{2}ab \sin C = \frac{1}{2}ab \sin B$

**Need help?** Visit [www.rsgsupport.org](http://www.rsgsupport.org)



Find the area of the triangle having the indicated sides and angle.

16.  $C = 84.5^\circ$ ,  $a = 32$ ,  $b = 40$

17.  $A = 29^\circ$ ,  $b = 49$ ,  $c = 50$

18.  $B = 72.5^\circ$ ,  $a = 105$ ,  $c = 64$

19.  $C = 31^\circ$ ,  $a = 15$ ,  $b = 14$

20.  $A = 42^\circ$ ,  $b = 25$ ,  $c = 12$

21.  $B = 85^\circ$ ,  $a = 15$ ,  $c = 12$

Another formula for the area of a triangle can be derived from the *Law of Sines*.

$$\text{Area} = \frac{c^2 \sin A \sin B}{2 \sin C}$$

Use this formula to find the area of the triangles.

22.

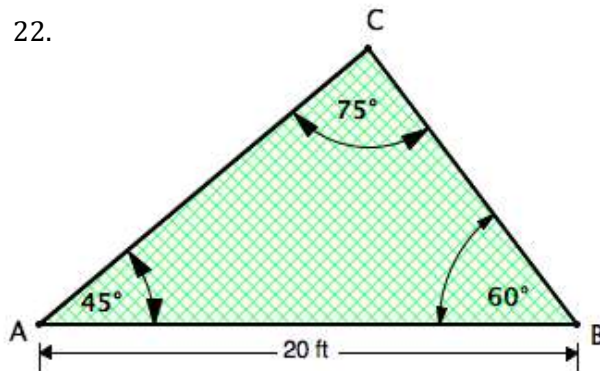

23.

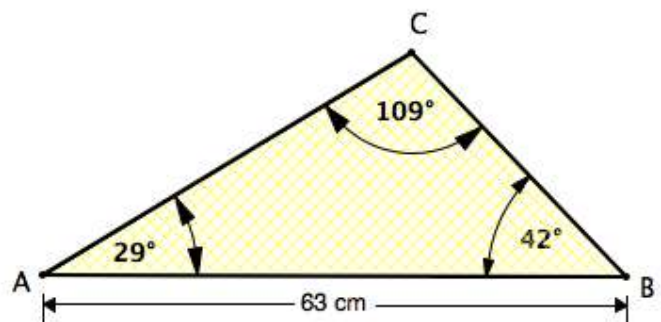

Perhaps you used the *Law of Cosines* to establish the following formula for the area of a triangle. The formula was known as early as circa 100 B.C. and is attributed to the Greek mathematician, Heron.

*Heron's Area Formula:* Given any triangle with sides of lengths  $a$ ,  $b$ , and  $c$ , the area of the triangle is:

$$\text{Area} = \sqrt{s(s-a)(s-b)(s-c)} \text{ where } s = \frac{(a+b+c)}{2}.$$

Need help? Visit [www.rsgsupport.org](http://www.rsgsupport.org)

Find the area of the triangle having the indicated sides.

24.  $a = 11, b = 14, c = 20$

25.  $a = 12, b = 5, c = 9$

26.  $a = 12.32, b = 8.46, c = 15.05$

27.  $a = 5, b = 7, c = 10$

GO

Topic: Distinguishing between the *law of sines* and the *law of cosines*

Indicate whether you would use the *Law of Sines* or the *Law of Cosines* to solve the triangles. Do not solve.

28.

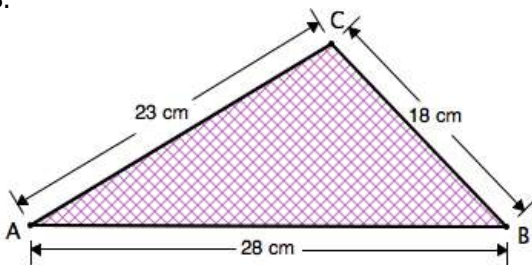

29.

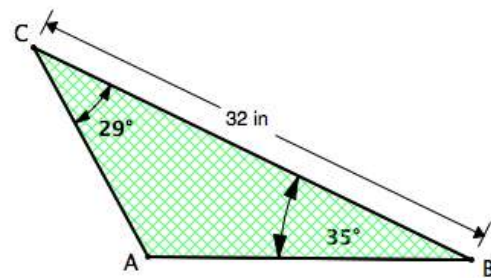

30.

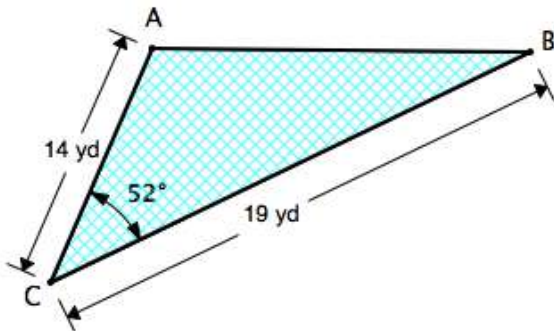

31.

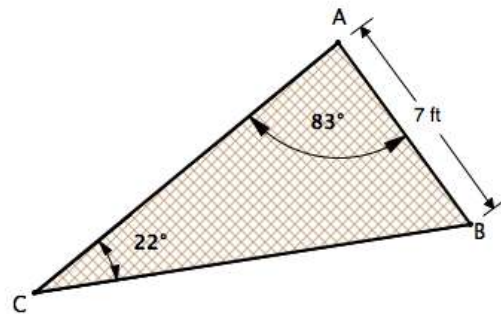

Need help? Visit [www.rsgsupport.org](http://www.rsgsupport.org)



This book is shared online by Free Kids Books at <https://www.freekidsbooks.org> in terms of the creative commons license provided by the publisher or author.

Want to find more books like this?



<https://www.freekidsbooks.org>

Simply great free books -

Preschool, early grades, picture books, learning to read,  
early chapter books, middle grade, young adult,

Pratham, Book Dash, Mustardseed, Open Equal Free, and many more!

*Always Free – Always will be!*

**Legal Note:** This book is in CREATIVE COMMONS - Awesome!! That means you can share, reuse it, and in some cases republish it, but only in accordance with the terms of the applicable license (not all CCs are equal!), attribution must be provided, and any resulting work must be released in the same manner.

Please reach out and contact us if you want more information:

<https://www.freekidsbooks.org/about> Image Attribution: Annika Brandow, from You! Yes You! CC-BY-SA. This page is added for identification.